



Capacity for Rail

***Towards an affordable, resilient, innovative  
and high-capacity European Railway  
System for 2030/2050***

Upgrading of infrastructure in  
order to meet new operation  
and market demands (Final)

Submission date: 01/09/2017

Public deliverable D 11.5

*This project has received funding  
from the European Union's  
Seventh Framework Programme  
for research, technological  
development and demonstration  
under grant agreement n° 605650*



Collaborative project SCP3-GA-2013-60560  
Increased Capacity 4 Rail networks through  
enhanced infrastructure and optimised operations  
FP7-SST-2013-RTD-1

## Lead contractor for this deliverable:

---

- Trafikverket

## Project coordinator

---

- International Union of Railways, UIC

[www.Capacity4rail@eu](http://www.Capacity4rail@eu)

## Executive Summary

Upgrading of existing lines to enhanced freight capacity is one of the most important questions to promote railway freight and meet future demands from industry and society.

The reason is that today very few railway lines worldwide are constructed specifically for freight traffic. The current trend is instead that new lines are constructed for high-speed operations, whereas remaining lines are transformed towards more freight and regional traffic. These existing lines were however built for the traffic demands at the time of construction, which may be very different from the traffic situations for which they are to be used.

This means that lines need to be upgraded in order to meet the new demands from increased freight operations that often have a different character than the freight traffic that existed before the transition. In this context it should be noted that freight operators often propose enhanced operations (e.g. longer trains, increased axle loads, more frequent operations), which commonly are not realised due to infrastructure limitations. The way around this is to upgrade the lines. The experience from countries that have allowed enhanced operations through upgrading is that there are indeed limitations to what can be utilized, but also possibilities to overcome and/or circumvent these limitations. To achieve this, it is important that the upgrading is carried out in a systematic manner with a clear vision of the desired transport concept, and that state-of-the-art knowledge is employed.

Several Research & Development projects during the last 20 years have increased the knowledge and understanding, and introduced tools to handle upgrading. This has enabled demands from freight operators to be met in a more environmentally friendly and more cost-efficient manner than what was previously possible. An overview of some projects that provides this input is presented in Figure E.1.

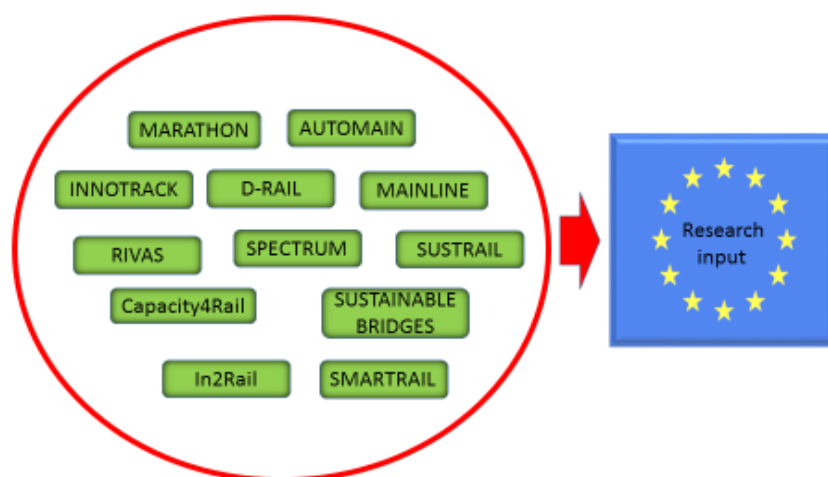

FIGURE E.1. EXAMPLE OF EU-PROJECTS THAT HAVE PROVIDED KNOWLEDGE TO THIS GUIDELINE

Despite the increasing need for freight line upgrading, and the increased knowledge on means and methods to carry out such an upgrading, there has until now not existed any extensive guideline or

best praxis compilation founded on recent research and development. This report in the Capacity4Rail project—“Upgrading of infrastructure in order to meet new operation and market demands”—aims to fill this need.

The target audience for this work includes infrastructure managers, contractors and regulatory bodies. In addition, the text is heavily referenced to allow for in-depth investigations of track, structure experts and researchers.

The report sets of by an introduction where background and objectives to the report are presented. Here, also the issue on how different traffic situations generate different demands is tackled.

After this introduction, the chapter on substructure sets out by proposing a working method for ensuring sufficient substructure capabilities when upgrading railway operations. This sets out with an overview on methods for assessing substructure conditions, followed by an overview of methods to assess substructure quality and on innovative methods for improving substructure performance. Finally, mitigation of ground vibrations, which is an essential issue especially in urban areas, is described.

The chapter about bridges starts with how new traffic situations influences upgrading. Then differences are discussed on safety concepts in codes for new and existing structures. Many uncertainties are present when a new structure is built and they call for a high safety factor. Instead, when we are dealing with an existing structure, actual loads, geometries and material properties (including deterioration rates) can be determined with a high accuracy. Therefore safety factors can in some cases be reduced for existing structures

Working methods for assessment of existing bridges are presented and a recommended way to work in three phases is introduced: Initial, Intermediate and Enhanced. The Initial phase includes a site visit, study of documentation and an overview calculation. The Intermediate phase may include material investigations, detailed calculations and/or analyses, and also additional inspections and monitoring. The Enhanced phase usually consists of refined calculations and analyses including statistical modelling and reliability based assessments, laboratory examinations and/or field-testing and economic decision analyses. A thorough assessment, as outlined above, is often the most cost effective way to upgrade a structure. This is exemplified by cases where a high hidden capacity was confirmed by such an assessment and by full-scale tests.

For tunnels, different cross sections and typical loading gauges are discussed as these will have a major influence on the operational capabilities. Further, possibilities for working in tunnels with rail service in operation, which will significantly decrease operational disruptions, are discussed. Examples are provided on variations in conditions in countries such as Germany, Austria, Switzerland, Sweden and the U.S.

For culverts, different types of damage and malfunction are described and examples are given on suitable measures. Examples are also given on how retaining walls can be upgraded.

The following chapter dealing with track and switches & crossings presents a method for upgrading that consists of two levels of successively refined analyses. The first level consists of experienced-based models which employ historical and empirical data. If the upgrading is not too extensive, such an analysis provides a good overview that can be used to take a first decision and also to make priorities in the next step which consists of prediction-based analyses. These analyses employ numerical simulations to make detailed assessments of the consequences of upgrading.

To set these approaches in context, the chapter includes an overview of different deterioration phenomena, and descriptions of potential consequences of different types of upgrading. The chapter also describes maintenance routines that can reduce costs and traffic disturbances after upgrading. This includes proactive approaches such as selection of suitable rail and wheel grades, and establishment of maintenance strategies. It also includes operational maintenance regimes such as grinding, lubrication and welding, and topics such as automation of maintenance.

Some topics related to upgrading, such as energy supply, signalling and stations are very dependent on local and existing conditions. Further, upgrading of energy and signalling is currently mainly carried out for passenger traffic. In this context upgrading strategies are relatively well known and depend highly on the system used. As for stations, suitable means to adjust these to an upgraded traffic situation are highly dependent on specific local situations. For these reasons, these topics are only be described in general terms.

The report also discusses the possibility of employing novel track forms that have been developed in other parts of the Capacity4 Rail.

Finally, the most important conclusions and recommendations are presented in a final chapter.

---

## Table of contents

---

Executive Summary .....	3
Table of contents .....	6
Abbreviations and acronyms.....	10
1. Background .....	12
1.1 Freight system parameters.....	13
1.2 Passenger system parameters.....	13
2. Objectives.....	17
2.1 How market requirements affect train, vehicles and infrastructure performance.....	18
2.2 The need for a system approach .....	18
3. Infrastructure – general topics.....	20
3.1 Introduction.....	20
3.2 Different traffic demands and operational enhancements .....	21
4. Substructure.....	23
4.1 Assessing substructure conditions .....	23
4.1.1 Overall assessment of substructure conditions .....	25
4.1.2 Methods for subgrade quality assessment .....	29
4.2 Subgrade improvements .....	51
4.2.1 Introduction .....	51
4.2.2 Overview of strengthening methods.....	52
4.2.3 Subgrade improvement methods .....	55
4.2.4 Other methods for subgrade improvement in railway infrastructure .....	67
4.2.5 Comparison of improvement methods .....	71
4.3 Mitigating ground vibrations .....	77
4.3.1 Methodology.....	77
4.3.2 Generation of vibrations .....	77
4.3.3 Track-based mitigation.....	78
4.3.4 Transmission reductions .....	79
5. Bridges.....	80
5.1 General .....	80
5.1.1. Codes for new and existing bridges – safety requirements .....	80

---

5.1.2. Influence of new traffic situations .....	81
5.1.3. Influence on maintenance routines .....	82
5.2 Work process – Assessment and strengthening of existing bridges.....	82
5.3 Foundations .....	84
5.4 Metallic bridges .....	86
5.4.1 Metallic truss bridge.....	86
5.4.2 Metallic beam bridges.....	87
5.4.3 Other metallic bridges.....	87
5.5 Masonry bridges .....	88
5.6 Concrete bridges.....	89
5.6.1 Bridges with T-beams .....	89
5.6.2 Trough bridges .....	90
5.6.3 Box girder bridges .....	91
5.6.4 Concrete arch bridges .....	92
5.6.5 Prestressed concrete bridges .....	93
5.6.6 Composite bridges.....	94
5.6.7 Concrete structural components .....	95
5.6.8 Summary of Methods for concrete bridges .....	96
5.7 Examples of assessment, strengthening and testing of bridges.....	96
5.7.1 Steel truss bridges .....	97
5.7.2 Concrete trough bridges .....	99
5.7.3 Prestressed bridges .....	103
5.8 References .....	105
6. Tunnels.....	118
6.1 General aspects .....	118
6.2 Work process.....	121
6.2.1 Assessment of tunnels .....	121
6.2.2 Extension of lined tunnels.....	122
6.3 Conditions and examples from different countries.....	126
6.3.1 Germany.....	126
6.3.2 Austria .....	127
6.3.3 Switzerland.....	128

---

6.3.4	Sweden.....	128
6.3.5	USA.....	130
6.4	References.....	130
7.	Culverts.....	133
7.1	General aspects.....	133
7.2	Work process.....	133
7.2.1	Current Situation.....	133
7.2.2	. Damage and malfunction.....	135
7.3	Examples.....	135
7.4	References.....	137
8.	Retaining walls.....	138
8.1	General.....	138
8.2	Work process.....	138
8.3	Examples.....	138
8.4	References.....	141
9.	Track and Switches & crossings.....	142
9.1	Preliminaries.....	142
9.1.1	Scope of the chapter.....	142
9.1.2	A brief overview of track deterioration.....	144
9.1.3	Influence of higher loading on deterioration.....	146
9.1.4	Evaluating of the effects of upgrading.....	150
9.1.5	Mitigating actions.....	150
9.1.6	References.....	152
9.2	Experience based methods.....	153
9.2.1	Overall estimation models.....	154
9.2.2	Component deterioration models.....	156
9.2.3	References.....	162
9.3	Prediction based methods.....	163
9.3.1	Consequences of heavier and/or faster operations.....	164
9.3.2	Consequences of longer trains.....	177
9.3.3	Consequences of increased operational frequency.....	179
9.3.4	Consequences of increased load gauge.....	179



---

9.3.5	References.....	181
9.4	Management of upgraded tracks .....	185
9.4.1	Proactive maintenance planning.....	185
9.4.2	Efficient maintenance .....	189
9.4.3	Development in maintenance procedures.....	195
9.5	References.....	197
10.	Energy supply .....	201
11.	Signalling .....	202
12.	Stations.....	203
13.	New upgrading concepts for superstructures.....	204
14.	Conclusions .....	206

---

## Abbreviations and acronyms

---

<b>Abbreviation / Acronyms</b>	<b>Description</b>
BCM	Business Centred Maintenance
CARS	China Academy of Railway Sciences
CFRP	Carbon Fibre Reinforced Polymer
CMP	Common Mid-Point
CRP	Combined Resistivity and Reflection
ERTMS	European Rail Traffic Management System
FM	Friction Modifiers
GHG	Green House Gases
GPR	Ground Penetrating Radar
GPS	Global Positioning System
HSL	High Speed Line
HSG	High Speed Grinding
IM	Infrastructure Manager
IST	Instituto Superior Técnico (University of Lisbon)
KTH	Royal Institute of Technology in Stockholm
MBC	Mineral Based Composite
RCF	Rolling Contact Fatigue
RBCM	Risk Based Centred Maintenance
RFC	Rail Freight Corridor
RFC	Ride Force Counter
RSMV	Rolling Stiffness Measurement Vehicle
RU	Railway Undertaking
SAFT	Synthetic Aperture Focus Technology
SoS	System of System

SRP	Symmetric Resistivity Profiling
TLV	Track Loading Vehicle
TOP	Top of Rail
TPG	Two Pass Grinding
TTCI	Transportation Technology Center, Inc
UBS	Under Ballast Mats
UIC	International railway union
USP	Under Sleeper Pads
WARR	Wide Angel Refraction and Reflection
VDM	Value Driven Maintenance
VUC	Variable Usage Change

## 1. Background

---

This deliverable, D11.5, is largely based on D11.4, but is heavily edited and supplemented with additional material on different topics, e.g. ballast and vibration. This also relates to results from other parts of C4R. For example, chapter 3 Traffic situation in D11.4 is now included in relevant chapters in D11.5. In this integration, also influences from the work in Capacity4Rail's SP2 "New concepts for freight" was included. Another example is chapter 13 "New upgrading concepts for superstructures" where it is discussed how innovative concepts developed in SP1 may be used when upgrading. The report also has a revised structure that makes it more feasible as a guideline and thereby promotes use and implementation.

Development of railways has always raised new demands. Speeds and loads have increased quite significantly during the history of the railways. For newly constructed lines, this has led to the introduction of larger rail profiles with better steel grades, improved rail support in the form of high-performing fastenings, sleepers and ballast layers, and in bridges designed for higher loads and speeds. At the same time, the large majority of the railway infrastructure is old and built according to codes and demands of the time of their construction.

Very few new railway lines are designed and constructed specifically for freight traffic. The trend today is instead that the new lines are designed for high-speed operations, whereas existing lines are transformed to carry more freight traffic. As mentioned, these existing lines are constructed for traffic demands from the time when they were built. This means that these lines have to be upgraded if they should fulfil the requirements of the new freight operations. Consequently, upgrading has and will be an important future measure to meet current and future demands on freight operations from industry and society.

The big challenge is (and has for a long time been) how to upgrade the existing infrastructure in a (cost) efficient, safe and environmentally friendly manner. To this end, the current deliverable aims to support Infrastructure Managers (IMs) in providing a methodical approach to assess their infrastructure with respect to upgraded freight traffic, to investigate the efficiency of different upgrading solutions, to carry out the upgrading and to maintain the upgraded infrastructure.

Several recent R&D projects have increased knowledge and understanding of infrastructure upgrading. Figure E1 in the Executive Summary shows examples of EU-projects carried out during the last 20 years that have provided input to this guideline.

The guideline is structured such that it sets out with chapters that describe the overall aims of the report and investigate the influence of different traffic situations.

In chapters 4 to 12 the influences of upgrading on different parts of the infrastructure are then described and investigated. Recommendations and examples of methods for assessment and analysis of upgrading consequences are provided.

Further, different maintenance related procedures are discussed in chapter 9 that focuses on track and switches & crossings.

## 1.1 FREIGHT SYSTEM PARAMETERS

For the customer, also the quality in terms of time for delivery, reliability, prevention of damage of goods etc. is important. In addition to quality, the cost of freight transports (in a broad sense) is the most important parameter to consider. A number of train and infrastructure parameters affects the cost. These are the axle load, the load per unit length, the loading gauge, the train weight and the train length. Here, the allowed axle load and the wagonload per meter are depending on the infrastructure standard where the condition of the entire track including substructure and bridges etc. is important. The train weight is also limited by the tractive effort of locomotives, the couplings and the electrical power supply.

The axle load often decides how much goods that can be carried in one wagon. The maximum axle load is therefore a good measure of the development of the railway systems, see figure 1.1. In the 19<sup>th</sup> century the highest allowed axle load was in the order of 10–15 tonnes, which in the 20<sup>th</sup> century increased to 20–25 tonnes. Today 22.5 tonnes is basically the standard in Europe. With 22.5 tonnes axle load, the gross weight of a 4-axle wagon can be  $4 \times 22.5 = 90$  tonnes. If the wagon tare weight is 25 tonnes the payload will be 65 tonnes. In the US it is common with 35.7 tonnes axle load which allows a payload of 120 tonnes on a 4-axle wagon.

Since the cost for wagon and train operations will increase only marginally with a higher axle load (and weight) the transportation cost will be lower the higher the allowed axle load. This line of reasoning is valid for heavy goods.

For bulky goods, instead the loading gauge in terms of the wagons maximal height, width and shape can be the critical parameter. Regardless of whether the axle load or the loading gauge limits the capacity, a much cost-efficient way of increasing capacity is to aim for “more freight in the wagon and more wagons in the train”.

However higher axle loads, higher load per unit length and a larger loading gauge, also mean requirements for better infrastructure, which can be costly. However, in situations where the track has been improved gradually and running characteristics of locomotives and wagons has improved, it has been possible to incrementally increase axle loads and speeds for freight trains – sometimes without any other measures than that the system has been continuously renewed and improved.

## 1.2 PASSENGER SYSTEM PARAMETERS

Although the focus of the guideline is on freight transport, it is important also to study the needs of passenger transports, not the least since most freight transports are carried out on lines where there are additional passenger operations.

The most important factors for passenger transports are travel times, a competitive price and good quality (including reliability of services). To limit travel times, a high average speed is important. This is connected to a high maximum speed (in some cases including rapid braking and accelerations) and a proper timetable. Today the limit for daily operation of a high-speed train is some 300–350 km/h. This limit is mainly based on what is economically feasible. By technical development, this limit has continuously been pushed higher. In the 1930s, the speed record for steam engines was some 200 km/h. The top speed record for an electric high-speed train today is 576 km/h, as set in 2007 by a TGV train. There is a clear connection between the top speed record and the highest allowed operating speed for commercial trains. The top speed record has been doubled every 60 years. If this trend will continue, there will be trains in operating at 500 km/h in 2050. The development is shown in Figure 1.2.

In Figure 1.3 the maximum train speed in Spain is shown. On conventional lines, it increased from 160 to 200 km/h in the 1990s. On high-speed lines, it has reached 300 km/h through the introduction of new lines and vehicles. The Spanish high-speed record was reached 2006 with 403.7 km/h. The axle load on the Spanish network was increased from 20 to 23 tonnes in 1980. On high-speed lines, it is 17 tonnes/axle.

After investigating the diagrams in Figures 1.1 and 1.2, we believe that requirements on upgrading infrastructure to meet new demands are a reality of great importance. At the same time, it is known that some of today's restrictions are easy to meet while some other are difficult, costly and sometimes impossible to overcome with realistic measures. Therefore, a systematic approach to evaluate the impact of track upgrading and address the issues is of great value. This is the background to the current deliverable.

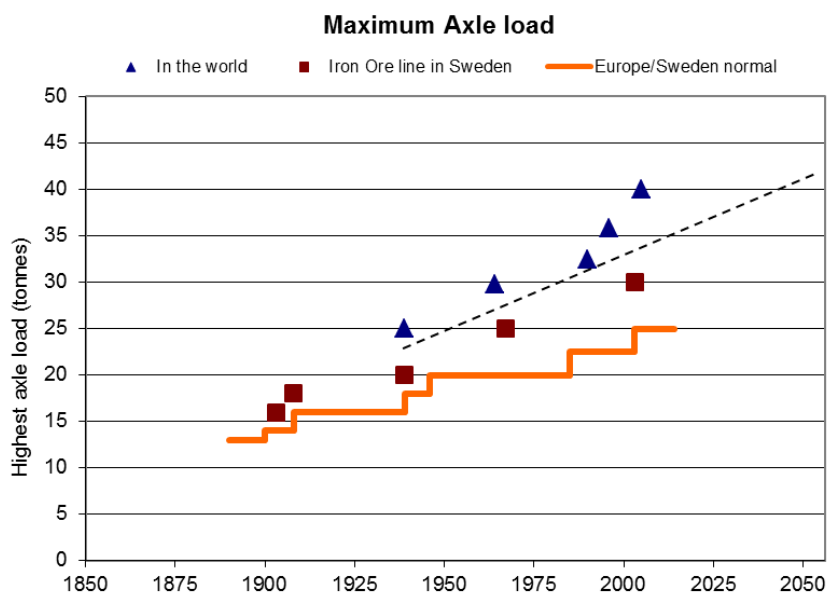

FIGURE 1.1: DEVELOPMENT OF MAXIMUM AXLE LOADS IN THE WORLD, EUROPE AND FOR THE IRON ORE LINE IN SWEDEN WITH INDICATED TREND LINE TO 2050. SOURCE: KTH RAILWAY GROUP (FRÖIDH-NELLDAL).

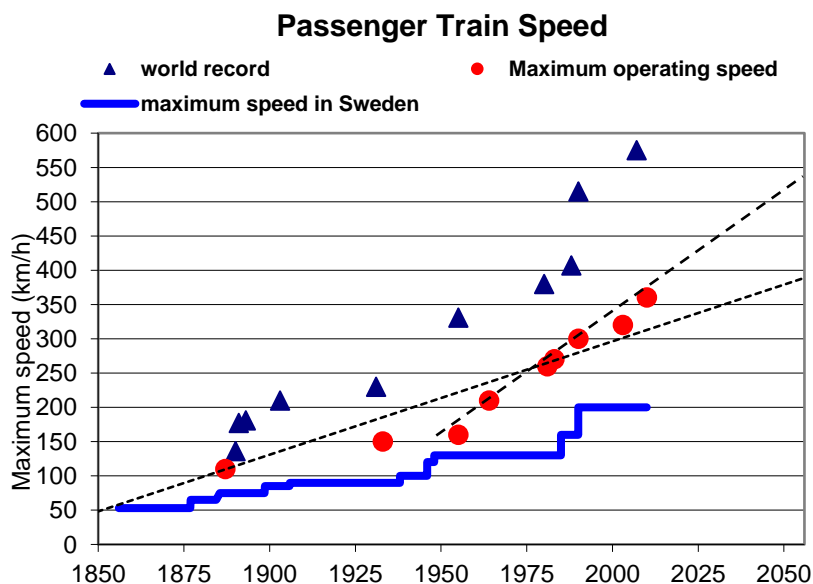

FIGURE 1.2: DEVELOPMENT OF WORLD SPEED RECORDS FOR PASSENGER TRAINS, MAXIMUM OPERATING SPEED IN THE WORLD WITH INDICATED TREND LINE TOWARDS 2050. ALSO MAXIMUM OPERATING SPEED IN SWEDEN IS SHOWN. SOURCE: KTH RAILWAY GROUP (FRÖIDH-NELLDAL).

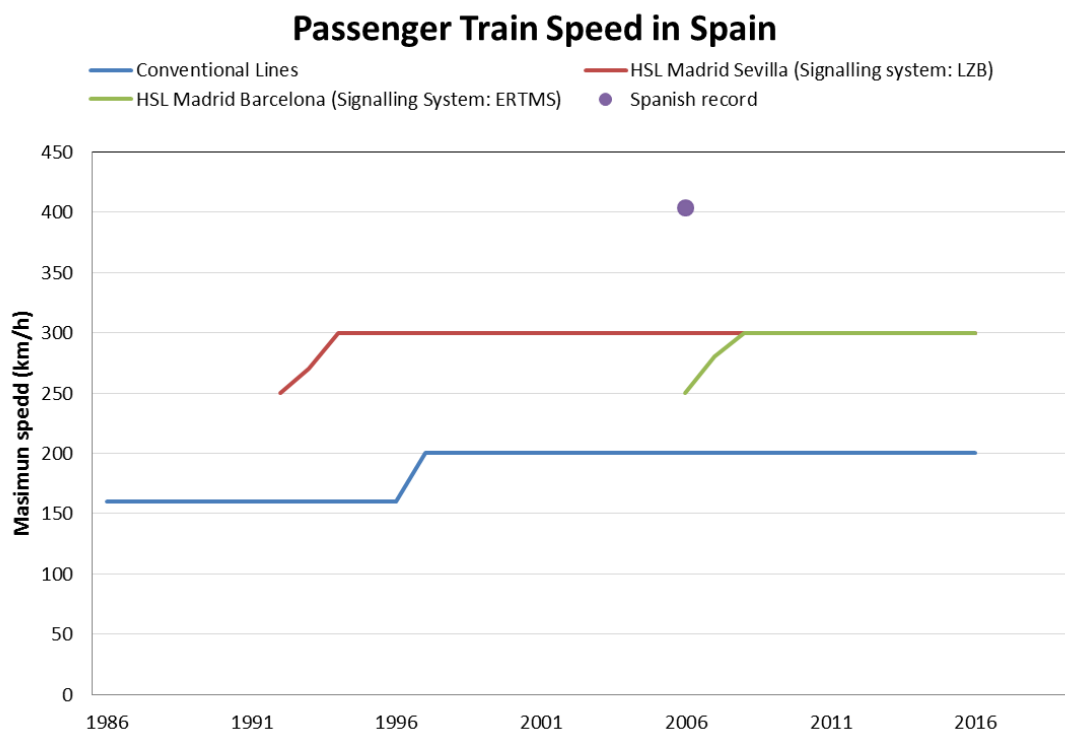

FIGURE 1.3: PASSENGER TRAIN SPEEDS IN SPAIN 1986–2016.



## 2. Objectives

---

The objective of the current report is to facilitate upgrading in a methodical, (cost-) efficient and environmentally friendly way. To this end, the guideline will contain clear descriptions and recommendations. It can be considered as a combination of checklists, functional requirements and overviews of potential possibilities of analyses and actions. However, foremost it outlines a structured way of working with the upgrading process.

Sometimes clear recommendations on actions are not possible to give (e.g. because the recommendations are intended to cover a very broad range of upgrading scenarios). In such cases references to state-of-the-art knowledge in the area will be given.

The guideline is mainly intended to provide support to infrastructure managers that upgrade infrastructure in order to meet new operational and market demands. However, the infrastructure performance must be adopted to customer needs and allowed societal costs. This will also affect the wagon and train configurations and by that the rail network and the infrastructure standard, as described in next section. For this reason, the guideline should be valuable for all parties working with upgrading or operation under upgraded conditions, e.g. operators, industry (both on the train and on the track side), maintenance contractors etc.

In upgrading substructures, the objective is a better understanding of existing methods for subgrade assessment, with special focus on high-performance methods such as stiffness measurement and/or geophysical inspections. The aim is to evaluate the subgrade quality along the whole railway line prior to infrastructure upgrading. In cases where the subgrade condition does not meet the required performance, strengthening will be necessary. To this end, the latest knowledge in improvement methods is reviewed, with a close look at the impact on train operations.

For bridges, the objective is to provide tools so that the assessment and upgrading can be done in a structured, (cost-) efficient and safe manner. Several EU-projects have shown that most bridges have a hidden capacity and that it is possible to quantify and utilize it. The objective is to present methods to do this for common bridge types. If the added capacity found is not sufficient, adequate strengthening and upgrading methods are proposed and exemplified.

For tunnels, achieving increased loading gauges is the main challenge. The objective is to present best current practices and to provide examples on what can be achieved.

For culverts and retaining walls, the objective is to exemplify problems that may be encountered and to present methods to overcome these. In addition, the aim is to provide some good examples on how upgrading can be performed.

To handle the effects of upgrading on tracks, switches & crossings is very much a question of having control over the resulting deterioration. Therefore, the main objective is to understand, quantify and limit different modes of deterioration. To this aim, a two-level scheme of successively refined analyses

gives the possibility to better understand and predict deterioration with a focus on the most important problems. The chapter also describes maintenance routines that can address problems resulting from upgrading.

## 2.1 HOW MARKET REQUIREMENTS AFFECT TRAIN, VEHICLES AND INFRASTRUCTURE PERFORMANCE

There are different requirements for development in different railway markets. These will affect the future performance needs, and thereby the requirements of the infrastructure, see Figure 2.1. For heavy freight, such as steel and iron ore, there is often a request for higher axle load and load per unit length, which will affect the track, supporting structures, and the substructure. For semi-finished goods, there are sometimes requests for higher axle loads and wider loading gauges. For voluminous goods, there is typically an ambition towards wider loading gauge and longer trains.

For intermodal transports, the typical request is for a higher loading gauge and longer trains. This will affect the requirements for infrastructure in different ways. A higher and wider gauge will affect the tunnel profile and bridge structure to accommodate the freight. Higher axle load will affect both the track and the substructure to allow heavier loads. A request for higher linear load will primarily affect bridges and culverts to be able to carry a higher load per unit length without premature deterioration.

Markets	Train parameters				Infrastructure parameters			
	Linear load	Axle load	Gauge	Train Length	Track and S&C	Sub-structure	Structure	Network
Raw material / High density	High	High	Low	Short	Low speed	Very stable	Very stable	Normal sidings
Semi-manufactured Medium density	Medium	High	Wide	Medium	Medium speed	Very stable	Very stable	Normal sidings
Manufactured Medium density	Medium	Medium	Wide	Medium to long	Medium speed	Stable	Wide gauge	Long sidings
Intermodal Low density	Low	Low	High	Long	Higher speed	Stable	High gauge	Long sidings

FIGURE 2.1: EXAMPLES OF MARKETS, AND PERTINENT AFFECTED TRAIN AND INFRASTRUCTURE PARAMETERS (NELLDAL, KTH 2015)

## 2.2 THE NEED FOR A SYSTEM APPROACH

All improvements of the rail system must be based on a system view of the railways, as illustrated by the freight system in Figure 2.2. The customer's transportation needs put demands on the wagons. The wagons are coupled together into trains where available tractive power is taken into account. The train utilises the infrastructure with a certain performance along a link and ultimately in a network from origin to destination. The intention is to analyse the railway system from its actual performance today to what is planned for the future and what is optimal from a market point-of-view if the entire system is considered.

For the traffic situations, the objective is to point out what is possible to do with the trains and operation of the freight system. This will include effects on cost and capacity and relations to infrastructure performance as further described in respective chapters.

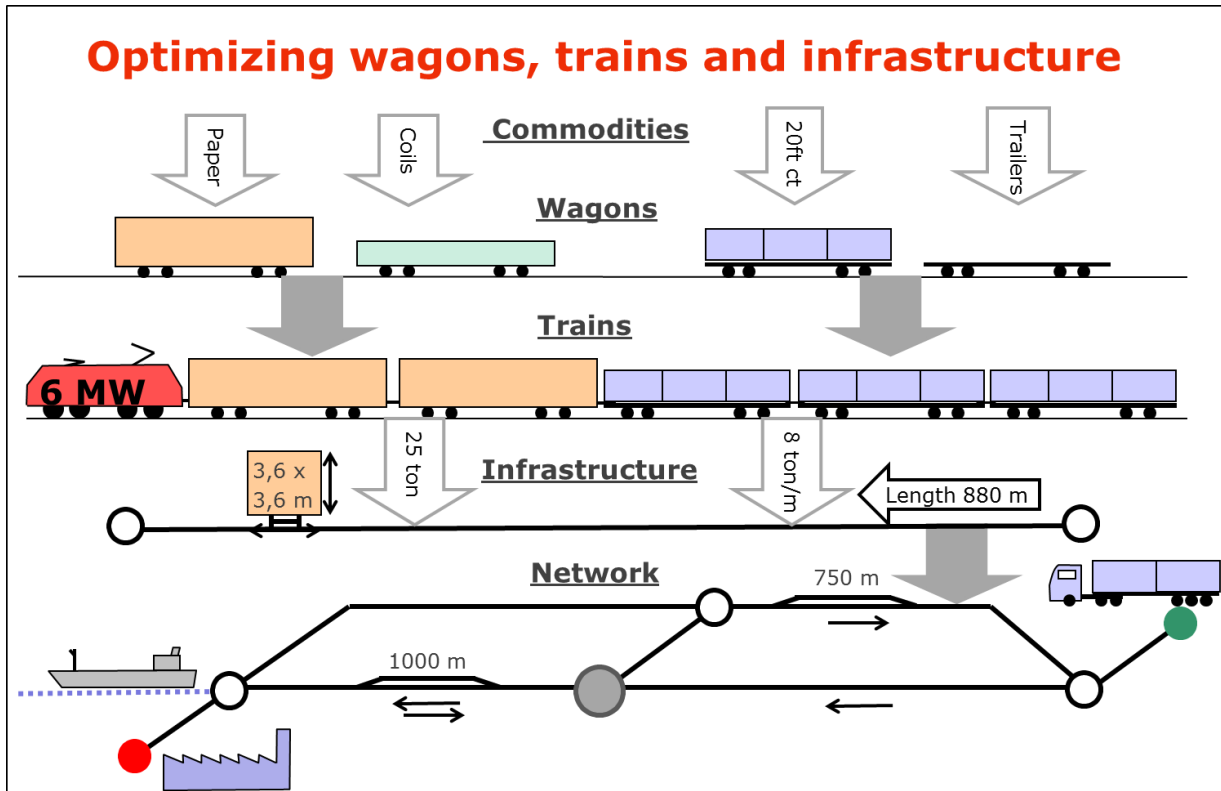

FIGURE 2.2: PRINCIPLES FOR OPTIMISING WAGONS, TRAINS AND INFRASTRUCTURE. SOURCE: KTH RAILWAY GROUP "ROADMAP FOR DEVELOPMENT OF RAIL AND INTERMODAL TRANSPORTATION" (NELLDAL, KTH 2013).

### 3. Infrastructure – general topics

In chapter 4 to 12 different types of the infrastructure are described. The purpose is that the chapters can be used stand-alone references. These chapters often start by outlining a structured work process for assessment. This is important since historically too many upgrading projects have not followed a well-thought-out process. A structured approach to upgrading has several advantages such as

- Provides a better overview of the important problem early so it is possible to focus the efforts in an optimal way
- Avoids unnecessary investigations
- Reduces investment costs
- Includes an assessment of the environmental impact.
- Reduces traffic disturbance.

Another important reason to follow a well-defined work process when assessing upgrades is that it is then easier to employ tried and well-known practices.

In several chapters, it is not possible to make general recommendations for detailed work processes mainly since the suitable approach depends on the conditions at hand. Here examples that give guidance how to solve the demands are instead provided.

#### 3.1 INTRODUCTION

The stresses from applied wagon load decrease as you move from the top of the rail down to the substructure and supporting structures, see Figure 3.1.

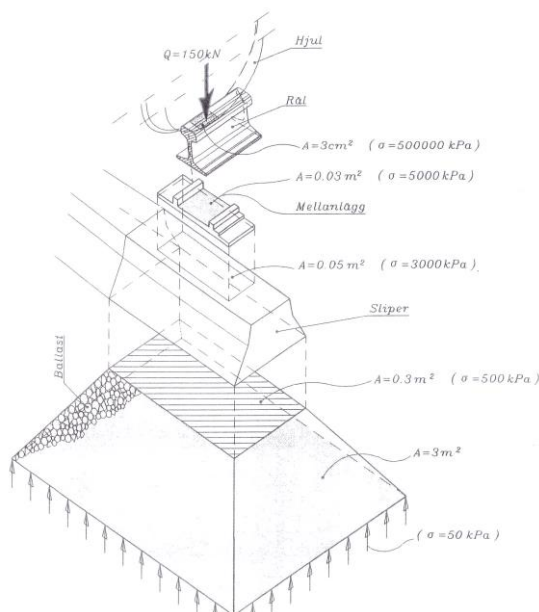

FIGURE 3.1 STRESSES MAGNITUDES ON DIFFERENT COMPONENTS (SAHLIN O SUNDQUIST, KTH 1995)

This means also that the nature of deterioration for different parts of the track structure differs depending how far you are from the applied contact load. For example, deterioration of the track structure is dominated by different fatigue phenomena, whereas the substructure and the main structure of large bridges are mainly subjected to a (quasi-)static load. Between these two extremes there is a mixture which is quite complex.

This is also the reason why different design methods are used for different parts of the track structure as detailed in the following chapters.

### 3.2 DIFFERENT TRAFFIC DEMANDS AND OPERATIONAL ENHANCEMENTS

Different traffic demands and operational development have various influences on different types of infrastructure. In the following chapter, different measures of train and wagon performance will be analysed. Note that modifications of these will also affect the requirements of the infrastructure as discussed in the subsequent chapters.

- Increased train weight
- Longer trains
- Higher axle load and meter load
- Higher speed
- Increased loading gauge
- Combinations of these measures

The new traffic situations above have different impact on different types of structures as summarized in Table 3.1.

For bridges, the highest impact comes from increased axle loads and meter loads. Longer trains and increased train weights have some impact, whereas higher speeds on freight trains has little impact and increased loading gauges usually has no impact.

For tunnels, the highest impact comes from increased loading gauges, whereas other changes usually have no impact. For culverts, the greatest impacts are usually the same as for bridges.

For common retaining walls that support masses beside the rail but not under it, the traffic situation has little or no impact. For the case of retaining walls that support the track, the axle loads and meter loads may have great impact.

**TABLE 3.1. IMPACT OF DIFFERENT TRAFFIC SITUATIONS ON DIFFERENT TYPES OF STRUCTURES.**

Type of structure/ Traffic situation	Sub-structures	Bridges	Tunnels	Culverts	Retaining walls	Track	Switches & Crossings
<b>Longer trains</b>	Some impact	Some impact	No impact	Some impact	No impact	Some impact	Some impact
<b>Increased train weight</b>	Some impact	Some impact	No impact	Some impact	No impact	Some impact	Some impact
<b>Increased axle loads and meter loads</b>	Great impact	Great impact	No impact	Great impact	Some impact	Great impact	Great impact
<b>Higher speeds on freight trains</b>	Some impact	Little impact	No impact	Little impact	Little impact	Some impact	Some impact
<b>Increased loading gauges</b>	No impact	No impact	Great impact	No impact	No impact	No impact	No impact

## 4. Substructure

---

### 4.1 ASSESSING SUBSTRUCTURE CONDITIONS

Over the course of time, permanent ways have been adapted to increasing requirements. Ballast tracks today allows speeds of over 300 km/h and carry axle loads in excess of 40 tons. The substructure and earth structure, however, has not progressed in the same way. Due to future demands for faster and heavier transports (see chapter 1), the railway subgrade can thus experience problems, such as reduced stability, increase of settlements, and vibration problems. These issues have an adverse effect on the safety, reliability and economy of the railway operations. Therefore, it is necessary also to upgrade the subgrade in such a way, so it will withstand the new loading conditions.

Improvement of the subgrade could also be necessary in cases where failures occur. In both cases of upgrading and repair, it will be necessary to first assess the substructure condition, then to evaluate existing and required subgrade quality, and finally to decide on and design strengthening measures. The flow chart in Figure 4.1 shows both scenarios and a proposal for a work processes to assess the substructure.

A key point in improving subgrade conditions is an understanding of what the current conditions are and what implications these will have on the operating traffic. To this end, this guideline will support IMs in subgrade assessments. One key issue here is to interpret and compare results obtained by different measurement techniques and recommend suitable methods. In for example INNTRACK a number of techniques including various geophysical methods, rolling stiffness measurement methods and methods able to obtain point-wise depth dependent profiles of the subgrade resistance were investigated. See e.g. Ekberg and Paulsson (2010) for more details and references to additional work.

Knowledge about the condition of the different track components along the railway lines is vital in performing optimal track maintenance. This knowledge is gathered with the help of inspections as well as manual and automatic measurements. Regarding railway substructure, most of the imperfections are visible as track geometry irregularities. Therefore, the most important inspection is an accurate measurement of spatial and temporal changes in track geometries. Furthermore, to be able to determine the root cause of a problem or to conclude how changed traffic conditions will affect the track, additional measurements or visual inspections might be needed.

The following sections deal with the assessment of the railway substructure. First, the factors and mechanical parameters, which can better inform about the substructure condition are discussed. Then, different methods and techniques appropriate to assess the substructure quality are described.

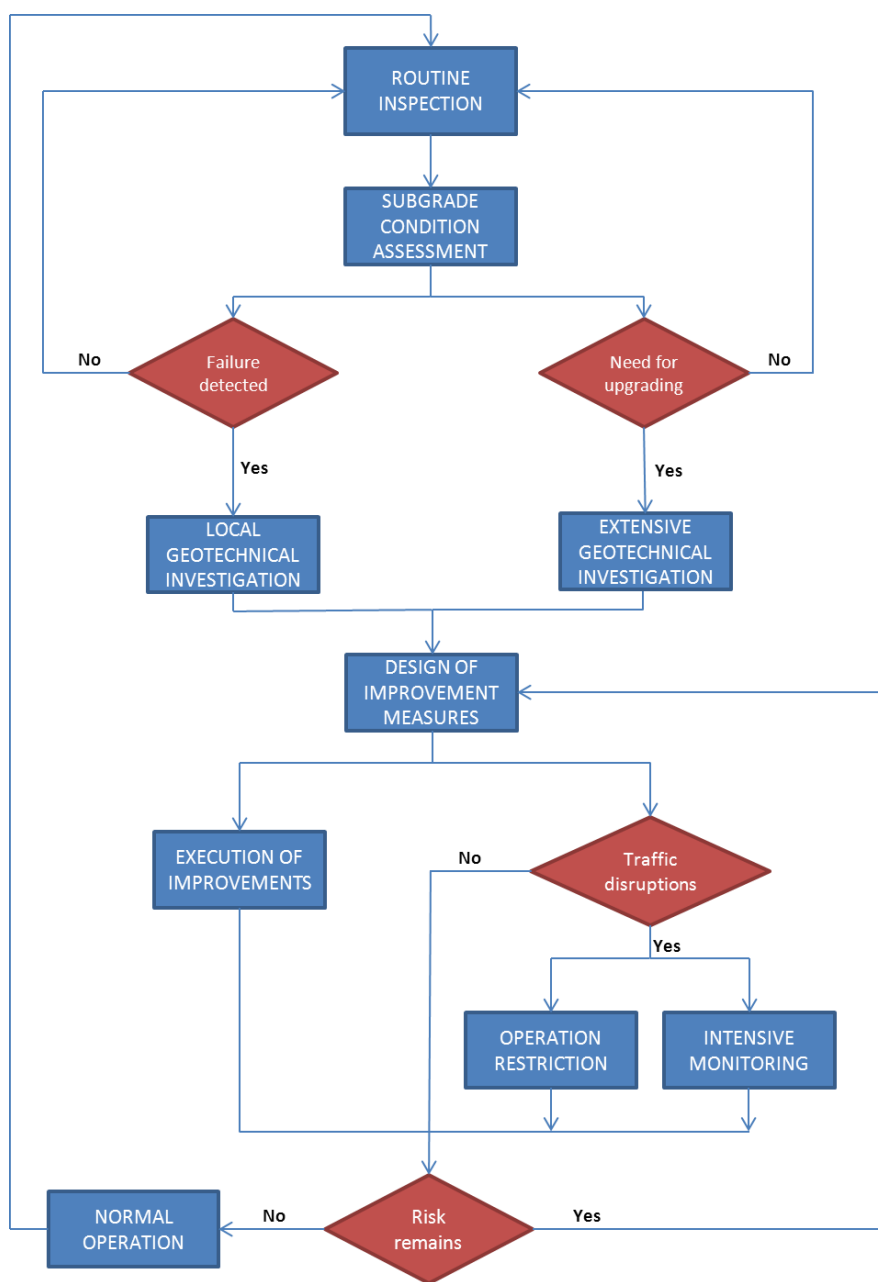

FIGURE 4.1 STRUCTURED APPROACH FOR ASSESSMENT, IMPROVEMENT AND FOLLOW-UP OF SUBGRADE CONDITIONS.



#### 4.1.1 OVERALL ASSESSMENT OF SUBSTRUCTURE CONDITIONS

##### SUBGRADE CONDITIONS AND TRACK GEOMETRY DETERIORATION

Permanent deformations (settlements) along the track and in transition zones are related to vertical loads and to the geotechnical properties and conditions of substructure materials. Drainage plays an important role regarding the stability of the subgrade: The layers of sub-ballast and subgrade generally contain moisture. These layers perform best under cyclic load when sustaining an intermediate moisture state. The change of the moisture level over time affects the stress state in the granular material leading to variations in pore pressures and – as a result – in overall material behaviour. In regions subjected to frost this effect can be dramatic.

Under load, track settlements often tend to be progressive and may increase in magnitude over time. This effect is due to dynamic effects and induced by gradual increases in loads from passing trains. Two parameters related to the substructure especially influence the track geometry degradation:

- Differential settlement between adjacent sections of the track;
- Stiffness characteristics of the subgrade.

Differential settlements occur whenever two segments of the railway track settle at different rates. The running surface deviation that develops in this situation can contribute to dynamic loads as high as three times the static wheel load. Settlements also at plain track can vary a lot due to geotechnical issues affecting the subgrade performance. These can be low strength soils, deficient soil compaction, poor drainage, and erosion. Moreover, environmental factors such as wet/dry and freeze/thaw cycles can affect the subgrade behaviour. In summary, settlements in granular substructure materials as well as deformations in superstructure components are influenced by the geotechnical conditions of the involved materials in terms of compaction and saturation.

The stiffness characteristics of the subgrade can also have a relevant impact on track degradation, as discussed in more detailed in the following section.

##### TRACK STIFFNESS AND ITS IMPACT ON THE MECHANICAL BEHAVIOR OF THE TRACK

It is generally assumed that increasing track vertical stiffness contributes to better support of the influencing traffic loads (static and dynamic) thus reducing track deterioration geometry rates. A minimum track bearing capacity and stiffness is required in order to ensure that the rolling stock would never submit the structure to loads so high that they endanger the structural strength (and sometimes the onset of rapid deterioration). This may however happen in cases of excessive track settlements when high bending stress in the rails might occur. However, excessive vertical stiffness can also be a problem due to the increase of track dynamic loads, as shown since the results published by Prud'homme (1970). Based on this reasoning, in the last decades, several authors and research projects have been discussing in the literature the importance of track vertical stiffness and which should be its appropriate or optimum value for a given railway track. Example on this is, e.g. Sussman

et al., 2001; Dahlberg, 2003; Teixeira, 2003; Hunt, 2005; López Pita et al. 2004; Iwnicki, 2006; Li and Berggren, 2010; Puzavac et al., 2012; Andersson et al., 2013. These are mentioned from the last decade and among many others. The global conclusion is that a high track stiffness of the substructure is recommended, although modulated with a good elasticity of the superstructure to reduce dynamic loads and its impact (e.g. acting soft railpads, sleeper spacing, USP, UBM...).

Track stiffness of the substructure is highly influenced by the natural geological profile characteristics. Note that the substructure may include several layers of soil material with different characteristics, hence the total track stiffness will be the combination of the stiffness of the different soils. The subgrade is in fact the most variable element of the track structure: it consists of different materials, which may be vulnerable to weather conditions and suffer seasonal thickness variations due to hydrologic and climate conditions low temperature and therefore induce variations on its elasticity modulus.

Since the subgrade condition is subject to weather, extremes of temperature and moisture, the track stiffness may also vary with seasonal changes.

#### INFLUENCE OF (VARIATIONS OF) TRACK STIFFNESS

---

Track stiffness varies fairly randomly along the track. Variations between bridges, tunnels and natural platforms are the most common examples of important stiffness variations. However, even in plain track on a natural platform important stiffness variations may often occur. Several causes can contribute to these stiffness variations. Some of these are:

- transition zones between landfill
- excavations sites or other types of constructions
- geology of the site
- embankment material type
- thickness of track bed layers
- deficient compactness
- presence of culverts or small underpass structures
- moisture content in the subgrade
- harsh seasonal climate conditions where freeze-thaw cycles may induce variations on track stiffness if the track is not correctly designed for dealing with such conditions.

Surprisingly, research has shown that even in high-quality railways, where the design and construction of the track structure are carefully monitored, the same variability in support conditions appear (Teixeira, 2003). Several authors, such as Li and Berggren (2010), have demonstrated that varying track stiffness causes variations in dynamic loads. This usually causes differential settlements and consequently differential track geometry deterioration that continually grows if not properly maintained. Measurements have shown that larger geometry defects tend to coincide with sections of sudden stiffness variations (Berggren, 2009; Burrow et al., 2009).

A recent study performed by IST (Ribeiro, 2014) in collaboration with EBER Dynamics AB further confirmed the possible influence of vertical track stiffness on track geometry degradation. The study assessed data from stiffness measurements recorded in 2012 with the IMV100 see Figure 4.2 against the maintenance history and longitudinal level deterioration rates of the Iron Ore line in North Sweden. The analysis suggests a correlation between higher rates of degradation of local defects and sudden stiffness variations, as well as evidence that higher stiffness variations tend to have a correlation to higher frequencies of maintenance operations.

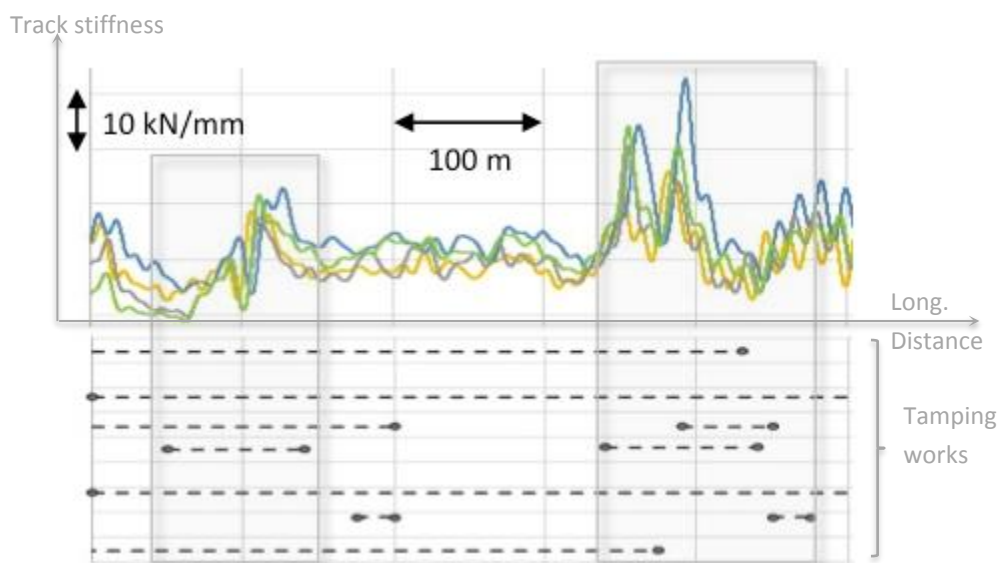

FIGURE 4.2 – REGISTERS OF TAMPING OPERATIONS ASSOCIATED TO SUDDEN STIFFNESS VARIATIONS. SOURCE: RIBEIRO (2014)

#### THE ROLE OF TRACK STIFFNESS MEASUREMENTS IN TRACK MAINTENANCE AND UPGRADING

Given the important role played by subgrade stiffness, the measurement of track stiffness has a great potential for track maintenance management as an indicator of the root causes at problem sites as well as revealing needs for track upgrading especially when the accommodation of higher speeds and/or axle loads are considered.

Measurement of track irregularities is the most used automated condition assessment technique in railway maintenance. Most problems with the track (at least the ones concerning ballast and substructure) will be visible as track irregularities. However, the root cause of the problem cannot be detected with the help of track geometry measurements. In these cases, track stiffness measurements can be a valuable complement. However, it is also important to be aware that track stiffness measurements cannot indicate the root cause of a problem in all cases.

The main causes of subsoil problems are described by Li and Selig (1995) as:

- Load factor: there are two types of load factors, material dead-weights and repeated dynamic loading;
- Soil factor: a problematic subsoil will not generally consist of coarse-grained soils (gravel and sand) but most likely will be fine-grained soils (silt and clay) due to the lower strength and permeability of the latter materials;
- Soil moisture: almost every subsoil problem can be put in relation to high moisture content in the fine-grained soil. The presence of water in the subsoil can reduce the strength and stiffness of soils dramatically;
- Soil temperature: soil temperature is of concern when it causes cycles of freezing and thawing.

Most often, a subsoil problem area will involve several of the above-mentioned factors.

In general, the common track problems may be related to track stiffness and maintenance actions as summarized in Table 4.1.

**TABLE 4.1 – RELATION BETWEEN STIFFNESS AND TRACK PROBLEM/MAINTENANCE.**

Parameter	Problem	Maintenance/Mitigation
Low track stiffness	Poor or weak subgrade soil	Substructure design Stabilization of subgrade soils Reinforcement of soil strength
Variable track stiffness	Variable track support (stiffness or modulus)	Matching rail seat pads Substructure redesign

Whenever low values of track stiffness are recorded, it most likely indicates a weak subgrade condition at the location since subgrade properties most influence the value of track stiffness. Maintenance for these conditions can involve design and reconstruction of the track substructure layers, possibly in conjunction with some geotechnical measure regarding soil reinforcement (Sussmann et al., 2001).

Variable track stiffness indicates conditions in which a rapid variation in track support at the design load occurs. The variation in track stiffness results in distortion of an initially smooth-running surface due to differential elastic track deflection that may induce also irreversible settlements. Methods used to improve this track condition include design of rail seat pad stiffness, design of the substructure, and use of ballast mats. Suiker and Esveld (1997) and Lundqvist (2005) have presented research within the area of stiffness variations. López-Pita and Teixeira (2001; 2002) and Grainger et al. (2001) also argued for the importance of adopting a maximum variation criterion, i.e. the need to assure the homogeneity of track stiffness.

#### **THE ROLE OF TRACK STIFFNESS MEASUREMENTS IN MITIGATING NOISE AND VIBRATION**

---

Noise problems originate most often from the superstructure and especially the wheel–rail contact. The main influencing factors are rail and wheel roughness, track receptance, wheel receptance and the decay rate of the rail. For noise, only frequencies in the audible band are of interest (20 – 20000 Hz). The upper limit regarding emission from the track is 2000 – 5000 Hz (Hildebrand, 2001; Aknin and Chollet, 1999). There is of course noise at higher frequencies, for example wheel and braking noise, but the track (rail) is not dominant. Jones and Thompson (2001) stated that the noise radiated by the track is strongly related to the stiffness of the rail fastening, in particular the rail pad between the rail and the sleeper. Soft pads cause the rail to become uncoupled from the sleeper, which minimizes noise from the sleeper but allows the rail to vibrate more freely. Waves can therefore travel over a greater distance and the noise from the rail is increased. Conversely, with stiff pads the contribution from the rail is reduced but noise emitted from the sleeper is increased.

Concerning ground borne vibration problems, we can divide the vibration path into source (train/track), way of propagation and receiver (buildings etc.). With track stiffness measurements, it is obvious that only the track can be measured and not the way of propagation between the track and the receiver. Ground borne vibrations are propagated through the soil, meaning that a soil with low stiffness and/or a clear resonance can propagate vibrations easily. However, the measured track stiffness is the total stiffness and does not only consist of the soil stiffness. A vibrating clay soil with a high embankment can have the same average stiffness as a normally vibrating gravel soil with a low embankment. Smekal et al. (2003) showed an example of how the low frequency soil properties can be filtered out with the help of stiffness measurements at different frequencies, thus leading to identification of potentially problem sites regarding vibrations. Berggren (2005) demonstrated how soft soil properties could be estimated from dynamic stiffness measurements. See also section 4.1.3.

#### **4.1.2 METHODS FOR SUBGRADE QUALITY ASSESSMENT**

Several methods might be used to assess the quality of the substructure. The main techniques regarding measurement of substructure stiffness and geophysical inspection of the subgrade condition are discussed in the following sections.

#### **TRACK SUBSTRUCTURE STIFFNESS MEASUREMENT**

---

Different ways of measuring vertical track stiffness have been developed by organisations throughout the world. Until today most used methods consisted in standstill measurements by simulation of vehicle loadings or measurement of parameters associated to subgrade material properties. These measurements were often used for research purposes (Berggren, 2009; Hunt, 2005). In contrast, rolling measurement techniques have the potential of being used on a regular basis for maintenance purposes. They have been applied successfully in the last years and research for improvements is still on going.

The research and improvement of measurement techniques, especially rolling measurement techniques, will allow an improved data interpretation. These results will be key for optimal planning of upgrading and maintenance activities and consequently optimal use of the maintenance budget. The appropriate equipment must be selected based on the frequency of measuring track stiffness (Berggren, 2009). As the same author states, “static and low frequency dynamics of the track are mostly related to geotechnical and geodynamical issues” such as bearing capacity of the subgrade, ground borne vibrations and soft-soil related problems while “high frequencies relate to problems associated with noise and train–track interaction forces”, being useful when considering the upper layers (Andersson et al., 2013).

#### STANDSTILL MEASUREMENTS

---

Standstill measurements are executed at discrete intervals. According to Berggren (2009), there are four main standstill devices used for measuring vertical stiffness:

*a) Instrumentation of track components*

The instrumentation of track components – e.g. with the attachment of accelerometers, displacement sensors or strain gauges – to measure the effect of the rolling stock on the structure in a set of sleepers, and/or rails, is the simplest method for measuring the vertical track stiffness. Stiffness is then related to the obtained load–deflection diagrams.

*b) Impact hammer*

The controlled impact of a handheld hammer equipped with a force transducer on the head, to measure impulse load, on an instrumented rail or sleeper is another way of standstill vertical stiffness measurement. This technique consists on measuring the impulse force of the hammer and the acceleration registered on the transducer. In this manner, the transfer function on the impact surface is obtained. Depending on the material used to cover the hammerhead, different frequencies can be recorded (from 50 Hz up to around 1500 Hz). For noise and vibration work this is a reasonable method but not for track deterioration investigation (Hunt, 2005).

*c) Falling Weight Deflectometer (FWD)*

The Falling Weight Deflectometer was adapted by the railway industry after being originally developed for evaluation of the static stiffness of the trackbed layers, including the subgrade, on highways (Bold, 2011; Shein et al., 2007). The testing method consists in dropping a mass from a known height onto a footplate placed upon a sleeper disconnected from the rails, to simulate traffic loading. Geophones placed at various distances from the point of impact automatically record the deflection through the measurement of the surface velocity and its integration (Berggren, 2009). The requirement of disconnecting the sleepers for applying the test makes this procedure very time-consuming and expensive (Bold, 2011).

*d) Track Loading Vehicle (TLV)*

The aim of this technique is to use hydraulic jacks for loading the track with the equipment’s own weight and then measure the applied deflection. The latter can be made through a laser system

(McVey et al., 2005). The weight is usually applied on the rails but similarly to the Falling Weight Deflectometer technique, sleepers can also be disconnected and loaded. Some available equipment is able to excite dynamically the track up to 200 Hz (Berggren, 2009).

The Swedish track loading vehicle (TLV) in Figure 4.3 has a weight of 49 tons and can load each rail statically up to 150 kN and excite dynamically up to 200 Hz. In addition, lateral stability/stiffness can be measured.

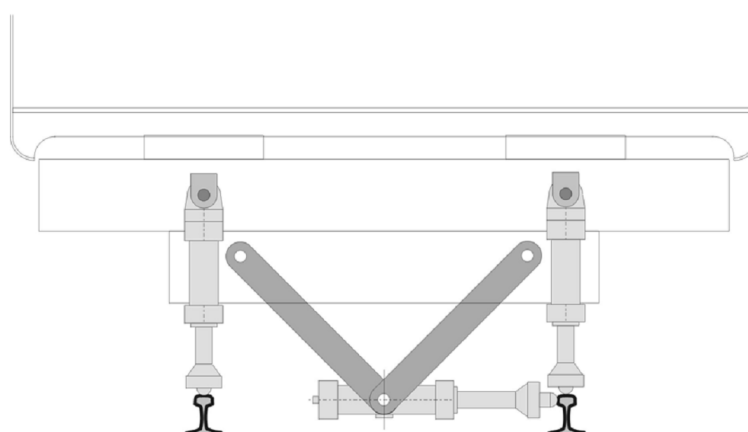

FIGURE 4.3 – THE VERTICAL AND LATERAL HYDRAULIC ACTUATORS OF THE SWEDISH TLV.

#### ROLLING MEASUREMENTS

If track vertical stiffness is investigated over large distances or even the whole track, standstill measurements are virtually impossible to carry out, as they are very time-consuming and expensive. Therefore, rolling measure vehicles have been developed by several organisations (Berggren, 2009). There are two main development approaches: one is based on dynamic measurements on a single axle, and the other is based on laser-measurement of the vertical deflections under applied loads.

In all approaches, it is important to discriminate different conditions or defects that may influence the continuous measurement of track vertical stiffness. That discrimination is made based on the wavelength ( $\lambda$ ) interval of some of these defects (Berggren et al., 2002), Table 4.2. This is an important aspect for choosing excitation frequencies for measuring (Berggren et al., 2005).

TABLE 4.2 – WAVELENGTHS OF IMPERFECTIONS THAT INFLUENCE STIFFNESS MEASUREMENT (BERGGREN ET AL., 2002).

Imperfection	Wavelengths
<b>Track geometry irregularities:</b>	
- Longitudinal level	$1 < \lambda < 150$ m
- Cross level	
<b>Rail shape faults:</b>	
- Rail corrugation/roughness	$0 < \lambda < 3$ m
- Welds/joints	
<b>Discrete foundation of the rail by sleepers</b>	$0.5 < \lambda < 0.7$ m

Below some examples of measurement, techniques for rolling vertical track stiffness employed in different countries are summarized:

SWEDEN

The RSMV (Rolling Stiffness Measurement Vehicle) operates at maximum speeds of 50–60 km/h and can measure dynamic stiffness up to 50 Hz (Berggren, 2006, 2009; Berggren et al., 2002). It was developed in Sweden, by Banverket (now Trafikverket), initially as a prototype trolley that could be used together with the Swedish TLV (Berggren et al., 2002). After successful tests, it was upgraded and built on a modified two-axle freight wagon. The measurement technique is based on a hydraulic system that dynamically excites the track at one or several selected discrete frequencies, with two oscillating masses connected to force transducers mounted on top of the axle box of one of the wheel axles (Figure 4.4). The applied force is a minimum of 180 kN regarding the static axle load and a maximum amplitude of 60 kN (30 kN per oscillating mass) for the dynamic axle (Berggren, 2009; Berggren et al., 2002, 2005). Resulting forces and accelerations are measured by force transducers and accelerometers placed on both axle boxes of the wheel-set enabling the estimation of track stiffness at different excitation frequencies (Berggren, 2009; Berggren et al., 2005).

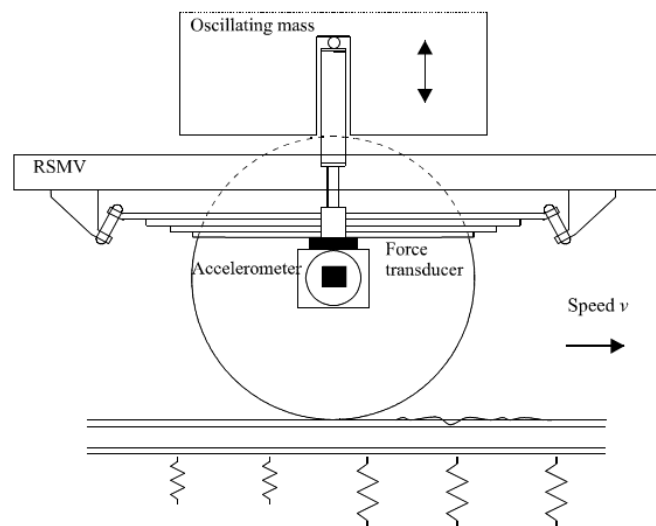

FIGURE 4.4 – MEASUREMENT PRINCIPLE (ONE SIDE ONLY) OF RSMV (BERGGREN ET AL., 2005).

USA

The Transportation Technology Center, Inc. (TTCI) developed a track loading vehicle (TLV) for measuring track stiffness at standstill and at speeds up to 16 km/h, when coupled with an empty tank car. For standstill measurements, the TLV works as previously described. The lighter vehicle has a pneumatic system for loading the track and a measurement system for measuring deflections. For obtaining the track stiffness, the difference between the



measurements with heavy (178 kN) and light (44 kN) loads is calculated (Berggren, 2009; Burrow et al., 2009). Some results from the TTCI measurements are shown in Figure 4. 5.

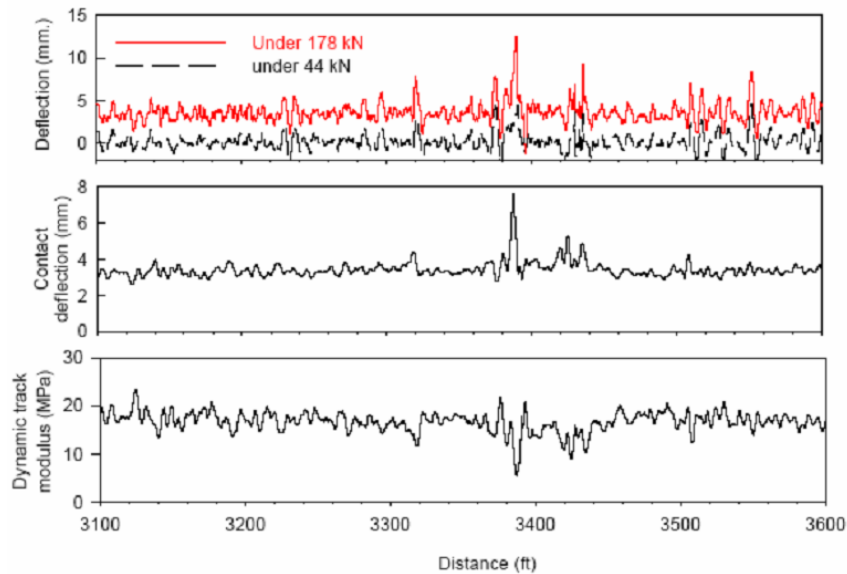

FIGURE 4.5 – EXAMPLES OF RESULTS FROM TTCI MEASUREMENTS (LI ET AL., 2002).

#### CHINA

The China Academy of Railway Sciences (CARS) developed an inspection equipment with a system that uses two cars of different weight for loading the track. The displacement is measured with two track geometry chord measurement systems. The heavier vehicle measures the track stiffness and its weight can be varied for enabling the measurement of non-linear characteristics of the track structure. The lighter vehicle is used to reduce the effect of track geometry irregularities for the recordings made by the heavier vehicle. It can measure at travel speeds up to 60 km/h (Berggren, 2009; Burrow et al., 2009).

#### FRANCE

The CETE-Normandie Centre created the Railway Portancemetre by adapting a technology used for monitoring stiffness on roads to railways (Figure 4.6). In an approach similar to that of the RSMV (although in a lighter version), a dynamic load is applied to the track through a vibrating wheel suspended by a spring and a damper. For road testing, 10 kN of static weight, 0.5 mm of theoretical amplitude, at 35 Hz is used. For rail testing these characteristics will be changed with increased loads (both static and dynamic) and possibilities to alter the frequency.



FIGURE 4.6 – THE “PORTANCEMETRE” APPARATUS (INNOTRACK, 2010).

#### SPAIN

In the INNOTRACK project, procedures to measure the track stiffness based on the use of external sensors mounted on rails were developed. These are currently used in Spain. They have been used to detect the wheel loads and rail movements induced in track by trains operating the railway lines. The wheel loads were assessed by a method based on the determination of the maximum shear stress induced in the rail cross section by the pass of the trains, while both direct and indirect methods have been adopted for measuring rail deflections.

The measurements have been achieved with the following pieces of equipment:

- Extensometer shear bands
- Laser beam sensors, see Figure 4.7
- 2 Hz geophones, see Figure 4.8

The procedure was explained in detail in the documentation of the the project INNOTRACK, see (Ekberg and Paulsson, 2010) and references therein.



**FIGURE 4.7 – LASER SYSTEM USED FOR MEASURING RAIL DEFLECTIONS DIRECTLY**



**FIGURE 4.8 – GEOPHONE OF 2 HZ PROVIDED WITH THE ADEQUATE SUPPORT TO BE CLAMPED TO THE BASE OF A STANDARD RAIL**

#### OUTCOME OF DIFFERENT MEASUREMENT TECHNIQUES

---

Vertical track stiffness measurements are unlikely to match exactly if two or more methods are used to test the same track. Some of the circumstances that might be different are summarized below (Berggren, 2009; Hosseingholian et al., 2009):

- The *static preloads* applied by each measurement equipment differ and those differences are likely to cause different recorded stiffness values;
- Some of these techniques are based on running wheel-sets which means that the track will be excited by a load passing with the vehicle speed. Depending on this running speed, the track will be excited by a specific frequency. As the dynamic track stiffness is frequency dependent, the *excitation frequency*, hence *speed*, will make the determined stiffness vary;
- The *spatial resolution* from each measurement technique may be different;
- To calculate the rail deflection based on deflections not measured directly under the wheel-set, approximations are invoked in mathematical models. These may introduce uncertainty in obtained results. Therefore, *model dependency* is another factor that may lead to variations in measured vertical track stiffness;
- *Track geometry irregularities* are likely to influence stiffness measurements since most of the available equipment usually measures track stiffness through sensors that obtain results that are a combination of deflection due to track flexibility and track geometry irregularities (mainly longitudinal level).

#### GEOPHYSICAL INSPECTION OF SUBSTRUCTURE DEFECTS

---

Geophysical investigations are based on observation of changes in physical fields. Research and retrieval of information from archival reports enables the set-up of an optimal combination of geophysical methods for an efficient diagnose. Based on the problem nature, the methods listed below are used in full combinations, incomplete combinations or separately.

- GPR (Ground Penetrating Radar);
- Resistivity profiling;
- Multielectrode (resistivity) measurements;
- Seismic methods;
- Gravimetry.

#### GPR (GROUND PENETRATING RADAR)

---

Ground penetrating radar (GPR) can provide a rapid, non-destructive measurement technique for evaluating the substructure condition of a railway track. Methods of applying GPR to railways have been developed to provide a continuous evaluation of the track substructure conditions relative to subsurface layering, material type, moisture content and density. Typically, for railroad applications the GPR equipment is mounted on a rail-vehicle with clearance between the antennas and the track surface, which permits continuous measurements to be made from above the top-of-rail at normal

vehicle speeds (Figure 4.9). Usual penetration depth in performing measurement beyond the track is 8 m (maximum) and 2.5 m within the track skeleton.



FIGURE4. 9 – GPR RAIL-SETUP WITH THREE PAIRS OF 1-GHZ HORN ANTENNAS (SELIG ET AL., 2003).

The GPR method requires transmitting pulses of radio energy into the subsurface and receiving the returning pulses that have reflected off interfaces between materials with different electromagnetic properties. This is illustrated in Figure 4.10. It is a pulse echo technique using radio energy. Antennas are moved across an area emitting a continuous series of radar pulses, and thus receiving a profile of the subsurface.

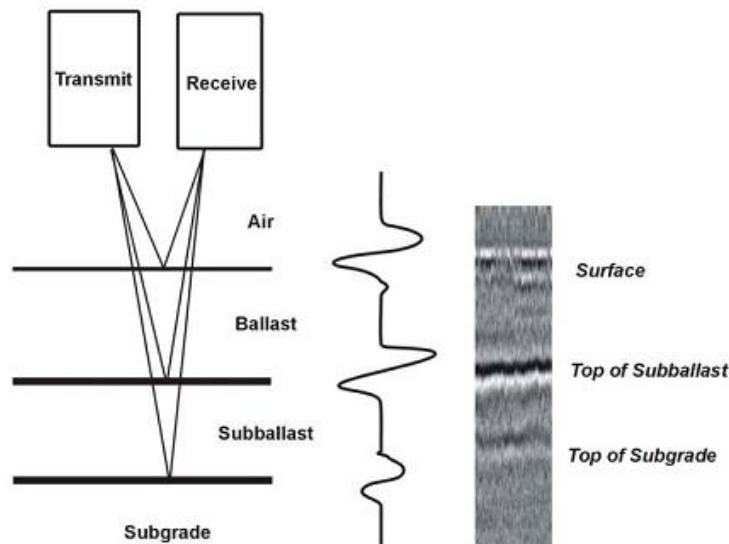

FIGURE4.10 – THE GENERATION OF A GPR PROFILE: A) TRANSMISSION PRINCIPLES; B) SINGLE GPR SCAN (SELIG ET AL., 2003).

The key material properties influencing the measurement are the dielectric permittivity, the electrical conductivity, and the magnetic permeability. These properties control the velocity with which the radio pulses travel through the material and the decay in amplitude of the pulse with distance. The pulse travels faster through a low dielectric permittivity material than a material possessing a higher dielectric permittivity. In contrast to permittivity, the conductivity of the material dictates how quickly

the pulse of radio energy decays in amplitude (attenuates) with distance. It thus controls how deep the pulse will penetrate. These two properties are the most influential.

Reflections of the GPR pulse occur at boundaries in the subsurface where there is a change in the material properties. Only a portion of the pulsed signal is reflected and the remaining part of the pulse travels across the interface to be reflected back to the receiver from another interface boundary. The time it takes the pulse to travel through the layer and back is controlled by the thickness and properties of the material. The travel time between upper and lower boundaries of a layer can be used to calculate the layer thickness by employing a known velocity.

Material and moisture variations within the track substructure cause distinct material differences that are easily recognized by GPR. Water has the highest dielectric permittivity of the materials found in substructures. It produces a strong effect on the GPR profiles. In an area where water has been trapped in the substructure, the dielectric permittivity is increased, resulting in a stronger reflection than if the material was drier. The GPR profiles are manipulated to extract layer thickness and permittivity (related to the material density and water content).

The implementation of predictive maintenance policies requires firstly a detailed knowledge of the state of the railway platform, and secondly a comparison over time to determine performance thresholds. To achieve these goals a non-invasive diagnostic tool is needed. This tool must be able to investigate continuously large sections of track with sufficient resolution and high sampling rates. In this regard GPR has been proven in the past to be the most suitable choice.

GPR is a shallow geophysical technique capable of generating 2D- and 3D-pseudocolor images of the subsurface structure. The advantage over other conventional techniques such as boreholes or trenches is that it is a non-invasive method that is also fast and versatile, with acquisition speeds up to 80 km/h.

The propagation wave speed depends on several properties of the medium that produce absorption and scattering of the signal. These variations on the pulse shape can be directly related to the various conditions of the platform. The most important parameters whose properties can be investigated with GPR in railway applications are:

- Thickness of the different layers (ballast, sub-ballast, subgrade).
- Degree of contamination of the ballast
- Moisture content of the ballast
- Possible settlement areas

To determine the thickness of each layer it is necessary to identify first the reflector for each interface (e.g. ballast–sub-ballast interface) and then the pulse velocity in that layer. Usually, the velocity is obtained by correlating the GPR information with data obtained from direct sampling of the platform (trenches or boreholes). The traditional approach is based on the interpolation of sparse data throughout long distances with the associated uncertainties. With the aid of GPR data this approach is no longer necessary and continuous information can be derived. It is also possible to directly measure

the velocity of the GPR pulse in each of the layers using variable offset measurements like WARR (Wide Angle Refraction and Reflection) or CMP (Common Mid-Point) (Jol, 2009). Such tests were done manually in the past making data collection painfully slow. The use of modern antenna arrays significantly reduces data acquisition times, which makes these kinds of techniques very valuable.

GPR pulses in ballast are affected by contamination from the fine-grained material from the subgrade. The most obvious effect is an attenuation in higher frequencies (Leng & Al-Qadi, 2009). Other visible effects are the appearance of reflectors inside the ballast, the loss of intensity of the reflector at the base of the ballast and a decrease in propagation velocity.

The pulse velocity depends on the composition of the materials and the degree of moisture and contamination (Figure 4.11). In the case of clean ballast, the velocity ranges between 0.12 m/ns and 0.21 m/ns. For ballast contaminated with fine-grained material, it ranges between 0.08 m/ns and 0.12 m/ns (Göbelet al., 1994). This property makes pulse velocity determination of utmost importance.

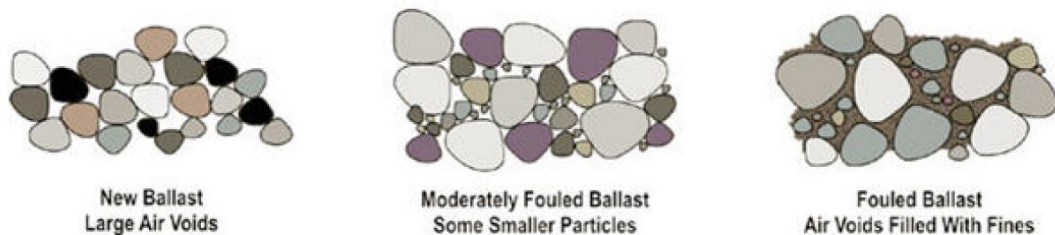

FIGURE 4.11 – DIFFERENT DEGREES OF CONTAMINATION IN BALLAST

Water content is one of the parameters that mostly affects the GPR pulse (Huisman et al., 2003) producing a large reduction of the pulse velocity and the appearance of reflectors of high amplitude and low frequency. Moreover, the thickening of the ballast layer indicates subsidence areas. The investigation of these zones by three-dimensional models contributes to detailed information of the morphology and extension, which allows considering the intensity of the deformation.

To determine the most suitable GPR system from those available in the market, a series of tests were carried out in Spain. Equipment from three different manufacturers were tested. The first test was carried out in June 2009 with a Ground Coupled system (250 and 500 MHz) from MALA Geoscience. Data were acquired every 2cm referencing the data with a submetric GPS. The second system was the Norwegian built 3D-Radar composed by an array of 21 antennae spaced 7.5cm apart (across measuring direction) with step-frequency technology allowing acquisition of data between 100 and 3000 MHz. The GPR array was installed in the front of an ADIF maintenance train (Figure 4.12). Tests were performed at low speed (4 km/h for maximum resolution) and high speed (80 km/h for low resolution). Positioning was achieved using a submetric GPS. The last system employed in this comparison was

from the Italian manufacturer IDS and composed of three aircoupled 400 MHz antennae. The system was also installed in front of an ADIF maintenance train. Measurements were done every 6 and 12cm at acquisition speeds between 60 and 80 km/h.



FIGURE 4.12. 3D-RADAR GPR SYSTEM TESTED MOUNTED ON THE FRONT OF AN ADIF MAINTENANCE TRAIN.

GPR ability as an efficient tool for ballast and subgrade condition assessment was tested. CMP measurements allow determining the pulse velocity inside the ballast layer. Using this parameter, the total thickness of the ballast layer and its degree of contamination can be determined.

Knowledge about ballast thickness variations with time will allow quickly identifying areas under subsidence and adopting correction measures before further major defects are developed.

The final goal is to efficiently plan maintenance works and to increase the safety of day-to-day operations. Pulse velocities are very sensitive to humidity and contamination of the ballast layer. This property makes pulse velocity determination a tool to pin down areas prone to suffer defects in the near future.

Finally, a better understanding of current ballast and subgrade conditions is crucial to understand future evolution in order to plan maintenance works in a proactive way. This is especially important when upgrading has taken place in order to reduce costs and increasing operational reliability levels.

#### LONG TERM SETTLEMENTS

Different kinds of track stiffness measures were evaluated within Eurobalt II and within INNOTRACK. These included stationary (standing still) measurements and measurements with the Track Loading



Vehicle (TLV); and continuous measurements performed with the Rolling Stiffness Measurement Vehicle (RSMV) (the latest).

The measured data included the evolution in time of track stiffness as well as the difference registered in these measures for adjacent sleepers and between the left and right side of the track. Track stiffness measurements from the RSMV were registered based on noise excitations performed with a speed of 5 km/h and a frequency of 3–20 Hz that allowed measuring the stiffness magnitude at different frequencies.

The obtained results enabled the identification of problematic situations such as spots where water was trapped within the substructure layers and track sections with excessive track stiffness variations due to subsurface drainage components or trenches. The evolution of the track stiffness for a given track section and an investigation of the evolution of settlements over time also permitted the recognition of weaker sections of the track. Moreover, parallel monitoring of weather conditions (soil and air temperature, precipitation and relative humidity) allowed establishing some causality between track stiffness variations and the atmospheric conditions.

In 2007 an investigation “Long term settlements in the track bed and subsoil” was carried out. It was a follow up from the EU-project Eurobalt II. Banverket continued to perform long-term measurement at Swedish test sites.

#### RESISTIVITY PROFILING

---

This technique relies on the measurement of electric resistivity of ballast. The basic measurement array is characterized by the use of two inner – potential – electrodes and two outer – current – electrodes Symmetric Resistivity Profiling (SRP). To detect thin conductors, one additional distant current electrode is used Combined Resistivity Profiling (CRP). Resistivity magnitude increase with a decline of water content and a decline of mineralization. Resistivity magnitude further rises in relation to the soil grain size curve (resistivity magnitude rises with increasing size of soil grains). The measurement proceeds in profiles/survey lines. The lines, if allowed by field conditions, are laid out in parallel with one another. The measured data is largely presented in the form of graphs. In the event that the measurement covers a more extensive area, it can be processed also in the form of resistivity contour lines.

The methods of resistivity profiling are used, for example, to differentiate clays from gravels or to follow the profile of bedrock. The method may also be applied to observe intensively water-bearing areas, and to detect tectonic lines (thin conductors). In a railway context, the recommendation is to use this method to observe the geological conditions close to the railway body and/or changes in embankment composition. Usual measuring intervals at a profile is 5 m to 10 m. Nevertheless, the method is quite undemanding regarding the instrumentation and shows high working productivity. A disadvantage of the method is potential measurement interference caused by stray currents and by the presence of conductors in the ground.

#### MULTIELECTRODE METHOD (RESISTIVITY TOMOGRAPHY)

As is the case for the resistivity profiling, this method is based on the measurement of electric resistivity in stones. However, the measurement proceeds using a computer, which allows controlling the interconnected input from tens to hundreds of electrodes. The measured data are recorded, and stored in extensive and detailed databases of apparent resistivities related to the points in the studied medium. The database of apparent resistivities is further interpreted, which allows for a reliable interpretation model of resistivity conditions with much higher confidence levels than for resistivity profiling. An example is presented in Figure 4.13. Certain special apparatuses allow interpretations in three dimensions and iso-ohmic cross sections.

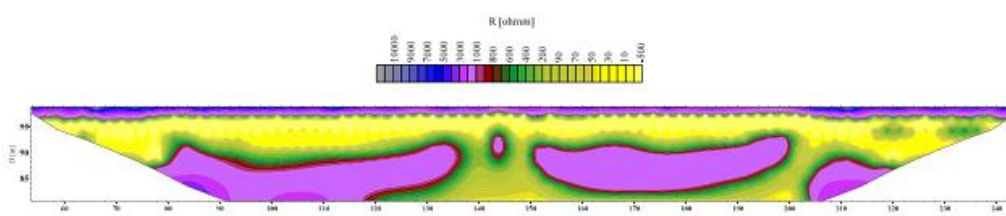

FIGURE 4.13 – EXAMPLE OF RESISTIVITY CROSS SECTION PRODUCED BY MULTIELECTRODE METHOD ON TRACK (INNTRACK, 2010).

In a railway context, the method can be recommended for detailed observation of resistivity conditions. In performing the measurement on railway tracks, most often the employed distance between the electrodes is 0.4 to 4 m. The acquired volume of information is a manifold higher than if GPR, SRP or CRP methods are employed. Disadvantages of the method is the relatively large labour needs, and the high price of the geophysical apparatus and interpretation software.

#### SEISMIC METHODS

Seismic methods are based on observation and measurement of propagation of elastic waves. Seismic hammer blows on pad (blow seismic) most often excite seismic impulses. For versions with penetration depth of more than 30 m, explosives are often used as a source of seismic impulses (dynamite seismic). In addition, vibrators can be used as a source of seismic impulses. These are able to excite frequencies in a wide range (vibrator seismic).

In the measurements, seismic sensors (geophones) interconnected with the apparatus are used. The measurement outputs have a direct link to the geotechnical properties of the medium: The velocity of seismic wave propagation is dependent on bulk density and modulus of elasticity. Rising values of the modulus of elasticity are associated to a medium showing higher solidity (the highest values of modulus of elasticity are shown by solid rocks and low values of modulus of elasticity correspond to soils). It is recommended to include seismic, especially in detailed measurement phases where shorter track segments are examined. A disadvantage of the seismic measurements is that they are labour intensive, have high processing complexity and are costly.

#### GRAVIMETRY

---

This method is based on highly accurate measurement of changes in gravity. To introduce topographical corrections, it is necessary to simultaneously perform accurate levelling. The works proceed at profiles (survey lines) and in a grid. Solid objects, such as elevations of solid rocks, show positive anomalies. Deficits of mass (such as cavities, increased porosity) show a resulting negative anomaly. A characteristic output of gravity measurements are graphs with the course of the measured and corrected gravity values, or interpreted gravity models. The models express the measured distribution of mass in a way best fitting the measured values.

The measurement interval at the profiles on railway tracks largely ranges between 0.5 and 20 metres. The measurement results have a direct relation to bulk density of the studied structures. The advantage of the work with a gravimeter is a relatively small effect of the presence of stray currents on the measurement. The final data processing requires the availability of not only the gravity data, but also precise hypsography of all measured gravimetric points and a topographic plan of the broader surroundings of the track.

#### GEOMECHANICAL INVESTIGATIONS OF SUBSTRUCTURE PROBLEMS

---

The depth of the substructure that influences the track stiffness is at least several meters below the top of the subgrade. Given that subgrade resilient modulus varies by a large amount from point to point along the track, the subgrade plays a central role in the global stiffness of the track and also influences its overall performance. When carrying out substructure assessment aimed at upgrading, it is fundamental to be able to perform an adequate analysis and prediction of the track performance as well as to identify the main causes of subgrade related performance. Hence, in order to correct substructure problems, a previous knowledge on the root causes is required.

The necessary extent of the knowledge related to the substructure condition depends on the specific problem and might include relevant information such as the depths of the distinct soil or granular layers; the identity and physical properties of the materials; and the groundwater conditions. Nevertheless, the above information is usually not known. Therefore, a field investigations and laboratory tests are often needed as supplement. The following sections identify means for obtaining information related to the causes of the substructure problems.

#### CHARACTERIZATION OF MAJOR SUBSTRUCTURE PROBLEMS

---

The root causes of an unstable substructure might be associated to any of the ballast and sub-ballast layers or to the subgrade. Very often, unstable substructures are also associated with poor drainage. Due to poor drainage, the trackbed layers may become weak and deform excessively. This leads to poor track geometry, which in turn causes higher wheel/rail forces (see (Ekberg and Paulsson, 2010)).

In the ballast layer, fouled ballast is often the major problem since it has very high stiffness and little damping, and therefore is not capable of accommodating high wheel/rail forces associated with a poor track geometry. Moreover, a saturated sub-ballast layer due to fouling materials and poor drainage

can lose its strength under repeated dynamic wheel loads, thus representing a source of instability for the substructure. It may also be frost sensitive.

A subgrade built with soft or marginal soil can become unstable either in a progressive manner or suddenly. Sudden failures rarely occur, unless there is a dramatic change of environment (such as high rainfall and flooding) or load conditions (such as a large increase in wheel loads). However, progressive deformation (shear) is relatively common whenever the subgrade is built from soft or marginal soil types. This progressive deformation can become rapid, leading to rapid track geometry degradation when speed or axle loads increase since the bearing capacity of the subgrade soils may not be sufficient to withstand the stresses caused by the increased traffic loads. In addition, poor drainage or entrance of water into the subgrade may reduce soil strength, leading to excessive deformation or unstable substructure.

Table 4.3 presents the causes and features associated to major subgrade problems. Relating a problem to its root cause is of great importance when assessing the need for rehabilitation or upgrading of the substructure.

**TABLE 4.3 – MAJOR SUBGRADE PROBLEMS, CAUSES AND FEATURES (AFTER SELIG, 2004).**

Type	Causes	Features
Progressive shear failure	<ul style="list-style-type: none"> <li>- Repeated loading over-stressing subgrade</li> <li>- Fine-grained soils</li> <li>- High water content</li> </ul>	<ul style="list-style-type: none"> <li>- Squeezing of subgrade into ballast shoulder</li> <li>- Heaves in crib and/or shoulder</li> <li>- Depression under sleepers trapping water</li> </ul>
Excessive plastic deformation	<ul style="list-style-type: none"> <li>- Repeated loading of subgrade</li> <li>- Soft or loose soils</li> </ul>	<ul style="list-style-type: none"> <li>- Different subgrade settlement</li> <li>- Ballast pockets</li> </ul>
Subgrade attrition with mud pumping	<ul style="list-style-type: none"> <li>- Repeated loading of subgrade stiff hard soil</li> <li>- Contact between ballast and subgrade</li> <li>- Clay-rich rocks or soils</li> <li>- Presence of water</li> </ul>	<ul style="list-style-type: none"> <li>- Muddy ballast</li> <li>- Inadequate sub-ballast</li> </ul>
Softening subgrade surface un sub-ballast	<ul style="list-style-type: none"> <li>- Dispersive clay</li> <li>- Water accumulation at soil surface</li> <li>- Repeated train loading</li> </ul>	<ul style="list-style-type: none"> <li>- Reduces sliding resistance of subgrade soil surface</li> </ul>
Liquefaction	<ul style="list-style-type: none"> <li>- Repeated dynamic loading</li> <li>- Saturated silt and fine sand</li> <li>- Repeated train loading</li> </ul>	<ul style="list-style-type: none"> <li>- Reduces sliding resistance of subgrade soil surface</li> </ul>
Massive shear failure (slope stability)	<ul style="list-style-type: none"> <li>- Weight of train, track and subgrade</li> <li>- Inadequate soil strength</li> </ul>	<ul style="list-style-type: none"> <li>- Steep embankment and cut slope</li> <li>- Often triggered by increase in water content</li> </ul>

Type	Causes	Features
Consolidation settlement	<ul style="list-style-type: none"> <li>- Embankment weight</li> <li>- Saturated fine-grained soils</li> </ul>	<ul style="list-style-type: none"> <li>- Increased static soil stresses from weight of newly constructed embankment</li> <li>- Fill settles over time</li> </ul>
Frost action (heave and softening)	<ul style="list-style-type: none"> <li>- Periodic freezing</li> <li>- Free water</li> <li>- Frost-susceptible soils</li> </ul>	<ul style="list-style-type: none"> <li>- Occurs in winter/spring period</li> <li>- Heave from ice lens formation</li> <li>- Weakens from excess water content on thawing</li> <li>- Rough track surface</li> </ul>
Swelling/shrinkage	<ul style="list-style-type: none"> <li>- Highly plastic or expansive soils</li> <li>- Changing moisture content</li> </ul>	<ul style="list-style-type: none"> <li>- Rough track surface</li> <li>- Soil expands as water content increases</li> <li>- Soil shrinks as water content decreases</li> </ul>
Slope erosion	<ul style="list-style-type: none"> <li>- Surface and subsurface water movement</li> <li>- Wind</li> </ul>	<ul style="list-style-type: none"> <li>- Soil washed or blown away</li> <li>- Flow onto track fouls ballast</li> <li>- Flow away from track can undermine track</li> </ul>
Slope collapse	<ul style="list-style-type: none"> <li>- Water inundation of very loose soil deposits</li> </ul>	<ul style="list-style-type: none"> <li>- Ground settlement</li> </ul>
Sliding of side hill fills	<ul style="list-style-type: none"> <li>- Fills placed across hillsides</li> <li>- Inadequate sliding resistance</li> <li>- Water seeping out of hill or down slope is a major factor</li> </ul>	<ul style="list-style-type: none"> <li>- Transverse movement of track</li> </ul>

#### SUBSTRUCTURE INVESTIGATION

Being one of the most important steps in geotechnical engineering, a proper identification, classification and characterization of subgrade soils must be performed whenever an investigation of the substructure is carried out.

A limited substructure examination can be made by hand, or by machine through excavating inspection holes at the side of the track. Generally, these procedures are associated with relatively small practical limits for digging distance below the subgrade surface. Because conditions at the top part of the subgrade are often different beneath the track than at the side of the track, a better inspection can be made by removing the ballast shoulder. This allows inspection of the ballast and sub-ballast layers as well, which is usually needed whenever subgrade information is required.

The next level of investigation may involve excavating a cross trench from one side of the track to the other. This is important in fully evaluating the ballast, sub-ballast and upper subgrade conditions because conditions often vary with position across the track and with depth. In cases where subgrade depressions and ballast pockets occur, they might represent significant deviations from a plane boundary between layers that will not be known without a full (or at least half) width cross trench.

Depths of excavation to at least 1200 mm below the top of the sleeper can be done by using coring machines.

Identification of subgrade layers and materials to depths below those possible with coring machines or cross trenches require the use of standard drilling techniques. Common in situ geotechnical procedures include

- standard penetration tests (SPT)
- cone penetration tests (CPT)
- piezocone (CPTu)
- flat dilatometer (DMT)
- pressure meter (PMT)
- vane shear (VST).

Each test applies different loading schemes to measure the corresponding soil response in an attempt to evaluate its characteristics. Figure 4. 14 illustrates these various devices and simplified procedures in graphical form.

Boreholes are required for conducting SPT and normal versions of PMT and VST. A rotary drilling rig and crew are essential for these tests. In the case of the CPT, CPTu and DMT, boreholes are not needed. These are thus termed “direct-push” technologies. Specialised versions of the PMT (i.e. full displacement type) and VST can be conducted without boreholes. As such, these may be conducted using either standard drill rigs or mobile hydraulic systems in order to directly push the probes to the required test depths. A disadvantage of direct-push methods is that stiff tracked layers and bedrock will prevent further penetration. In such cases, borehole methods prevail as they may advance by coring or non-coring techniques.

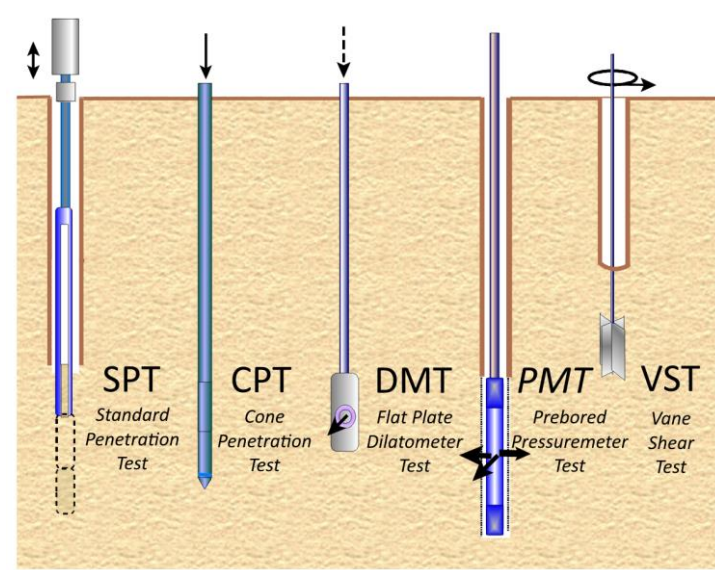

FIGURE 4.14 – COMMON IN-SITU TESTS FOR GEOTECHNICAL INVESTIGATION.

Physical properties of the layers can be measured in the field using in situ techniques, nevertheless direct measurement of properties such as the resilient modulus, plastic strain or strength characteristics require the elaboration of specific laboratory tests. Furthermore, for subgrade materials, undisturbed field samples will usually be required.

#### IDENTIFICATION OF DRAINAGE REHABILITATION NEEDS

Along with structural measures with the aim of strengthening the substructure, it is of great importance to assess the condition of the drainage system, its adequate design and the proper functioning of all its components. In this regard, locations where poor drainage might be the major cause for substructure weakening must be identified.

Excluding erosion by surface run-off, water generally causes the most problems after it infiltrates railway embankments and track substructures. Water in the soil and in cracks that have opened in the ground has the potential to destabilise embankments or decrease soil strength. It may also cause significant damage in frost-prone regions. This water is often a major contributor to track failures. Draining the track section and embankment is thus fundamental to improving track and embankment performance.

Water tends to accumulate in track locations where the drainage is impaired, such as railway crossing approaches, bridge approaches, low points in vertical curves, and at other locations where track settlement has occurred and the track has been raised on additional ballast. Typical places within an embankment where water may be expected to accumulate or become trapped include (IHHA, 2009):

- Ballast pockets;
- Cracks in embankments;
- The interface between the subgrade and a relatively stiff layer above (below ballast);
- At the contact of more permeable rock or soil with less permeable materials.

Interception and efficient drainage of non-track groundwater is another important aspect when assessing the performance of the existing drainage systems and their need for rehabilitation. Groundwater in soils below embankment, flowing toward embankment from upslope areas, or flowing toward track constructed in cuts can lead also to unstable track conditions. Interception and removal of this water and lowering of the groundwater table to a satisfactory depth below the embankment or track substructure may improve the performance of embankments and track sections (Figure 4.15). Collection and removal of this groundwater may also improve stability of the slope through which the water is flowing, whether located above or below the track.

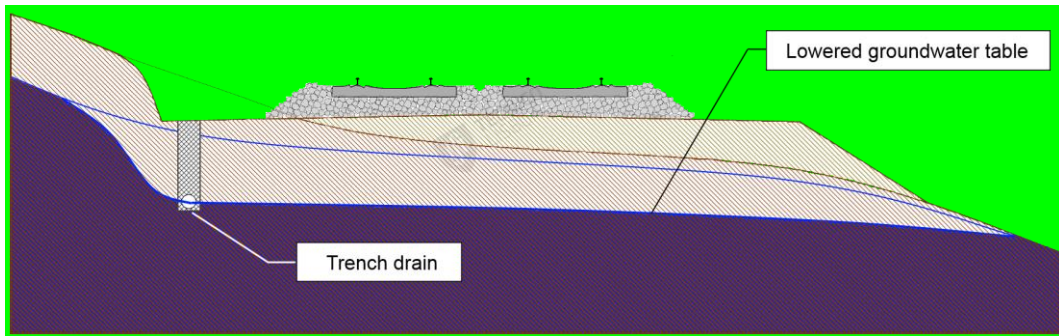

FIGURE 4. 15 – INTERCEPTION OF WATER INFLOW TROUGH TRENCH DRAIN.

The construction of trench drains (Figure 4.15) is a common solution to effectively intercept and drain near-surface groundwater flowing toward the track. These drainage components consist of an excavated trench backfilled with clean, well-graded gravel products that provide a high permeability path for water to escape from the embankment slope or subgrade. These drains may be constructed parallel to and relatively near the track, or at some distance upslope from the track. Shallow drains with pipes are sometimes installed parallel and near the track to improve subgrade performance.





Depending on the groundwater depth, topography and geology, other drainage systems may be required. Horizontal drains, small diameter perforated pipes installed in holes drilled into the ground are common alternatives. High groundwater conditions and springs also contribute to landslides. In a landslide susceptible terrain, trench drains, horizontal drains or other subsurface methods may be components of a landslide stabilization program.

A proper geotechnical investigation to the railway substructure and its surroundings might allow the identification of different indicators regarding groundwater conditions and inadequate functioning of drainage system components (Table 4.4).

TABLE 4.4 – INDICATORS OF HIGH GROUNDWATER CONDITIONS AND POOR DRAINAGE.

Indicators of inadequate drainage	
Wet ground near or on the embankment	



Indicators of inadequate drainage	
Ponded water adjacent to track	
Vegetation normally associated with wetlands growing on nearby slopes	
Water ponded in ditch and wetlands plants	
The presence of sinkholes on track or nearby slopes	

Collecting and diverting surface water away from the track structure may be the most cost-effective portion of any subgrade maintenance or rehabilitation program. The more water that is intercepted and diverted away from the track, the less water available to infiltrate and potentially weaken the track structure. Recommended practices, which must be part of a regular maintenance scheme and that should be carefully considered when assessing drainage rehabilitation needs in the scope of substructure upgrading include (IHHA, 2009):

- Improve surface drainage to make sure runoff runs off and does not pond;
- Divert surface water prior to it reaching problem area;
- Keep surface water at surface. Do not let it pond or infiltrate the embankment or ground upslope of the embankment;
- Deepen ditches below the bottom of the sub-ballast (do not deepen ditches excessively such that support is lost for the track section);
- Grade ditch bottoms to improve runoff;
- Clean ditches and culverts
- Check culverts and ensure they are in good condition, have not rusted through, and not pulled apart;
- Replace culverts that are too small with culverts of adequate capacity;
- Maintain culvert inlets and install systems to reduce potential for the inlet to plug or for debris to wash into the culvert and plug it;
- Remove from embankment shoulders any debris produced by maintenance activities such as undercutting, shoulder ballast cleaning and ditch cleaning;
- Grade shoulders to drain water over the side of the embankment without restricting the flow. Erosion protection measures may be required on the slope.

An effective drainage of shoulders and ditches contributes to a better drainage of the ballast and sub-ballast layers. Ballast drainage has to be maintained to keep the proper resiliency under the sleeper. This area is affected when there is not sufficient ballast under the sleepers. Train loading leads ballast to break down. The residue, along with dirt blown into the ballast section allows the ballast to become fouled. Fouled ballast and shoulder fouling lead to water retention in the track structure. As the crushing and grinding of ballast particles progresses, drainage from track structure is impaired. The water retained in the ballast because of this impaired drainage accelerates the ballast breakdown process. Ballast failure and the pumping associated with it may cause loss of sleeper support.

In summary, the presence of water weakens the substructure. Considerable experience is required to differentiate between causes of different types of failure and to select an appropriate remedial measure to correct the problem. No single remedy has been identified to correct all of these problems; but since most of these failure modes involve water, drainage improvement is usually part of the remedy. In some situations, remedial measures may lead to an acceptable solution. However, some remedial measures only provide a short-term solution by just treating the symptoms of the problems rather than analysing its root cause for longer term eradication. In these cases, the upgrading of the substructure must take into account that a full redesign of the drainage system might be necessary. An upgrading analysis should thus analyse available observations, measurements and the requirements for both the railway and its surroundings.

## 4.2 SUBGRADE IMPROVEMENTS

To mitigate poor subgrade conditions is often very costly. This includes not only the cost of material and work efforts, but also the commonly extensive traffic disruptions that are caused by the mitigating actions. There is thus a significant cost saving potential in developing new, LCC efficient improvement methods. However, these methods need also be thoroughly verified if they are to be employed in large-scale use. It is here important that not only the benefits, but also the drawbacks of each method are highlighted since the methods usually are suited mainly for certain conditions

In the INNOTRACK project, a number of improvement methods were investigated, tested and verified, see (Ekberg and Paulsson, 2010) and references therein. These were inclined piling using lime-cement columns, the use of geogrids in transition zones and bad drainage areas, and the use of short vertical soil-cement columns. These and other methods will be described in this section together with an outline of their benefits and shortcomings.

### 4.2.1 INTRODUCTION

Traditional open-cut improvement methods require the interruption of railway traffic for a long time. The different elements of the track used to be removed. Rails, sleepers, ballast, sub-ballast and often the embankment fill have to be withdrawn to perform the strengthening works. Apart from being time consuming, the traditional remedial works are costly in terms of material, resources and (often extensive) traffic disruptions. Figure 4.16 shows how the distribution of cost that can look like for an actual project of subgrade improvement with Deep Mixing Method (DMM).

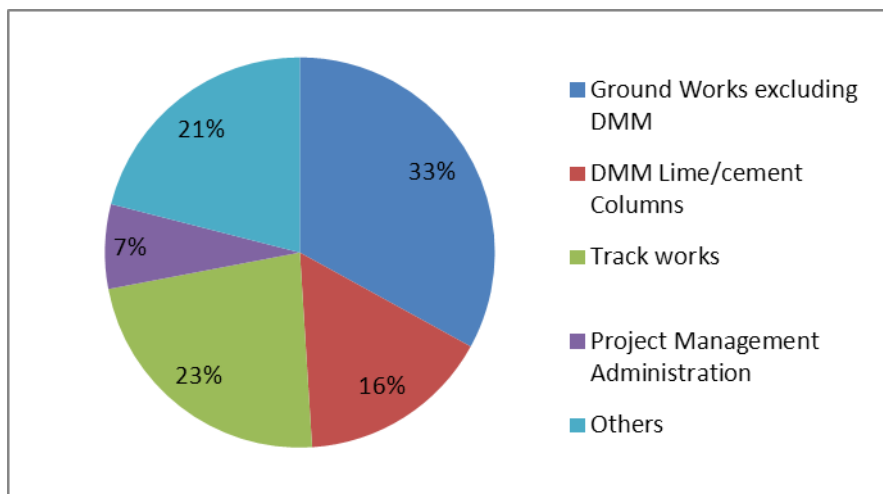

FIG. 4.16 - DISTRIBUTION IN A TYPICAL STRENGTHENING WORK WITH LIME/CEMENT COLUMNS INNOTRACK 2009

Figure 4.16 shows costs for strengthening works, not the costs due to traffic disruption. One can see that the cost for installation of lime/cement columns is only 16% of the total cost. In contrast, 56% of

the total cost is for ground and track works. It is therefore important to use soil improvement methods that minimize track work and reduce traffic disturbances.

There is thus a significant cost saving potential in developing new, LCC efficient improvement methods. However, these methods need also to be thoroughly verified if they are to be employed in large-scale use. It is here important that not only the benefits, but also the drawbacks of each method are highlighted since the methods usually are suited mainly for certain conditions.

Following this overview, there is a description of current practises in subgrade improvement, followed by some special use cases in the Northern and Southern countries of Europe, where the geotechnical conditions are significantly more difficult compared with the middle region.

#### 4.2.2 OVERVIEW OF STRENGTHENING METHODS

As mentioned before, there are many different methods available for subgrade improvement depending on the geotechnical conditions, allowed costs, construction time, performance, presence of buildings in the surroundings, tradition and experience of the contractor and the infrastructure manager, national regulations etc.

With the aim of selecting the correct method, it is first necessary to identify the problem to be solved. The most common problems in embankments are settlements, instability, and excessive vibrations. In all these cases increasing subsoil stiffness usually helps in solving the problem. There are two different approaches to obtain such an improvement: reinforcement inserted from the track, or from side of the railway embankment. Both methods have advantages and disadvantages.

#### SUBGRADE IMPROVEMENT FROM THE TRACK

Usually this type of work is carried out by equipment and tools mounted on railway vehicles. In most cases the works are done directly under the track. If the traffic should not be severely restrained, installation has to be carried out between sleepers. The space between two sleepers is 40 cm in the best case, which leads to the need for special tools. There are other restrictions such as the time available to conclude the installation. Traffic requirements usually reduce this time to a maintenance window.

Other considerations have to be taken into account. Catenaries, wires and poles represent especially dangerous elements in contact with the machines and tools needed for the installation. In addition, the methods that use bindings can pollute ballast during their installation. In this case, special tools have to be employed to keep the ballast clean.

**SUBGRADE IMPROVEMENT FROM SIDES OF RAILWAY EMBANKMENT**

Execution of subgrade improvement or installation of strengthening elements from the sides of the railway track is an easier way to deal with these kinds of works, especially on electrified lines. However, there is not in every case enough space next to the railway embankment, especially in urban areas.



All methods for soil improvement have impact on the track geometry during the installation. During the work it is important to assess the expected movements and the influence on the track, which typically has to allow train circulation at normal service speeds. When the line remains open to traffic during the execution, it is therefore recommended to use real-time automated methods to detect possible movements.

The impact of geotechnical issues is also very important and have to be taken account in the design phase. Characteristics of soil before, during and after strengthening must be assessed with consideration of time related changes. The design of the soil improvement has to assess the safety factor for the improved structure and for all stages of strengthening work. The risks of slide failure, subsidence and lateral movements have to be evaluated in advance and controlled during the execution of works.

Table 4.5 shows strengthening methods that have been used in the upgrading of railway subgrade. Of course, there are many other improvement techniques but these are less suitable for existing embankments. In addition, the table shows the influence on rail traffic and the kind of soils for which the method is applicable. It is noteworthy that, continuously, contractors develop new methods or adapt existing ones to their machines, local geotechnical conditions and railway related needs.

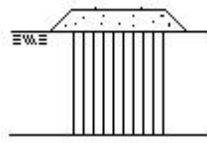
**TABLE 4.5. OVERVIEW OF EXISTING STRENGTHENING METHODS (SUSTAINABLE BRIDGES 2006) (INNOTRACK).**

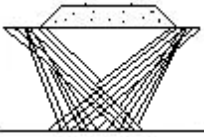
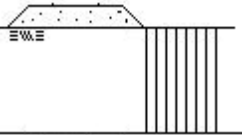
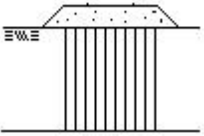
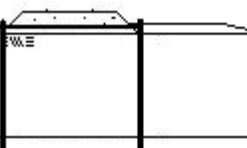
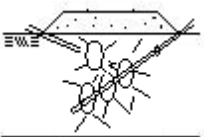
Scheme	Method	Principle	Can be performed without affecting traffic	Applicable soils	Increase of stability	Reduce settlements
	Deep mixing installed through the track and embankment	Mixes in-situ soils with cementitious materials to form a vertical stiff inclusion in the ground	No	Wet method: most soft soil Dry method: soft fine-grained soils	Yes	Yes

Scheme	Method	Principle	Can be performed without affecting traffic	Applicable soils	Increase of stability	Reduce settlements
	Deep mixing installed under embankment	Mixes in-situ with cementitious materials to form an inclined stiff inclusion in the ground	Yes	Wet method: most soft soil Dry method: soft fine-grained soils	Yes	Yes
	Deep mixing beside railway embankment	Mixes in-situ soils with cementitious materials to form a vertical stiff inclusion in the ground	Yes	Wet method: most soft soil types Dry method: soft fine-grained soils	Yes	No
	Jet grouting	Erodes soil in situ and mixes with cementitious materials to form stiff inclusion in the ground	Yes (unless installed beneath embankment)	Most soil types	Yes	Yes
	Stabilizing berms, alone or in combination with anchored walls	Compacted material constructed adjacent to embankment. Driven walls.	Yes	Clay	Yes	No
	Compaction grouting	Low slump grout is pumped into the ground, which displace and density the soil or fill voids in rock	Yes	Granular soil cavities	Yes	Yes
	Concrete slab on piles	Installation of piles on both sides of railway, precast slabs fixed on piles in short stages with traffic interruption	No	All soil types	Yes	Yes

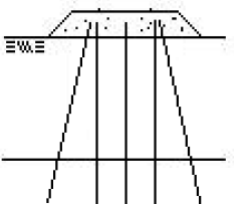
Scheme	Method	Principle	Can be performed without affecting traffic	Applicable soils	Increase of stability	Reduce settlements
	Soil nailing	Soil nails installation between sleepers	No	All soil types	Yes	No
	Vibro-compaction Vibro-replacement Vibro-concrete columns	Compaction of soil, transfer of loads to more competent strata through friction or end-bearing	No	Granular soils	Yes	Yes

#### 4.2.3 SUBGRADE IMPROVEMENT METHODS

##### DEEP MIXING METHOD

The Deep Mixing Method (DMM) was initially developed in 1970 in Japan (wet method) and Sweden (dry method) to stabilize subsoil under embankments. The deep mixing procedures increases the strength, lowers ductility, and lowers compressibility as compared to the original ground. The degree of improvement depends on the amount and type of stabilizer, installation process, characteristics of the original ground, and the curing time. This method can also be applied from the sides of the embankment, as shown in Figure 4.17.

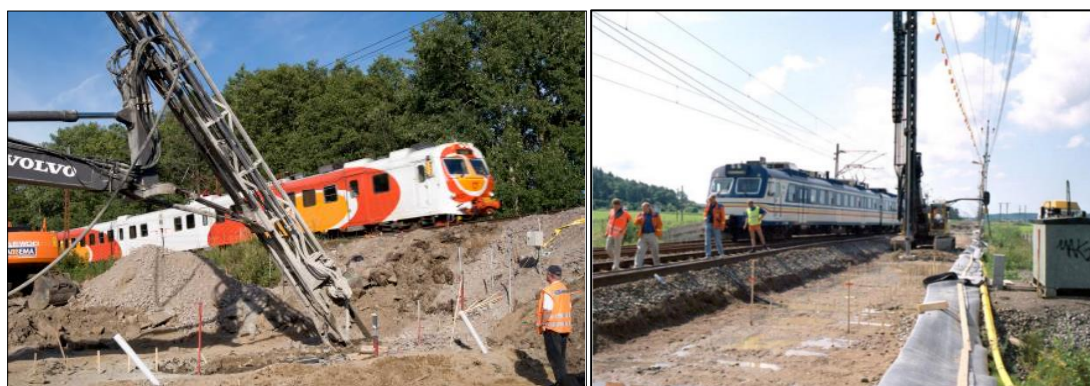
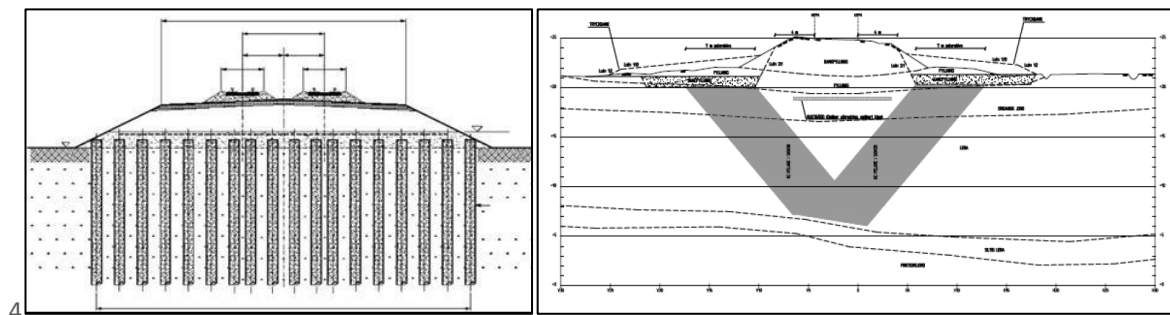

FIGURE 4.17 EXAMPLE OF INSTALLATION OF A LIME COLUMN. LEFT: INCLINED; RIGHT: VERTICAL (INNOTRACK, 2008)

The principle of this method is quite simple. In-situ soils are mixed with cementitious materials to form a stiff inclusion in the ground. A mixing tool is rotated down to the design depth, and once it is reached,

the direction of rotation of the mixing tool is reversed and the tool is withdrawn at a constant rate. During advancement and/or withdrawal of the mixing tool, agents such as quicklime, slaked lime, cement, and fly ash are forced into the ground. The deep mixing method produces columns in the ground that can be installed singularly, or in rows (walls), grids or blocks. When installed vertically the soft soil beneath the railway is stabilized. Vertical strengthening is normally used for newly constructed railways and there is an extensive experience based on experience and research with the application of deep mixed columns to support new railway embankments. Inclined lime cement columns for upgrading railway tracks have also been used, see (Ekberg and Paulsson, 2010) and references therein. Both cases can be seen in Figure 4.18.



**FIGURE 4. 18. DESIGN OF STRENGTHENING OF SUBSOIL USING VERTICAL OR INCLINED LIME-CEMENT COLUMN WALLS (INNOTRACK, 2008)**

This method requires the following steps in the design, execution and control:

1. Geotechnical survey and site investigations
2. Design of strengthening with lime cement columns
3. Quality control and safety plan for the installation
4. Analysis of possible restriction on train speed and axle load during installation
5. Preparation of construction site
6. Transport of machinery, tools and materials for lime cement columns
7. Site supervision during construction (Figure 4.19)
8. Follow up after installation of strengthening





FIGURE 4.19 POSITIONING OF LIME CEMENT COLUMNS

Table 4.6 shows the advantages and drawback of this method in the upgrading of existing railway infrastructures:

TABLE 4. 6. ADVANTAGES AND DRAWBACKS OF DEEP MIXING METHOD

Advantages	Drawbacks
<ul style="list-style-type: none"> <li>- Low vibrations during construction.</li> <li>- High attenuation of ground vibrations after installing.</li> <li>- High performance</li> <li>- Well known technology, with significant experience in new embankments (for vertical columns)</li> <li>- Technology available in most countries</li> <li>- Low impact on rail traffic (for inclined columns or vertical columns at the side of the track).</li> </ul>	<ul style="list-style-type: none"> <li>- Not much experience in upgrading railways (for inclined columns)</li> <li>- The need of heavy machinery could be a problem in very soft soils.</li> </ul>

### JET GROUTING

The jet grouting technology is very similar to the deep mixing technology except that very high-pressure fluids are used in jet grouting in order to erode subsurface soil particles and mix them with cement to form a solidified in situ element. Jet grouted elements can be installed in a variety of subsurface geometries. Columns with diameters of 0.6 to 2 m are common. Figure 4.20 shows a scheme of the installation of the jet grouting system and a picture of the flow ejected by the machine.

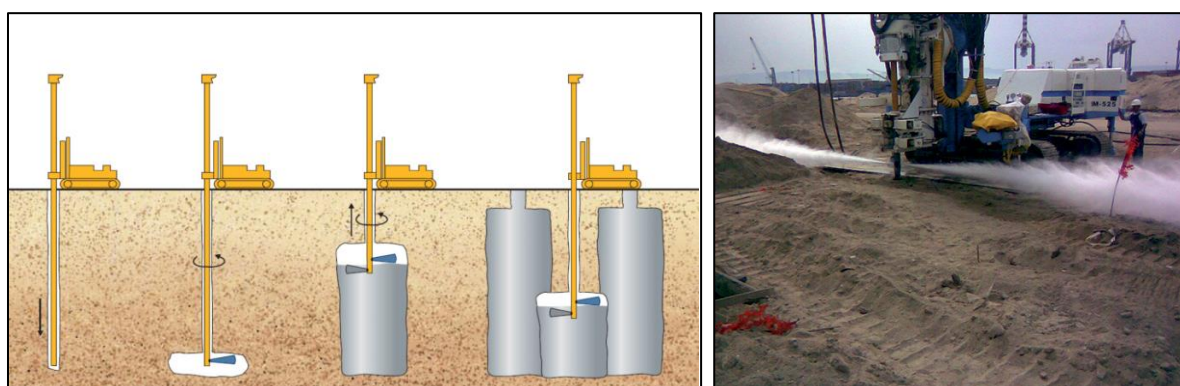

**FIGURE 4.20. SCHEME OF JET GROUTING INSTALLATION (LEFT). MACHINERY USED FOR CONSTRUCTION (RIGHT) (TRB, 2012)**

This system can be installed horizontally or vertically, or even at an angle. There are three traditional jet-grouting techniques:

- Single-fluid jet grouting uses high pressure (400 to 500 bar) grout only
- Double fluid-jet grouting uses high pressure grout sheathed in compressed air
- Triple-fluid jet grouting uses high-pressure water sheathed in air followed by a second jet of high-pressure grout.

The equipment to perform jet grouting remains specialized, but many contractors are available to carry out reinforcement using this technology. Drills range from relatively small electrically powered units up to the large crane supported systems. Some drills have the ability to create a wide variety of jet-grouted geometries. Theoretically, treatment depth is unlimited, but jet grouting has rarely been performed at depths below 50 m.

Table 4.7 shows the advantages and drawback of this method in the upgrading of existing railway infrastructures:

**TABLE 4.7. ADVANTAGES AND DRAWBACKS OF JET GROUTING**

Advantages	Drawbacks
<ul style="list-style-type: none"> <li>- Low vibration during construction.</li> <li>- Relatively small machinery, useful in small gauges.</li> <li>- Low surface settlements.</li> <li>- Suitable for many types of soil.</li> <li>- Different angles are possible for the columns.</li> <li>- Low impact on rail traffic (for inclined columns or installation at the side of the track).</li> </ul>	<ul style="list-style-type: none"> <li>- Not effective in very plastic clays.</li> <li>- Complex construction procedure.</li> <li>- Technology not always available.</li> </ul>

#### STABILIZING BERMS COMBINED WITH ANCHORED WALLS

- Stabilizing berms are often built adjacent to existing railway embankments to increase the bearing capacity of the embankment or to prevent instability. Stabilizing berms consist of a few meters of compacted material. Their thickness is about 1 to 2 metres. The use of loading berms is an effective way of increasing stability with costs that are quite low compared to other methods.
- However, this method presents some disadvantages that are necessary to consider. The main disadvantage of the stabilizing berms is that it does not reduce settlements or vibrations. In fact, the settlements of the railway embankment can even increase when loading berms are used (Ekberg and Paulsson, 2010). The predicted total and differential settlements need therefore be evaluated in advance.
- This negative effect can be reduced by combining the loading berms with walls installed along the railway embankment. Walls can be built for example as pile walls using concrete, steel, or wooden piles. Sheet piles as well as diaphragm walls have been used. Material used for supporting wall depends on the geotechnical conditions, the load and the geometrical situation of the particular project. On the other hand, it could be problematic to install driven elements, like for example sheet piles, through subsurface soils containing cobbles or boulders. In this case drilled or predrilled structures are more feasible.
- If the walls are installed on both sides of the railway embankment, anchors can be installed to connect the walls on opposing sides of the embankment. The anchors are post-tensioned to reduce horizontal movements in the walls. Figure 4.21 shows an example of a sheet pile wall used for stabilizing existing embankments.

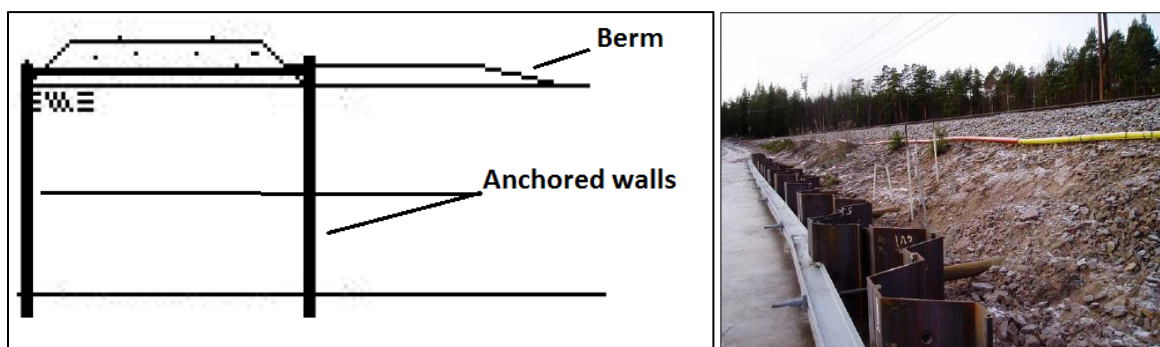

FIG.4.21. LEFT: SCHEME OF ANCHORED WALLS WITH STABILIZING BERM IN A RAILWAY EMBANKMENT; RIGHT: EXAMPLE IN VITMOSSEN (SWEDEN)

Table 4.8 shows the advantages and drawback of this method in the upgrading of existing railway infrastructures:

**TABLE 4.8 ADVANTAGES AND DRAWBACKS OF STABILIZING BERMS COMBINED WITH ANCHORED WALLS**

Advantages	Drawbacks
<ul style="list-style-type: none"> <li>- Low cost (if only stabilizing berm is used)</li> <li>- Low surface settlements (when using sheet pile walls).</li> <li>- Low impact on railway traffic</li> </ul>	<ul style="list-style-type: none"> <li>- High vibrations during installation of sheet piles.</li> <li>- Complex and expensive construction procedures when using anchors.</li> <li>- Only suitable for soft clays.</li> <li>- No reduction in settlements, only improvement of stability.</li> </ul>

#### COMPACTION GROUTING

The compaction grouting is a technology that injects a low slump grout into the ground to form a stiff, homogenous mass in the subsoil. The grout does not enter soil pores but remains in a stiff mass that gives controlled displacement in order to compact granular soils. The compaction grouting is commonly used to increase the density of soils. The grouted mass also adds vertical strength, since the grout compressive strength is much higher than that of native soil.

There are a number of applications of compaction grouting including remediation of embankment settlements, soil densification for site improvement, filling of voids in rock formation and liquefaction mitigation.

Compaction grouting is performed by injecting a very stiff grout through a casing at a high pump pressure; the casing is withdrawn incrementally and a column of interconnected grout bulbs is created. The grout is carried out through vertical or inclined grout pipes, see Figure 4.22.

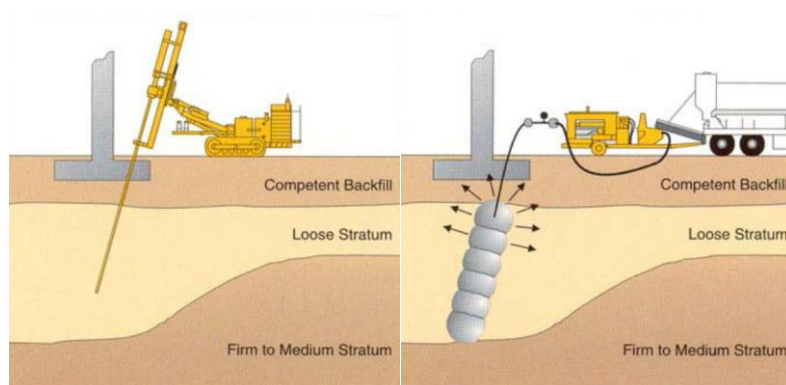

FIGURE 4.22. INSTALLATION PROCEDURE OF COMPACTION GROUTS BELOW A SHALLOW FOUNDATION (TRB, 2012)

Table 4.9 shows advantages and drawbacks of this method in the upgrading of existing railway infrastructures:

TABLE 4.9 ADVANTAGES AND DRAWBACKS OF COMPACTION GROUTING

Advantages	Drawbacks
<ul style="list-style-type: none"> <li>- Well known technology</li> <li>- Relatively small machinery, useful in small gauges.</li> <li>- Low impact on rail traffic.</li> </ul>	<ul style="list-style-type: none"> <li>- Only suitable for granular soils.</li> <li>- In cohesive soils, the injection can cause high excess of pore pressure, with later consolidation settlements.</li> <li>- No standardized procedure</li> <li>- Long-term behavior of the cement mortar is unknown.</li> </ul>

#### PRECAST CONCRETE SLAB ON PILES

The main advantage with this method is that the piles and longitudinal beams are installed on both sides of the existing railway without any disturbance of traffic. However, the pre-cast slabs are placed on piles after replacement of track in short traffic interruptions. This operation can be carried out during night and in this way minimizing rail traffic interruptions in the rush hours. Figure 4. 23 shows a scheme of this method.

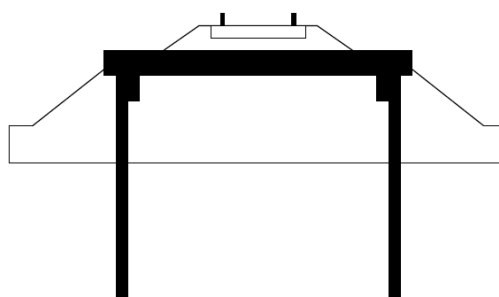

**FIGURE 4. 23. SCHEME OF PRECAST CONCRETE SLAB ON PILES**

Table 4. 10 shows advantages and drawbacks of this method in the upgrading of existing railway infrastructures:

**TABLE 4.10. ADVANTAGES AND DRAWBACKS OF PRECAST SLABS ON PILES**

Advantages	Drawbacks
<ul style="list-style-type: none"> <li>- Excellent control of settlements.</li> <li>- Suitable for all types of soils.</li> </ul>	<ul style="list-style-type: none"> <li>- Very expensive.</li> <li>- Low performance.</li> <li>- Moderate traffic disruption when installing the slabs.</li> <li>- Negative effects in the transmission of ground vibrations through the piles.</li> </ul>

### SOIL NAILING

Soil nailing is a strengthening technique that can be used to treat unstable natural soil slopes or as a construction technique that allows the safe over-steepening of new soil slopes. It can be also applied to existing railway embankments to prevent instability failures.

The technique consists in the insertion of relatively slender reinforcing elements into the slope, often general-purpose reinforcing rebar although proprietary solid or hollow-system bars are also available. Solid bars are usually installed into pre-drilled holes and then grouted into place using a separate grout line, whereas hollow bars may be drilled and grouted simultaneously by the use of a sacrificial drill bit and by pumping grout down the hollow bar as drilling progresses. Kinetic methods of firing relatively short bars into soil slopes have also been developed.

Bars installed using drilling techniques are usually fully grouted and installed at a slight downward inclination with bars installed at regularly spaced points across the slope face. Rigid facing or isolated soil nail head plates may be used at the surface. Alternatively, a flexible reinforcing mesh may be held against the soil face beneath the head plates. Rabbit proof wire mesh and environmental erosion control fabrics may be used in conjunction with flexible mesh facing where environmental conditions dictate.

The technique applied for strengthening of rail embankments is relatively cheap with high production in comparison to the other described methods. The technique can be applied from the track with minimal traffic disruption. Figure 4.24 shows an example of soil nailing driven from the track to the underground through the space between sleepers.

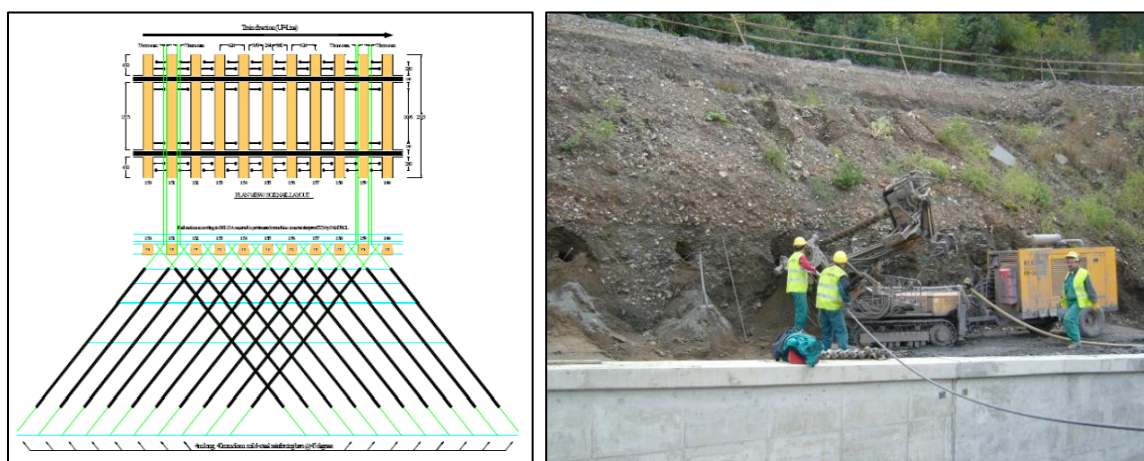

FIGURE 4.24. LEFT: AN EXAMPLE OF SOIL NAILING EXECUTED FROM THE TRACK (KONSTANTELIAS, 2003); RIGHT: STABILIZATION OF A RAILWAY EMBANKMENT WITH SOIL NAILING (INNTRACK, 2008)

Table 4.11 shows advantages and drawbacks of this method in the upgrading of existing railway infrastructures:

TABLE 4.11. ADVANTAGES AND DRAWBACKS OF SOIL NAILING METHOD

Advantages	Drawbacks
<ul style="list-style-type: none"> <li>- Low vibrations during construction.</li> <li>- High performance.</li> <li>- Good increase of stability.</li> <li>- Well known technology.</li> <li>- Low traffic disruptions.</li> <li>- Suitable to install from the track, between sleepers.</li> <li>- Relatively small machinery, useful in small gauges.</li> </ul>	<ul style="list-style-type: none"> <li>- No reduction in settlements, only improvement in stability.</li> <li>- Low depth of strengthening.</li> </ul>

### VIBRO-COMPACTION

This is a suitable method for densification of non-cohesive soils like sand, gravel or crushed rock. This method is based in the physical principle that vibration significantly reduces friction between soil grains and lets them rearrange to a denser structure. Subsequently, the pore volume is reduced and the stiffness increased.

Cylindrical depth vibrators generate vibration. The head of these vibrators carry unbalanced masses generating the vibration energy. Usually the vibrator penetrates to the designed depth and is then withdrawn in steps until the required compaction is achieved. During compaction, additional material has to be added since the volume decreases.

This method has to be applied carefully on in-service railway lines because the settlements of the track can be up to 15% of the treated volume. Additional ballast and sub-ballast as high-friction materials is recommended to be available for immediate levelling of the track.

Table 4.12 shows advantages and drawbacks of this method in the upgrading of existing railway infrastructures:

**TABLE 4.12. ADVANTAGES AND DRAWBACKS OF VIBRO-COMPACTION METHOD**

Advantages	Drawbacks
<ul style="list-style-type: none"> <li>- High performance.</li> <li>- Well known technology.</li> <li>- Low cost.</li> <li>- No materials such as cement, water, concrete or steel are necessary.</li> </ul>	<ul style="list-style-type: none"> <li>- High noise and vibration levels during construction.</li> <li>- Only suitable for granular soils.</li> <li>- Possible settlements during construction, which motivates line closure for safety reasons.</li> </ul>

### VIBRO-REPLACEMENT

This method is a combination of vibration and replacement of cohesive soils with granular material. The vibrator penetrates to a design depth and cavities are filled with coarse material (gravel, crushed stone or pebbles) which is then compacted by the vibrator. In this way, soft soils are improved with well-graded load bearing columns (Figure 4.25).

Usually a steel casing pipe is vibrated to the soil. When the pipe is withdrawn filling material is vibrated in, to create the stone or sand columns. Even a geotextile tube can be used to stabilize and improve performance of the columns. In this case, the method is called “Geotextile Coated Columns (GCC)”.

There are two variants of this method: “Dry bottom feed technique” which uses air pressure and “Wet bottom feed technique” which uses pressurized water. The dry bottom feed technique is more suitable for railway embankments due to the lower risk for large settlements and changes in stiffness below the track.

The risk for excessive settlements during the installation is lower than for vibro-compaction. Nevertheless, it is recommended to have additional ballast or sub-ballast ready in the case that levelling of the track is required.



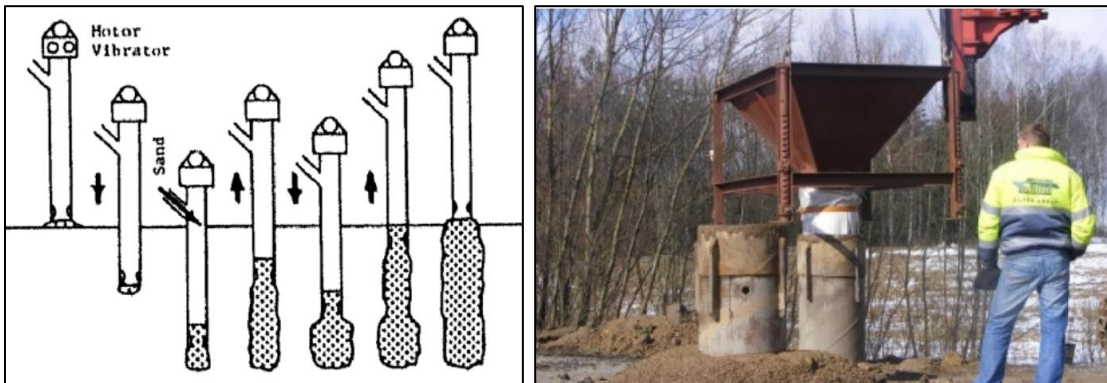

FIGURE 4.25 SCHEME OF VIBRO-REPLACEMENT PROCEDURE (LEFT) (TRB, 2012); INSTALLATION OF GEOTEXTILE COATED COLUMNS (RIGHT) (GEOSINTEX, 2012)

Table 4.13 shows advantages and drawbacks of this method in the upgrading of existing railway infrastructures.

TABLE 4.13. ADVANTAGES AND DRAWBACKS OF VIBRO-REPLACEMENT

Advantages	Drawbacks
<ul style="list-style-type: none"> <li>- High performance.</li> <li>- Low settlements during construction</li> <li>- Improvement of vertical drainage (pore pressure reduction).</li> <li>- Well known technology.</li> </ul>	<ul style="list-style-type: none"> <li>- Relatively high cost.</li> <li>- In case of GCC (patented), there are additional royalty costs.</li> <li>- High noise and vibration levels during construction.</li> <li>- Technology not always available.</li> <li>- Not much experiences in railways.</li> </ul>

### GRouted STone COLUMNS (GSC)

When using the vibro-replacement method in very soft clays or peat, the lateral support is usually not sufficient for adequate stabilization of columns. In the previous section, it was mentioned that the application of geotextile improves the lateral support. Another way to guarantee the stability of the hole is to use a cement grout suspension together with gravel during the installation process. Cement grout suspension forms together with the coarse material a stiff body of the column. Of course, such columns show much higher bearing capacity than those of the previously described methods.

Furthermore, the potential impact on the track during installation is lower but the time for hardening of the cement grout has to be considered before resuming normal train services.

Table 4.14 shows advantages and drawbacks of this method in the upgrading of existing railway infrastructures:

**TABLE 4.14. ADVANTAGES AND DRAWBACKS OF GROUTED STONE COLUMNS**

Advantages	Drawbacks
<ul style="list-style-type: none"> <li>- High performance.</li> <li>- Low settlements during construction compared to vibro-compacting.</li> <li>- Excellent bearing capacity.</li> </ul>	<ul style="list-style-type: none"> <li>- High cost.</li> <li>- High noise and vibration levels during construction.</li> <li>- Technology is not always available.</li> <li>- Not much experience in railways.</li> </ul>

### VIBRO-CONCRETE COLUMNS (VCC)

Pile-like bearing elements can be used for soils with very low bearing capacity, e.g. in an organic subsoil. These elements are inserted through the layers, which have a lower bearing capacity into the deeper and stiffer strata. In this case, after vibration the concrete is directly pumped from the bottom to the top of the column.

The earth structures above the concrete column can be reinforced horizontally with geotextiles (geogrids). This will improve the distribution of the pile loads and even out deformation. Under existing railways, the head of the columns can also be enlarged to obtain better support for sleepers. In these cases, it is recommended to place the column head deeper in the formation in order to avoid stress concentrations in the ballast.

This method can be applied from the sides of the embankment or to reinforce the foundation of civil structures, as shown in Figure 4.26.



**FIGURE 4.26. EXAMPLE OF VCC METHOD AT A RAILWAY BRIDGE**

Table 4.15 shows advantages and drawbacks of this method in the upgrading of existing railway infrastructures.

TABLE 4.15 ADVANTAGES AND DRAWBACKS OF GROUTED STONE COLUMNS

Advantages	Drawbacks
<ul style="list-style-type: none"> <li>- High performance.</li> <li>- Low settlements during construction compared to vibro-compacting.</li> <li>- Excellent bearing capacity achieved.</li> </ul>	<ul style="list-style-type: none"> <li>- High cost.</li> <li>- High noise and vibration levels during construction.</li> <li>- Technology is not always available.</li> <li>- Not much experience in railways.</li> </ul>

#### 4.2.4 OTHER METHODS FOR SUBGRADE IMPROVEMENT IN RAILWAY INFRASTRUCTURE

##### HYDRAULIC FRACTURING WITH INJECTION OF CEMENT GROUT (SPAIN)

This use case consisted in the consolidation and stabilization of an embankment located in the railway line Calatayud–Valencia, at the section between kilometres 208/100 and 208/200. The transit in the line includes passenger and freight trains. The passenger trains included the Euromed, which operates at 200 km/h. The problem of the embankment was due to low frequency vibrations transmitted by freight trains. This situation gave rise to sizeable deformations of the track, requiring very frequent tamping to correct the track geometry.

The adopted solution to this problem was the hydraulic fracture grouting technique through sleeve pipes (Figures 4.27 and 4.28). The work was carried out simultaneously with railway traffic operating at normal speed, while the substructure and the underlying embankment were being grouted down to a maximum depth of 7 m under strict requirements on keeping the track geometry (movements of rail less than 3 mm over a 5 m length).



FIGURE 4.27. DIFFERENT PHASES IN THE CONSTRUCTION (LOPEZ MORENO, 2013)

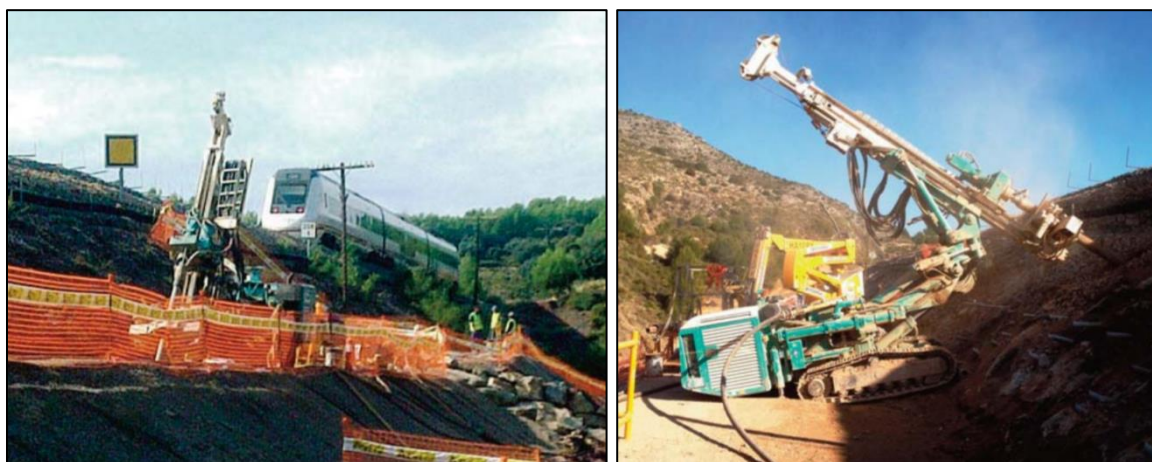

**FIGURE 4.28. EXECUTION OF INJECTIONS AT THE SIDE OF THE IN-SERVICE TRACK (LOPEZ MORENO, 2013)**

Other example of hydraulic fracture injection of stable cement-based mixed technique was carried out at the Southern embankment of the viaduct over the Ebro River, in the railway line Valencia–Barcelona of the Mediterranean Corridor (Oropesa–Vandellós line section), se Figure 4.29.

The basic objectives to achieve were:

- Increasing and regulating the modulus of deformation of the embankment, in the zones where it appeared less compact according to the results of the previous geophysical explorations. It was understood that the lack of compaction of those embankment zones had caused the need for ballasting the track in this section almost continuously.
- Making this soil improvement during normal service of the railway line.

To this end, it was essential to carry out improvement work from a platform independent of the railway line. This was achieved by building a berm adjoining the embankment and the transition zone.



**FIGURE 4.29. GENERAL VIEW OF THE EMBANKMENT WHERE THE SOIL IMPROVEMENT WAS ACHIEVED (EUROPEAN PROJECT SUPERTRACK, 2005)**

It was considered that the grouting technique, applied by means of sleeve tubes, could provide:

- The possibility of improving a predefined volume or body of embankment, by means of fans of sleeve tubes, installed from the working platform and oriented in such a way as to cover the grouting of that volume, taking into account the reach of the grout placed from every sleeve.
- The application, at each grouting sleeve, of the necessary number of passes of treatment until the grouting pressure, adequate for the degree of improvement envisaged at this location of the transition zone, would be reached.
- Use, at each grouting pass, of a grouting mixture of the necessary characteristics (viscosity, setting time, ...) placed at the convenient rate and volume, in order not to move the rails in excess of the comfortable circulation deformation limit (a criterion more exigent than the safe circulation deformation limit).
- A safe criterion to correlate the grouting pressure and the final parameters of shear strength in the treated soil so that the process of grouting could be properly controlled, and the end of the treatment at each sleeve clearly defined.



**FIGURE 4.30. GROUTING OPERATIONS (EUROPEAN PROJECT SUPERTRACK, 2005)**

This action, performed at the Southern embankment of the railway viaduct over the Ebro River in Amposta, see Figure 4.30, showed the feasibility of improving the condition of the transition zones without interference with the daily traffic passing during the improvement process.

It was verified that the modulus of deformation of the fill was increased by a factor of about 2.5, without exceeding the deformation limit for comfortable circulation on the track (3 mm maximum differential settlement between cross-sections 5 m apart).

The results obtained showed that the technique of hydraulic fracture by means of sleeve pipes might, if properly used, allow changing the conditions of any earth supporting structure of the track without

interfering with the commercial traffic and the track. Consequently, its use can be extended to any type of transition zone and supporting ground if necessary. Since the differential movements involved in the applications are less than 1/1000 this is applicable to railways, highways and buildings and structures, irrespective of their nature and the initial conditions.

#### INJECTIONS OF BENTONITE AND CEMENT MORTAR (SPAIN)

Another example of subgrade improvement in the rail embankment in Spain was the work carried out in the line Teruel–Sagunto (Figure 4.31). The degradation of some embankments in this line led to a limit on maximum speed to 30 km/h in several stretches ten years ago.

The process of strengthening was applied to embankment lengths of around 250 meters. In this case, a new technique based on injections of a special cement mortar with bentonite (a type of clay) was used.

This technique, as the example above, was applied from the sides of the embankment, avoiding traffic disruptions during the work.



FIGURE 4.31 TREATED RAILWAY SECTION (ESCUDERO, 2011)

#### INJECTIONS OF CEMENT MORTAR AND POLYURETHANE RESIN IN KARST (SPAIN)

In the high-speed line Madrid–Sevilla, next to the village of Yébenes, a karstified area in limestone was detected. In order to avoid a possible collapse of the track, cement mortar and polyurethane resin were injected in the cavities through boreholes drilled beside the track.

The improvement stretched up to seven meters below track. The work was carried out in maintenance windows, without affecting train services. During execution, the track geometry was controlled automatically to detect any movements.



FIGURE 4.32 RAILWAY SECTION TREATED (RODIO KRONSA, 1998)

#### 4.2.5 COMPARISON OF IMPROVEMENT METHODS



According to the previous descriptions, there are a number of advantages and drawbacks for each of the improvement methods. In order to facilitate the selection of the most suitable method from a technical point of view, table 4.16 shows a comparative assessment of six main characteristics:

1. Traffic allowance during execution
2. Type of soils where the method is applicable
3. Increase of stability against landslides
4. Effectiveness in the reduction of long-term settlements
5. Effectiveness in the reduction of vibration transmitted to neighboring buildings
6. Experience among European contractors and Infrastructure Managers.

The fulfillment of each criterion is graded high (green), medium (yellow) or low (red).

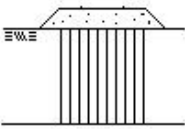
TABLE 4.16 COMPARED ADVANTAGES AND DRAWBACKS OF SOIL IMPROVEMENT METHODS

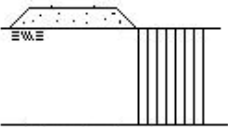
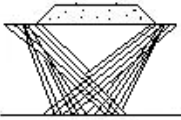
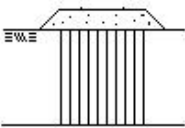
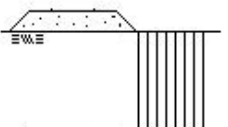
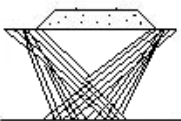
	Method	Scheme	ALLOW TRAFFIC	TYPE OF SOILS	INCREASE OF STABILITY	REDUCE SETTLEMENTS	REDUCE VIBRATIONS	EXPERIENCE
1	Deep mixing							

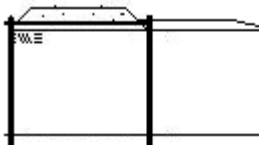
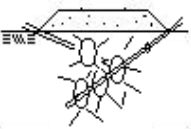
	Method	Scheme	ALLOW TRAFFIC	TYPE OF SOILS	INCREASE OF STABILITY	REDUCE SETTLEMENTS	REDUCE VIBRATIONS	EXPERIENCE
			Green	Orange	Green	Red	Orange	Green
			Green	Orange	Green	Orange	Orange	Green
2	Jet grouting		Red	Green	Green	Green	Orange	Green
			Green	Green	Green	Red	Orange	Green
			Green	Green	Green	Orange	Orange	Green
3	Stabilizing berms		Green	Orange	Green	Red	Red	Green
4	Stabilizing berms combined with anchored walls		Red	Orange	Green	Red	Red	Red
5	Compaction grouting		Green	Red	Orange	Orange	Red	Green

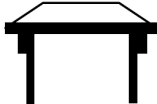
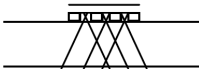
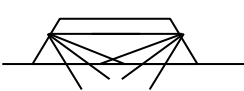
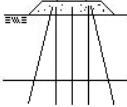
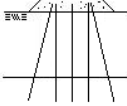
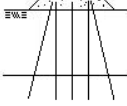
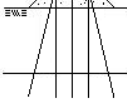

	Method	Scheme	ALLOW TRAFFIC	TYPE OF SOILS	INCREASE OF STABILITY	REDUCE SETTLEMENTS	REDUCE VIBRATIONS	EXPERIENCE
6	Precast concrete slab on piles		Red	Green	Green	Green	Red	Red
7	Soil nailing		Red	Green	Green	Red	Red	Orange
			Green	Green	Green	Red	Red	Orange
8	Vibro-compaction		Red	Red	Green	Orange	Red	Green
9	Vibro-replacement		Red	Orange	Green	Green	Red	Green
10	Grouted stone columns		Red	Orange	Green	Green	Red	Orange
11	Vibro-concrete columns		Red	Orange	Green	Green	Red	Red

## REFERENCES

Aknin, P. and Chollet, H. (1997): A new approach for the modelling of track geometry recording vehicles and the deconvolution of vesine measurements, Vehicle System Dynamics Supplement 33.

Andersson, A., Berglund, H., Blomberg, J. and Yman, O. (2013): The Influence of Stiffness Variations in Railway Tracks. Bachelor Thesis in Civil Engineering, Chalmers University of Technology, Gothenburg, Sweden.

Berggren, E. G. (2005): Dynamic Track Stiffness Measurement – A New Tool for Condition Monitoring of Track Substructure, Licentiate thesis TRITA AVE 2005:14, Royal Institute of Technology (KTH), Stockholm.

Berggren, E. G. (2009): Railway Track Stiffness – Dynamic Measurements and Evaluation for Efficient Maintenance. PhD Dissertation, Royal Institute of Technology, Stockholm, Sweden.

Berggren, E., Jahlénus, A., Bengtsson, B. E. and Berg, M. (2005): Simulation, Development and Field Testing of a Track Stiffness Measurement Vehicle, Presentation and in the proceedings of 8<sup>th</sup> International Heavy Haul Conference, Rio de Janeiro, 13-16 June 2005.

Bold, R. De. (2011): Non-Destructive Evaluation of Railway Trackbed Ballast. PhD Dissertation, Institute for Infrastructure and Environment, School of Engineering, University of Edinburgh, Edinburgh, Scotland. Retrieved from <http://www.era.lib.ed.ac.uk/handle/1842/5027>

Burrow, M. P. N., Teixeira, P. F., Dahlberg, T. and Berggren, E. G. (2009): Track Stiffness Considerations for High Speed Railway Lines. (N. P. Scott, Ed.) Railway Transportation: Policies, Technology and Perspectives (pp. 1–55). Nova Science Publishers. Retrieved from <http://www.diva-portal.org/smash/record.jsf?pid=diva2:264566>

Crawford, S., Murray, M. and Powell, J. (2001): Development of a Mechanistic Model for the Determination of Track Modulus. In Proceedings of 7<sup>th</sup> World Congress on Railway Research. Brisbane, Australia. Retrieved from <http://eprints.qut.edu.au/2599/>

Dahlberg, T. (2003): Railway Track Settlements – A Literature Review. Report for the EU Project SUPERTRACK. Retrieved from <http://www-classes.usc.edu/engr/ce/599/Thesis/RTRSETTL.pdf>

Ebersöhn, W. and Selig, E. T. (1994): Track Modulus Measurements on a Heavy Haul Line, Transportation Research Record 1470, TRB, National Research Council, Washington D.C.

Ekberg, A. and Paulsson, B (eds) (2010): INNOTRACK – Concluding Technical Report, International Union of Railways (UIC), ISBN 978-2-7461-1850-8

Esveld, C. (2001): Modern Railway Track (2nd Ed.). Zaltbommel: MRT-Productions.

Grainger, P. S., Sharpe, P. and Collop, A. C. (2001): Predicting the Effect of Stiffness on Track Quality, Proceedings from Railway Engineering Conference, London.

Hildebrand (2001): Countermeasures against Railway Ground and Track Vibrations, PhD Dissertation, Royal Institute of Technology (KTH), Stockholm.

Hosseingholian, M., Froumentin, M., Levacher, D. (2009): Continuous Method to Measure Track Stiffness A New Tool for Inspection of Rail Infrastructure. *World Applied Sciences Journal*, 6(5), 579–589. Retrieved from [http://www.idosi.org/wasj/wasj6\(5\)/1.pdf](http://www.idosi.org/wasj/wasj6(5)/1.pdf)

Hunt, G. A. and Wood, J. (2005): "Review of the effect of track stiffness on track performance, Research Project T372, Rail Safety & Standards Board.

Innotrack (2010): Innotrack – Innovative Track systems. A European FP6 Integrated Research Project during 2006-2010.

Iwnicki, S. (Ed.). (2006): *Handbook of Railway Vehicle Dynamics*. Boca Raton, Florida: CRC Press.

Jones, C. J. C. and Thompson, D. J. (2001): Means of Controlling Rolling Noise at Source, Ch. 6 from *Noise and Vibration from High-Speed Trains*, Editor V. Krylov, Thomas Telford Ltd.

Köhler, J. (1999): Track Loading Vehicle – Description, Internal report: Banverket BMA 98/22k, Borlänge.

Li, D. and Selig, E. T. (1995): Evaluation of Railway Subgrade Problems, *Transportation Research Record* 1489, TRB, National Research Council, Washington D.C.

Li, D., Thompson, R. and Kalay, S. (2002): Development of Continuous Lateral and Vertical Track Stiffness Measurement Techniques, *Proceedings from Railway Engineering Conference*, London.

Li, M. X. D. and Berggren, E. G. (2010): A Study of the Effect of Global Track Stiffness and Its Variations on Track Performance: Simulation and Measurement. *Proceedings of the Institution of Mechanical Engineers, Part F: Journal of Rail and Rapid Transit*, 224, 375–382. doi:10.1243/09544097JRRT361

López-Pita and Teixeira, P. F. (2001): Resistant Track Homogeneity: A Way to Reduce Maintenance Costs, *Proceedings from Railway Engineering Conference*, London.

López-Pita and Teixeira, P. F. (2002): Influence of Ballast Density on Track Deformation, *Proceedings from Railway Engineering Conference*, London.

López-Pita, A. and Teixeira, P. F. and Robusté, F. (2004): "High speed and track deterioration: The role of vertical stiffness of the track." *Proceedings of the Institution of Mechanical Engineers, Part F: Journal of Rail and Rapid Transit* 218(1): 31-40.

Lundqvist, A. (2005): Dynamic train/track interaction – Hanging sleepers, track stiffness variations and track settlements, *Licentiate Thesis*, LIU-TEK-LIC 2005:14, Linköping University.

McVey, B., Norman, C. and Wood, N. (2005): Track Modulus Measurement from a Moving Railcar. In *Proceedings of the AREMA 2005 Conferences* (pp. 1–25). 25-28 September, Chicago, Illinois, USA. Retrieved from [http://www.engineering.unl.edu/research/robots/publicationdocs/AREMA\\_2005\\_B\\_McVey.pdf](http://www.engineering.unl.edu/research/robots/publicationdocs/AREMA_2005_B_McVey.pdf)

Öberg, Johan (2006): Track Deterioration of Ballasted Tracks: Marginal cost models for different railway vehicles, M. Sc. Thesis, Rail Vehicles, Aeronautical and Vehicle Engineering, Royal Institute of Technology, 102 pp.

Prud'Homme, A. (1970). La voie. Revue Generale des Chemins de Fer, January 1970, 1, 56-72.

Puzavac, L., Popovic, Z. and Lazarevic, L. (2012): Influence of Track Stiffness on Track Behaviour Under Vertical Load. Promet - Traffic & Transportation, 24(5), 405–412. Retrieved from <http://www.fpz.unizg.hr/traffic/index.php/PROMTT/article/view/1176>

Read, D., Chrismer, S., Ebersöhn, W. and Selig, E. T. (1994): Track Modulus Measurements at the Pueblo Soft Subgrade Site, Transportation Research Record 1470, TRB, National Research Council, Washington D.C.

Selig, E. T. (1997): Substructure Maintenance Management, Proceedings from 6th IHHA Conference, Cape Town 1997.

Selig, E. T. and Li, D. (1994): Track Modulus: Its Meaning and Factors Influencing It. Transportation Research Record, 1470, 47–54.

Selig, E. T. and Waters, J. (1994): "Track Geotechnology and Substructure Management." London, ICE Publishing.

Selig, E. T., Hyslip, J. P., Olhoeft, G. R., and Smith, S. (2003): "Ground penetrating radar for track substructure condition assessment". Proc. Of Implementation of Heavy Haul Technology for Network Efficiency, Dallas, TX, May, p. 6.27-6.33.

Selig, E.T.: Railway Track Design. Handbook of Transportation Engineering (2004)

Shein, A., Chan, A. H. C. and Burrow, M. P. N. (2007): Deflectometer-based Analysis of Ballasted

Smartrail (2014): Smartrail - Smart Maintenance Analysis and Remediation of RAIL infrastructure. A European FP7 Project 2011-2014 with 15 partners, see <http://smartrail.fehrl.org/?m=1> (Accessed 2014-09-09)

Smekal, A., Berggren, E. and Hrubec K. (2003): Track Substructure Investigations using Ground Penetrating Radar and Track Loading Vehicle, Proceedings from Railway Engineering Conference, London.

Suiker, A. S. J. and Esveld, C. (1997): Stiffness Transition Subjected to Instantaneous Moving Load Passages, Proceedings from 6th International Heavy Haul Conference, Cape Town.

Sussmann, T. R., Ebersöhn, W. and Selig, E. T. (2001): Fundamental Nonlinear Track Load Deflection Behavior for Condition Evaluation, Transportation Research Record 1742, Paper No. 01-2916.

TecRec 200-001 (2013): Technical Recommendation Rail, Reprofilng Management, 2013. Published but not approved since TecRecs was withdrawn.

Teixeira, P. F. (2003): Contribución a la Reducción de los Costes de Mantenimiento de Vías de Alta Velocidad Mediante la Optimización de su Rigidez Vertical. PhD Dissertation, Escola Tècnica Superior d'Enginyers de Camins, Canals i Ports de Barcelona, Polytechnic University of Catalonia, Barcelona, Spain

Öberg, Johan (2006): Track Deterioration of Ballasted Tracks: Marginal cost models for different railway vehicles, M. Sc. Thesis, Rail Vehicles, Aeronautical and Vehicle Engineering, Royal Institute of Technology, 102 pp.

### 4.3 MITIGATING GROUND VIBRATIONS

Several new traffic situations can imply an increase of ground vibration levels. Therefore, it is important to have a high understanding of ground vibrations. The topic of ground vibrations and how these should be mitigated has been the focus of the EU-project RIVAS – Railway Induced Vibration Abatement Solutions (see <http://www.rivas-project.eu> ). A good and easy to read summary is presented in the final newsletter, see (UIC, 2013). For more in-depth information, the RIVAS project has authored a number of guidelines to aid in vibration reduction see references.

#### 4.3.1 METHODOLOGY

RIVAS investigated a number of preventive and mitigating actions. To quantify the efficiency of these, vibration levels were measured in a test section and in a reference section at a certain distance from the track before and after the installation of the mitigation measure. In addition, an analysis of vehicle, track and soil parameters that significantly influence vibration levels was carried out. To assess the annoyance inside buildings four descriptors (two vibration-related and two vibration-induced noise related) were employed. The annoyance reduction was then presented with respect to the cost–benefit ratio.

The proposed methodology proved to be an efficient means of identifying the potential of different mitigating actions. One important finding was however that the measured efficiency depends significantly on the pre-load of the track.

#### 4.3.2 GENERATION OF VIBRATIONS

Regarding the generation of vibrations in the wheel–rail interface, it was shown that wheel out-of-roundness (and in particular local tread defects such as wheel flats) could have a strong influence on the vibrations emitted by some categories of rolling stock. Track geometry defects with wavelengths shorter than some 10 m have some influence on the low frequency vibration, but the parametric

excitation due to sleeper passing has to be considered in addition. Isolated defects shorter than 3 m may generate significantly high free-field vibrations. Finally, dipped rails at welds and insulated rail joints can generate high wheel–rail impact loads with broad frequency contents that lead to high vibration levels.

In summary, the analyses in RIVAS concluded that regarding track defects longitudinal level misalignments with wavelengths of 0.6 m seem to have the highest overall vibration impact, although the highest vibration levels are found near welds and insulation joints. Regarding wheels, out-of-roundness is the main influencing factor. To capture the essential track geometry characteristics, RIVAS proposed to introduce a new wavelength band containing wavelengths in the interval 0.5 – 3 m for the assessment of track geometry measurements.

Regarding vehicle characteristics, the influences of the car-body mass and the bogie mass are small on vibration that propagates to larger distances from the track. The secondary suspension comes into play at very low frequencies where other generation mechanisms related to the soil often are dominant. The primary suspension stiffness and in particular the unsprung mass are the two vehicle parameters that have the most significant influences on the vibration level. As an indication of the efficiency of mitigating actions, simulations estimated reductions in nearby houses to some 2–3 dB owing to a reduction of unsprung mass by 35%.

More information can be obtained from the RIVAS guideline D5.5.

#### 4.3.3 TRACK-BASED MITIGATION

As for track-based mitigation, RIVAS evaluated the following measures:

- Soft under sleeper pads coupled with heavy (wide) sleepers optimized for straight ballasted tracks
- Soft rail pads optimized for straight ballasted tracks
- Soft under sleeper pads in curves
- Soft under sleeper pads in switches
- Soft under sleeper pads optimized for the GETRAC slab track system

It was found that ground stiffness has a minor impact on the efficiency of both under sleeper pads and rail pads for sleeper systems.

Simulations indicated that sleeper pads on slab would reduce ground-borne noise, but increase vibrations.

More information can be obtained from the RIVAS guideline D3.13.

#### 4.3.4 TRANSMISSION REDUCTIONS

Studied mitigating actions include installation of trenches, buried wall barriers, subgrade stiffening, horizontally layered wave-impeding blocks, and heavy masses at the soil surface. Since the layered ground structure has a significant influence on the response, all options were studied numerically for different ground types to establish the circumstances in which they are efficient. In addition, three field tests were carried out: soil stiffening next to the track, a trench barrier, and a sheet piling wall.

As an example of results, a sheet-piling wall in Furet (Sweden) with a length of 100 m and a depth of 12 m with every fourth pile extended to 18 m was installed. Measurements showed that maximum vibration levels are reduced by about 50% close to the wall. At 32 m from the centre the maximum levels are reduced by about 30% while at 64 m from track centre, no reduction in maximum vibration levels is seen. The sheet pile wall did not lead to any increase in vibration levels at the other side of the track.

A soft wave barrier, 6 m deep, 5 cm wide located at 8 m from the track also resulted in reduction of vibrations and ground-borne noise in three nearby buildings. The reductions varied between some 2 dB to some 15 dB depending on building and descriptor used.

The analysis further revealed the usefulness of numerical simulations in evaluating different solutions. In addition, the levels of reduction were found to be significantly influenced by ground characteristics. More information can be found in the RIVAS guideline D4.6.

#### REFERENCES

---

Dorothee Stiebel, Final evaluation of results, RIVAS Final Conference, November 21, 2013

UIC, RIVAS Vibrations: Ways out of the annoyance, 28 pp, 2013

E. Bongini, R. Müller, R. Garburg and A. Pieringer, D3.13 – Guidelines for mitigation measures on ballasted track, curves, switches and slab track, 32 pp (and 3 annexes 6+8+4 pp), 2013

G. Lombaert, A. Dijckmans, P. Coulier, G. Degrande, A. Smekal, A. Ekblad, D.J. Thompson, J. Jiang, M.G.R. Toward, W. Rücker, J. Keil, G. Vukotic, M. Rodríguez Plaza, Á. Andrés, V. Cuéllar, R. Garburg and R. Müller, D4.6 – Design guide and technology assessment of the transmission mitigation measures, 30 pp (and 4 annexes 4+3+3+2 pp), 2013

Jens Nielsen, Adam Mirza, Philipp Ruest, Philipp Huber, Steven Cervello, Roger Müller and Brice Nelain, D5.5 – Guideline for design of vehicles generating reduced ground vibration, 43 pp (and 1 annex 3 pp), 2013

These reports can be downloaded from the RIVAS website ( <http://www.rivas-project.eu> )

---

## 5. Bridges

---

### 5.1 GENERAL

#### 5.1.1. CODES FOR NEW AND EXISTING BRIDGES – SAFETY REQUIREMENTS

Today's codes are written for the design of new structures, e.g. the Eurocodes, EC0 – EC9 (2000-2009). An interesting account of the obstacles encountered in their development is given by (Johnson, 2009) who was involved in the first 40 years of the creation of the codes. Now work is going on to implement, revise and harmonize them, see e.g. (EC Handbook 1-4 (2004, 2005) and JRC Bridge Examples, (2012).

When building a new structure there are uncertainties regarding geometry, material properties, construction quality and loads. These uncertainties can be balanced by a reasonable safety margin in partial coefficients ( $\gamma$ ), special load factors for railways ( $\alpha$ ) and reliability indices ( $\beta$ ). The partial coefficients are safety factors used for loads and material properties, the  $\alpha$ -factor adjusts for rail traffic that is heavier or lighter than normal traffic and the reliability indices indicate the internationally accepted probability of failure. The ( $\alpha$ -factor) is used to meet future needs (see chapter 1 Background). Typical partial coefficients in the Eurocodes for permanent loads are  $\gamma_G = 1.35$  and for live loads  $\gamma_Q = 1.50$ . For structural material properties, typical values of the partial coefficients are  $\gamma_c = 1.50$  for concrete and  $\gamma_s = 1.10$  for structural steel, see e.g. (EC Handbook 1, 2004). The rail traffic  $\alpha$ -factors may vary between 0.75 and 1.46 with  $\alpha = 1.33$  recommended on lines for freight traffic and international lines, (UIC 702, 2003). A probability of failure of 1 in 100 hundred,  $P_f = 0.01$ , corresponds to a reliability index  $\beta = 2.3$ , a probability  $P_f = 10^{-5}$  corresponds to  $\beta = 4.2$ , a probability  $P_f = 10^{-6}$  corresponds to  $\beta = 4.7$  and a probability  $P_f = 10^{-7}$  corresponds to  $\beta = 5.2$  see e.g. EC Handbook 2 (2005) and (Schneider and Vrouwenvelder, 2017).

The Eurocodes indicate target reliability indices in relation to three classes of consequences (high, normal and low) and two reference periods  $T$  (1 and 50 years). For a failure with low consequences (e.g. a greenhouse) during a period of  $T = 50$  years the recommended reliability index is  $\beta = 3.3$  corresponding to a failure probability of  $P_f = 0.0005$  (5 in 10 000). For a failure with high consequences (e.g. a bridge) during a period of  $T = 1$  year the recommended reliability index is  $\beta = 5.2$  corresponding to a failure probability of  $P_f = 10^{-7}$  (1 in 10 million). If the period is increased to  $T=100$  years, this increases the failure probability to  $P_f = 10^{-5}$  (1 in 100 000) with  $\beta = 4.2$ .

As a comparison, the risk of death for a person during one year varies with where the person is living and what he/she is occupied with and it changes during the lifetime. As an example, in Sweden the death probability during one year ( $T=1$ ) for a 1 year old child is  $P_f = 0.00012$  (1.2 in 10000); for a 40 year old person it is  $P_f = 0,001$  (1 in 1000); for a 60 year old person it is  $P_f = 0.01$  (1 in 100); and for a 100 year old person it is  $P_f = 0.36$  (1 in 3). The death rate due to accidents and suicide is about  $P_f = 0.001$ , according to SCB (2007). The acceptable individual risk of death during a year due to an accident caused by a structural failure is in JRC Assessment (2015) proposed to be  $P_f = 10^{-5}$  which is about 1 % of the general risk for death due to accident and suicide given above for Sweden.



When assessing the capacity of an existing structure many of the uncertainties that are present when building a new structure can be resolved. The codes for assessment therefore do not need to have the same high partial coefficients  $\gamma$ ,  $\alpha$ -factors or reliability indices  $\beta$ , see e.g. SB-LRF (2007), ML-D1.2 (2013) and JRC Assessment (2015). In addition, standard dynamic amplification factors for the influence of dynamic loads may be reduced after a study of a structure. Thus, there is a need for special codes for upgrading of existing structures.

An early example of such codes was the Swedish BV Bärighet, (1996). The code has been updated several times and is presently divided in two parts, one with requirements TRVK Bärighet, (2014) and one with recommendations TRVR Bärighet, (2014).

One example of a new set of standards for assessment of existing structures is the Swiss code (SIA 269/1/2/3, 2011). (Brühwiler, 2014 and 2015) gives a description of the positive experiences with it. He highlights major principles and approaches, in particular those related to a stepwise procedure, see Figure 5.1, and by updating of action effects through monitoring, updating of structural resistance and novel technologies of intervention, such as strengthening. It is often beneficial to use site-specific live loads and dynamic amplification factors, see e.g. ML-D1.4 (2012) and (Casas and Rodrigues, 2015). In the Swiss codes the recommended reliability index for a reference period of  $T = 1$  year varies from  $\beta_{27} = 3.1$  for a minor consequence of a failure to  $\beta = 4.7$  for a serious consequence, see JRC Assessment (2015). This is lower than the factor  $\beta = 5.2$  given above for new bridges.

In France, partial safety factors have been studied for different variables, such as reinforcement area, yield strength, concrete density and fixed load moment. For road bridges, the allowable reliability index could in some case be lowered with 7 % compared with the target reliability index, (Cremona, 2014).

Work has also started on a Eurocode for assessment of existing structures; see JRC Assessment (2015).

### 5.1.2. INFLUENCE OF NEW TRAFFIC SITUATIONS

For bridges the highest impact comes from increased axle loads and meter loads. Longer trains and increased train weights have some impact, whereas higher speeds on freight trains has little impact and increased loading gauges usually has no impact.

In order to successfully adjust existing structures to new traffic situations, codes and assessment methods have a vital importance. General principles will be commented on below before presenting specific conditions for different types of structures.

The fatigue capacity for steel and reinforcement will usually decrease with shorter life lengths as a result. Examples are given in Section 9.1.2 and Figure 9.2 for tracks but the phenomenon is valid for all metallic materials.

### 5.1.3. INFLUENCE ON MAINTENANCE ROUTINES

Instead of continuing the orders of static maintenance schedules and of break-fix work, new methods for proactive, preventive and predictive maintenance routines are being introduced.

Proactive maintenance is the maintenance philosophy that supplants “failure reactive” with “failure proactive” by activities that avoid the underlying conditions that lead to faults and degradation. Unlike predictive or preventive maintenance, proactive maintenance commissions corrective actions aim at failure root causes, not failure symptoms. Its central theme is to extend the life of assets as opposed to (1) making repairs when often nothing is wrong, (2) accommodating failure as routine or normal, or (3) detecting impending failure conditions followed by remediation. Proactive maintenance depends on rigorous inspection and condition monitoring. In bridges it seeks to detect and eradicate failure root causes such as corrosion and fatigue. It may use remote condition monitoring and BIM (Building Information Modelling), (Ricketts, 2017).

## 5.2 WORK PROCESS – ASSESSMENT AND STRENGTHENING OF EXISTING BRIDGES.

In Figure 5.1 below, an assessment is divided into three phases: Initial, Intermediate and Enhanced. The initial first phase includes a site visit, study of documentation and simple calculations. The intermediate second phase may include material investigations, detailed calculations and/or analyses and further inspections and monitoring. The enhanced third phase usually consists of refined calculations and analyses including statistical modelling and reliability based assessments, laboratory examinations and/or field-testing and economic decision analysis. Similar well-structured procedures are proposed in (Schneider, 1994), ISO 13822 (2010) and JRC Assessment (2015). An enhanced assessment is often the most cost-effective way to increase the allowable load, as there is in most cases a considerable hidden bearing reserve in existing bridges and culverts.

The value of a structured approach will be illustrated with examples below. Hidden bearing capacities have also been proven by full-scale tests of bridges to collapse, see e.g. (Puurula et al, 2015). In addition, there are many examples of successful strengthening of bridges that have provided the extra capacity needed to fulfil a new traffic situation, ML-D1.4 (2015), (Nilimaa, 2015). General information on upgrading and strengthening of structures is given in e.g. the guidelines and background documents from the European projects Sustainable Bridges (2007) and MAINLINE (2014), see also (Paulsson et al, 2016).

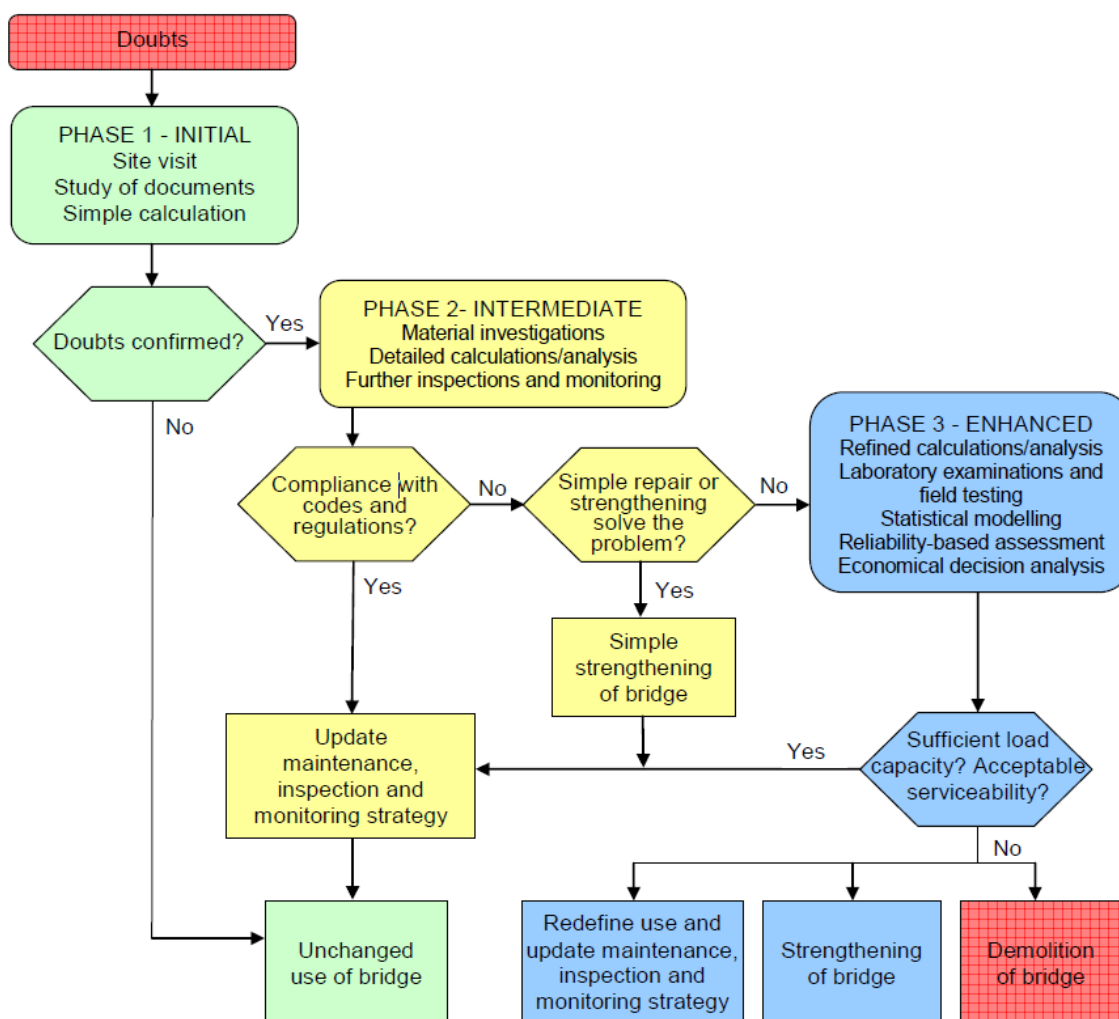

**FIGURE 5.1** FLOW CHART FOR ASSESSMENT OF EXISTING BRIDGES AND OTHER STRUCTURES. THREE PHASES ARE IDENTIFIED: INITIAL, INTERMEDIATE AND ENHANCED DEPENDING ON THE COMPLEXITY OF THE QUESTIONS INVOLVED. SB-LRA (2007). UIC 778-4(2009), ML-D1.4 (2014), PAULSSON ET AL (2016).

There are at least 250,000 railway bridges in Europe and nearly 75 % of these are older than 50 years, with about 35 % being older than 100 years, SB-D1.2 (2004), SB-D1.4 (2005).

Most infrastructure managers have a bridge management system (BMS) with various levels of explicit details. Some examples are: Latvia (Lat Brutus), The Netherlands (DISK), Spain (SGP), Japan (JBMS), Ireland (Eirspan), Germany (GBMS), Finland (FBMS), Denmark (DANBRO), Switzerland (KUBA), and Sweden (BaTMan), see (Mirzaei et al, 2012). The bridges are in most countries well documented and maintained in a professional way. This means that the challenge for bridge managers is how regular operation and maintenance shall be used as input when upgrading in an optimal way, ML-D1.4 (2014), (Casas, 2015).

As an example, Sweden uses an internet based system is used since 2004, BaTMan (2017). In the system, the structure can be found and it can be assessed whether enough data regarding drawings and design calculations is available in the system or if you have to search manually in the archives.

When upgrading a system, five principle methods can be used, see Figure 5.2: (a) Refined calculations; (b) Increased cross section; (c) Change of static system; (d) External prestressing; and (e) Externally bonded reinforcement e.g. Fibre Reinforced Polymers (FRP).

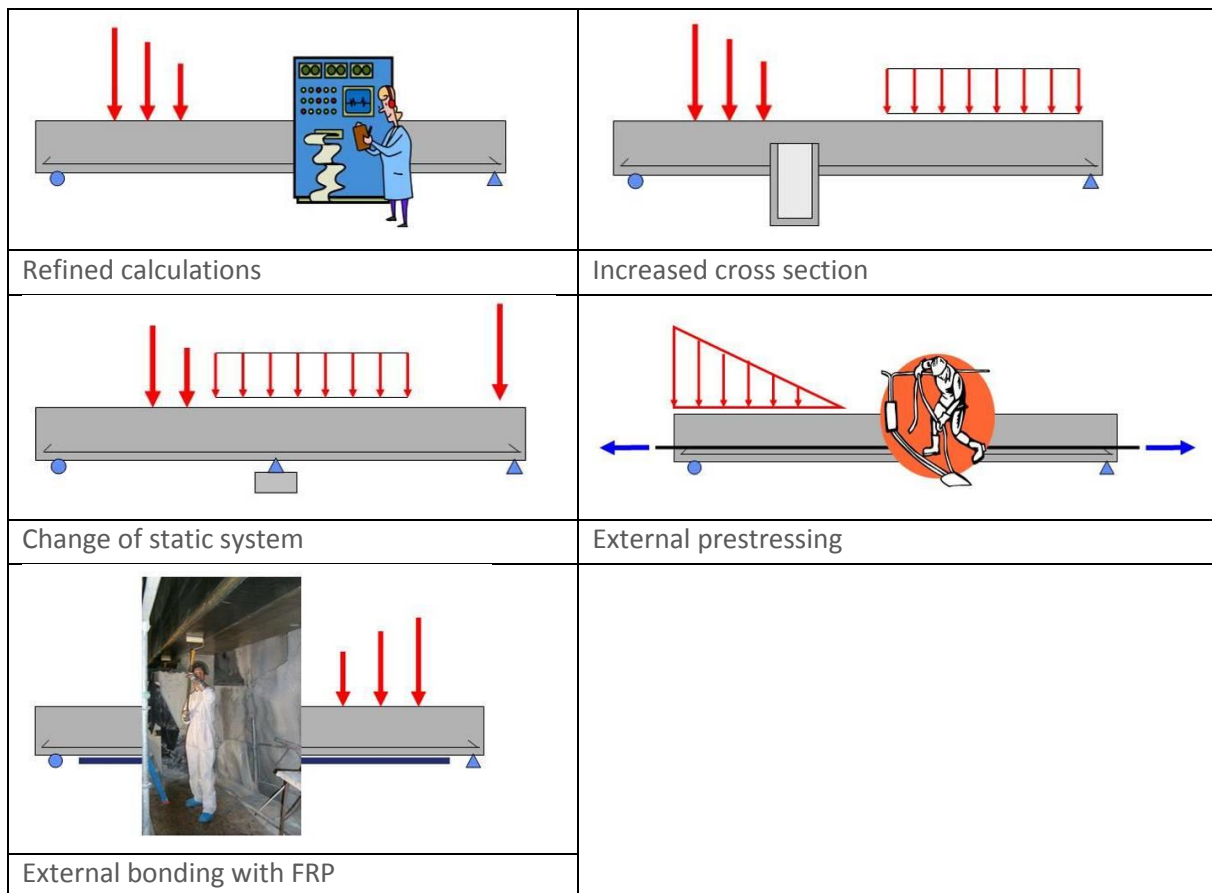

FIGURE 5.2. GENERAL UPGRADING METHODS, SB-STR (2007), ML-D1.4 (2014).

Upgrading and strengthening for the most common types of railway bridges will be treated in the following order: foundations, metallic bridges, masonry bridges, concrete bridges, prestressed bridges and composite bridges. For other types of bridges, such as suspension bridges, a special study has to be made for each individual bridge although the same principles can be applied as presented below.

### 5.3 FOUNDATIONS

An example of how a foundation can be arranged is given in Figure 5.3 The subsoil conditions in the transition zones at the bridge abutments often govern the applicable strengthening methods.

Methods for strengthening and upgrading that can be used are e.g. deep mixing of the soil, jet grouting, sheet pile walls/stabilizing berms, compacting grouting and embankment piling (see Chapter 4).

Examples and case studies are given in SB-STR (2007). The transition zones when the rails pass from the embankment to the bridge may cause “bump” problems due to different stiffness, see SB-LRA (2007) and (Fara, 2014).

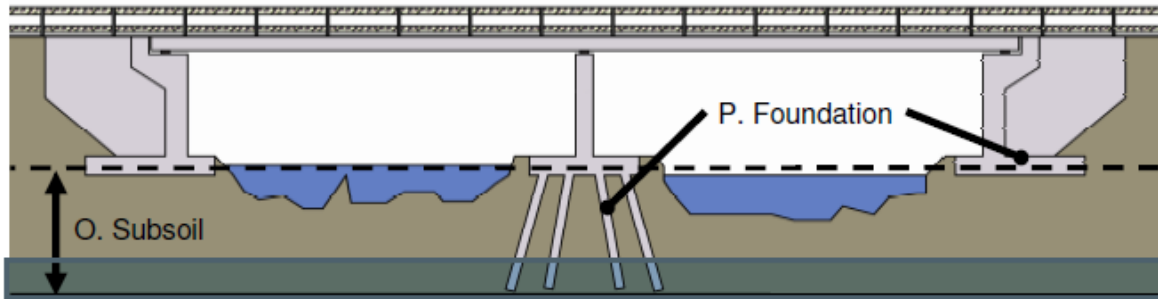

FIGURE 5.3 EXAMPLE OF A FOUNDATION WITH PILES OR SLABS (P) RESTING ON SUBSOIL (O), SB-STR (2007), ML-D1.4 (2014).

Low stability of embankment in transition zones might be a problem, see Figure 5.4. Slip surfaces for stability calculations in Figure 5.4, may need refined methods in deformation-softening clays, see (Bernander et al, 2011 and 2016), (LaBoe, 2015).

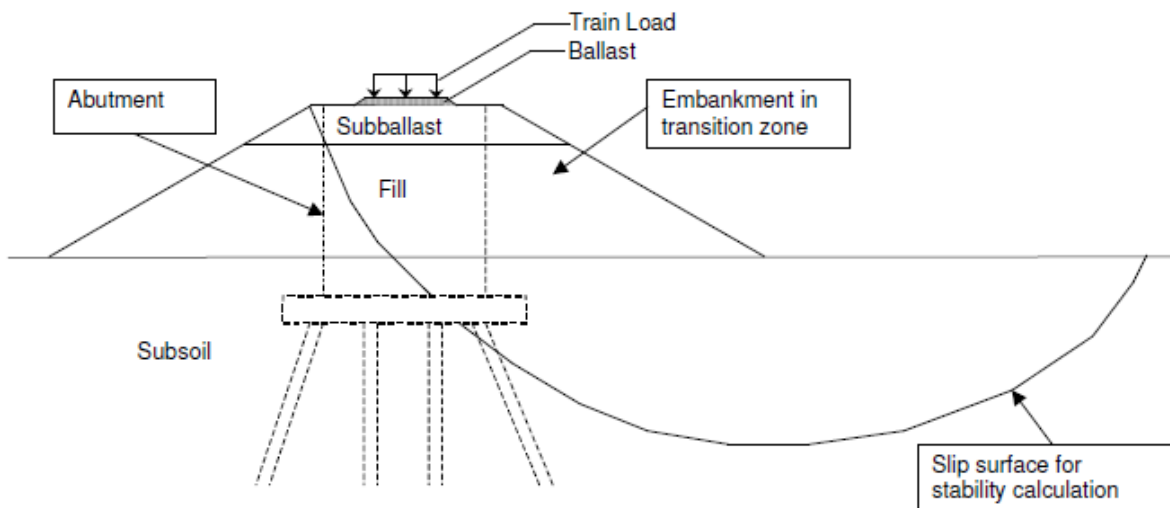

FIGURE 5.4 PRINCIPLE FOR THE ANALYSIS OF STABILITY OF EMBANKMENT IN TRANSITION ZONES, SB-STR (2007), ML-D1.4 (2014). ON LONG SLOPES WITH A MODERATE INCLINATION PROGRESSIVE FAILURE MAY BE INDUCED BY HIGHER LOADS, SEE E.G BERNANDER ET AL. (2011, 2016).

## 5.4 METALLIC BRIDGES

Metallic bridges can be made of cast iron, wrought iron, steel, stainless steel or aluminium. They can have several different designs such as girder, truss and box girder bridges. In addition to this, metallic bridges can be found in almost any design with different material qualities for different structural members within the same structure, SB-LRA (2007).

### 5.4.1 METALLIC TRUSS BRIDGE

The superstructure of a truss bridge commonly consists of two vertical trusses on each side of the track. The track can also be located above the truss beams. The trusses are often the primary structural elements of the bridge and they consist of many members, such as top and bottom elements, diagonal and vertical struts, and end struts. These members form the truss and are mainly subjected to tensile or compressive forces. A horizontal truss at the top or bottom of the bridge gives horizontal stability. The horizontal truss gives bearing capacity for horizontal loads from wind and horizontal accelerations of the train. Bolts or rivets mutually connect all truss members.

A schematic truss bridge is shown in Figure 5.5. This type is often used for bridges that were built before 1950s with medium span lengths.

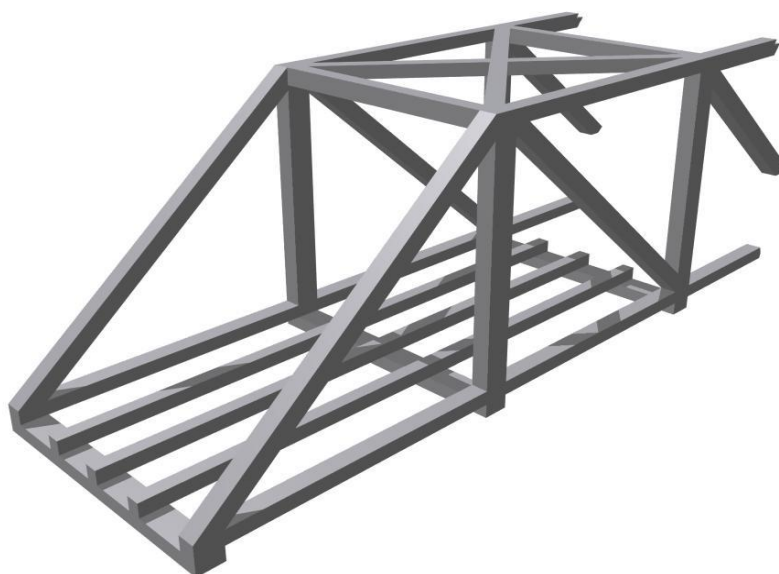

**FIGURE 5.5 METALLIC TRUSS BRIDGE, SB-STR (2007), ML-D1.4 (2014)**

Typical causes for upgrading are:

- Deficient global bearing capacity or stiffness, or deficient tensile capacity in structural elements and joints. This can be remedied with external longitudinal pre-stressing
- Deficient compression bearing capacity of beam-like elements. Relatively many structures are slender and have more than sufficient compression strength, hence global buckling limits the capacity of these structures. This can be remedied with external Carbon Fibre Reinforced Polymer (CFRP) plates or sheets, or by increasing the cross section.
- Deficient bearing capacity of joints including rivets. Cross-sections are often changed in connection to joints, which leads to additional stress concentrations, which in turn may cause fatigue problems. This can be remedied by external pre-stressing and/or replacement of components as rivets and bolts.
- Deficient shear bearing or buckling capacity of webs or flanges. Longitudinal and/or transverse stiffeners and/or external CFRP can remedy this.
- In conjunction to welds, cross-sections are changed, which causes additional stress concentration, which in turn may cause fatigue problems and possible crack initiation and growth. This can be remedied by repair welding of cracks, drilling of stop holes, and external prestressing or external CFRP.

Two examples are given below in section 5.7.1

#### 5.4.2 METALLIC BEAM BRIDGES

Examples of methods are given in SB-D3.4 (2007), SB-ICA (2007) and SB-LRA (2007). Fatigue problems are studied in (Kühn et al, 2008). An example of a main steel girder in a beam bridge is given in Figure 5.6.

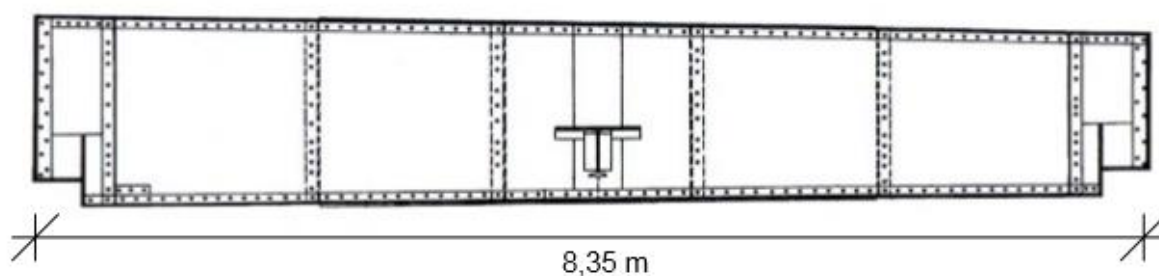

FIGURE 5.6. FRONT VIEW OF THE MAIN STEEL GIRDER FOR AN INVESTIGATED STEEL BEAM BRIDGE, SB-D3.4

#### 5.4.3 OTHER METALLIC BRIDGES

Arch bridges are sometimes made of steel. An example is given in Section 5.7.1.

## 5.5 MASONRY BRIDGES

It is vital from the outset that a holistic approach is taken in the assessment and upgrading/strengthening of masonry arch bridges. To change the nature and/or stiffness of one element of the bridge may result only in re-distribution of stresses, which may cause overstressing of another element. Since most masonry arch bridges will be expected to remain in service for a considerable period in the future, it is important not to carry out works that might compromise their inherent durability, e.g. increase the working stress regime in the masonry and thus potentially reduce its fatigue life.

Masonry bridges can be found in a large variety of designs. The arch may have different numbers of rings and different formations. Masonry arch bridges are usually defined by the material from which they are constructed, the shape of the arch, number of spans and its orientation; for example, a “stone, segmental, 3-span, skewed masonry arch bridge”.

Some areas where upgrading/repairs may be needed are given in Figure 5.7, SB-STR (2007).

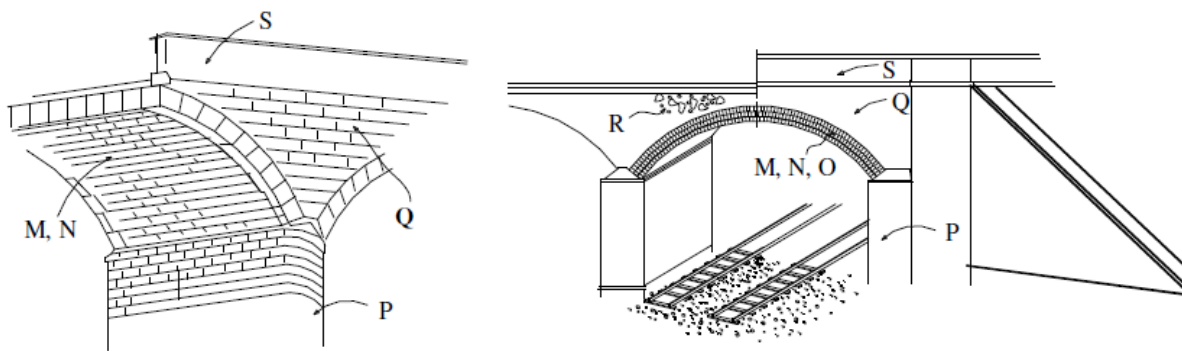

**FIGURE 5.7 MASONRY BRIDGES WITH INDICATIONS OF DIFFERENT AREAS FOR UPGRADING/REPAIR.**

**M – DETERIORATING MASONRY; N – INADEQUATE LOAD CARRYING CAPACITY OF ARCH OR BARREL; O – SEPARATION BETWEEN RINGS IN MULTI-RING ARCH BARRELS (DELAMINATION); P – MOVEMENTS OF PIERS AND ABUTMENTS; Q – SPANDEL WALL MOVEMENT; R – WEAK FILL; S – PARAPET DAMAGE**

Example of upgrading and repair methods for the different areas in Figure 5.7 are:

- M Deteriorating masonry:  
Repointing, arch grouting, patch repairs, waterproofing and drainage
- N Inadequate load carrying capacity of arch or barrel:  
Arch distortion remedial work, backfill replacement/reinforcement, concrete saddle strengthening, prefabricated liners, relieving slabs, retro-reinforcement and sprayed concrete lining
- O Separation between rings in multi-ring arch barrels (Delamination):  
Arch grouting, patch repairs, through ring stitching.



- 
- P Movements of piers and abutments:  
Underpinning, patch repairs.
  - Q Spandrel wall movement:  
Backfill replacement/reinforcement, Spandrel strengthening
  - R Weak fill:  
Backfill replacement/reinforcement, grout fill if suitable.
  - S Parapet damage:  
Patch repairs, parapet upgrading.

Examples and methods are given in e.g. SB-LRA (2007) and SB-STR (2007). More material and backgrounds are given in e.g. (Hendry, 1998), UIC 778-3 (2014), SB-D4.7.1 (2007), SB-D4.7.4 (2007) and (Harvey, 2012).

## 5.6 CONCRETE BRIDGES

Relatively many concrete structures have a non-utilized compression capacity. Here the amount of existing steel reinforcement and thereby the tensile strength limits the load carrying capacity. In cases when compressive strength limits the capacity, it is not suitable to give general suggestions for improvement since an extended load carrying section is usually required and also stability issues where suitable solutions depend on the specifics of the situation need to be considered. In this section, possible strengthening needs (with focus on increasing the tensile strength) will be given for T-beam, trough, box and arch bridges.

### 5.6.1 BRIDGES WITH T-BEAMS

In a beam bridge, the beams constitute the main load carrying structural element. They have to carry the loads from the traffic and the weight of the bridge deck as well as the self-weight and also transfer vertical and horizontal forces down to the substructure of the bridge. The beam bridge type of structure includes in situ casting and prefabricated beams and girders. The concrete beam bridge is usually constructed of two or more beams. The beams may be of T-section, rectangular or of other shapes. In Figure 5.8, a beam bridge is shown with marked areas for possible upgrading. Example of upgrading and repair methods for the different areas in Figure 5.8 are given in Table 5.1.

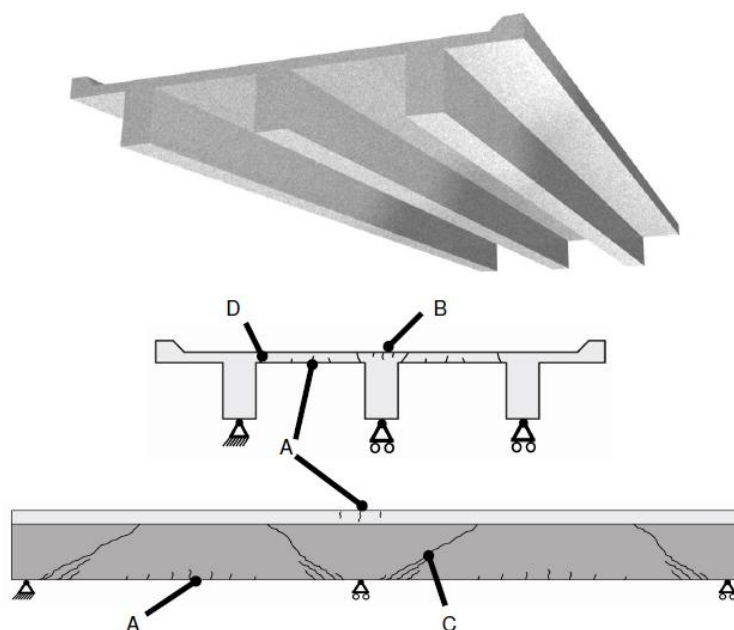
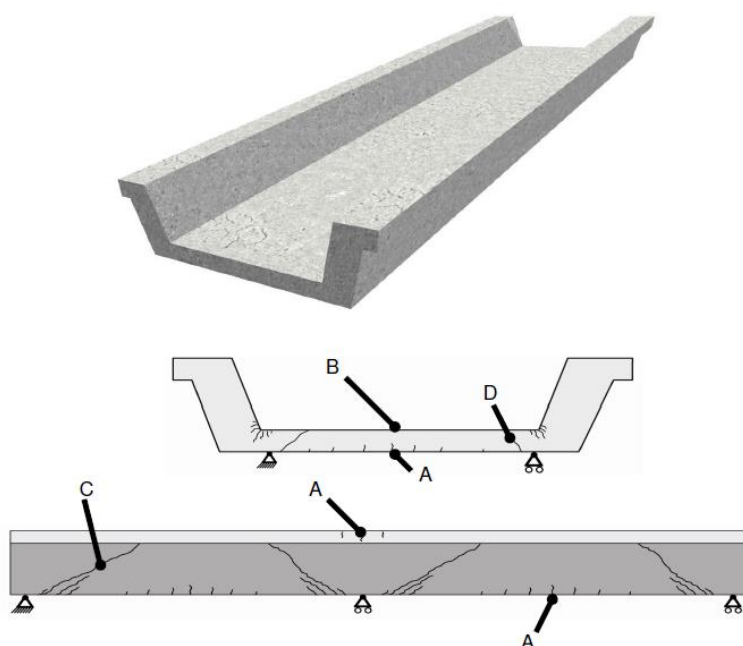

**FIGURE 5.8 BEAM BRIDGE WITH INDICATION OF POSSIBLE AREAS FOR UPGRADING. A – DEFICIENT FLEXURAL BEARING CAPACITY; B - DEFICIENT FLEXURAL BEARING CAPACITY IN AREAS HARD TO ACCESS; C - DEFICIENT SHEAR BEARING CAPACITY IN BEAMS; D - DEFICIENT SHEAR BEARING CAPACITY IN SLABS. SB-STR (2007).**

### 5.6.2 TROUGH BRIDGES

The trough bridge shown in Figure 5.9 can be found in numerous alternative designs. Typically, two main girders, sometimes with a small flange at top, are connected with a slab at the lower part forming a trough. The trough is normally filled with ballast with one or two railway tracks at the same level as the upper part of the girders. The main girders can be different in size and shape with aligned or vertical sides. Trough bridges are often skewed.

Examples of upgrading and repair methods for the different areas in Figure 5.9 are given in Table 5.1.



**FIGURE 5.9 TROUGH BRIDGE WITH INDICATION OF POSSIBLE AREAS FOR UPGRADING. A – DEFICIENT FLEXURAL BEARING CAPACITY; B - DEFICIENT FLEXURAL BEARING CAPACITY IN AREAS HARD ACCESS; C - DEFICIENT SHEAR BEARING CAPACITY IN BEAMS; D - DEFICIENT SHEAR BEARING CAPACITY IN SLABS. SB-STR (2007).**

### 5.6.3 BOX GIRDER BRIDGES

Compared to other beams, the deck of a box girder is identical to the top flange, the walls form the web and the bottom plate is similar to the bottom flange. The box girder bridge, shown in Figure 5.10 is often used for spans in the longer region. In such cases, the bridge carries a high amount of dead weight. Box girder bridges are often post tensioned and often carry two or more railway lines.

Examples of upgrading and repair methods for the different areas in Figure 5.10 are given in Table 5.1.

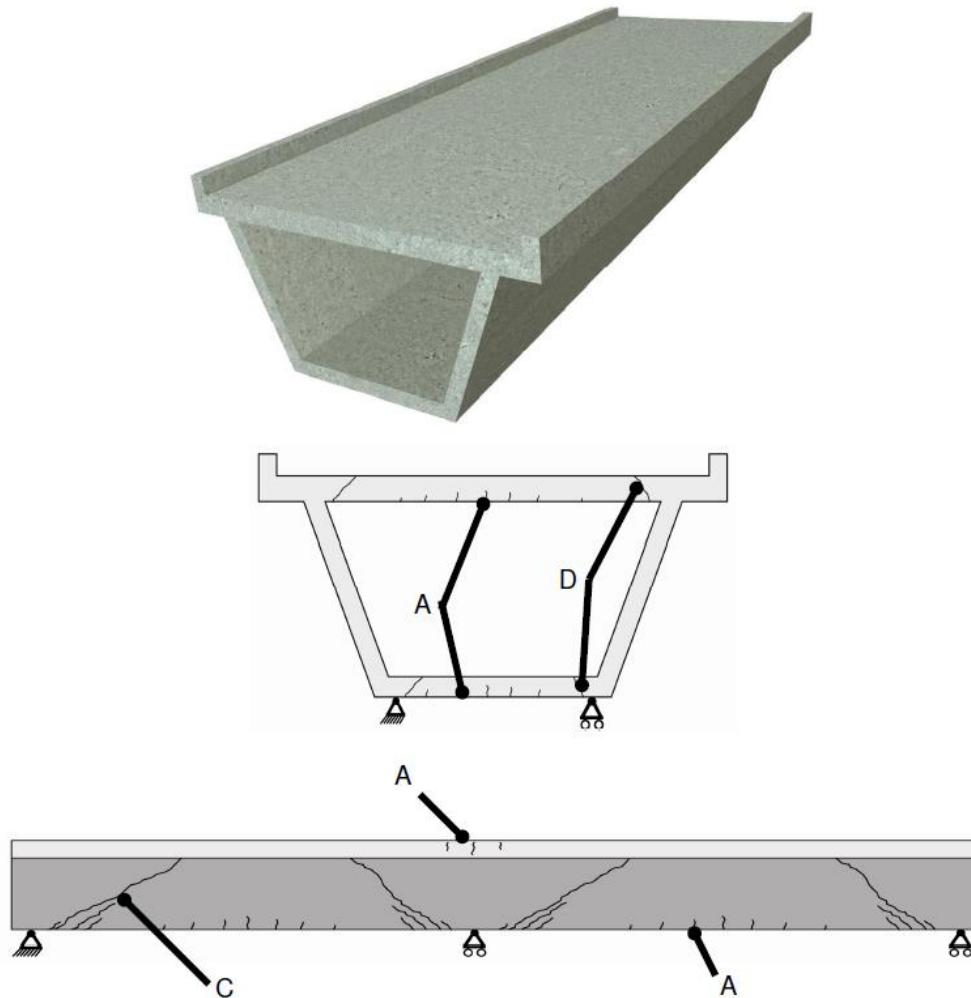

FIGURE 5.10 BOX GIRDER BRIDGE WITH INDICATION OF POSSIBLE AREAS FOR UPGRADING. A – DEFICIENT FLEXURAL BEARING CAPACITY; C - DEFICIENT SHEAR BEARING CAPACITY IN BEAMS; D-DEFICIENT SHEAR CAPACITY IN SLABS. SB-STR (2007).

#### 5.6.4 CONCRETE ARCH BRIDGES

The type of structure termed arch includes open and closed spandrel arch bridges as well as earth filled arch bridges. The bridge deck can be either above, between or underneath the arches. The concrete arch shown in Figure 5.11 can be found in several designs. Most arches are designed to carry loads through compressive forces. However, the arches often contain steel reinforcement and with the required loads of today, bending and tensile strains may be introduced in the arch. This means that arches once designed primarily for compressive forces, may also need to have sufficient shear and bending capacity.

Examples of upgrading and repair methods for the different areas in Figure 5.11 are given in Table 5.1.

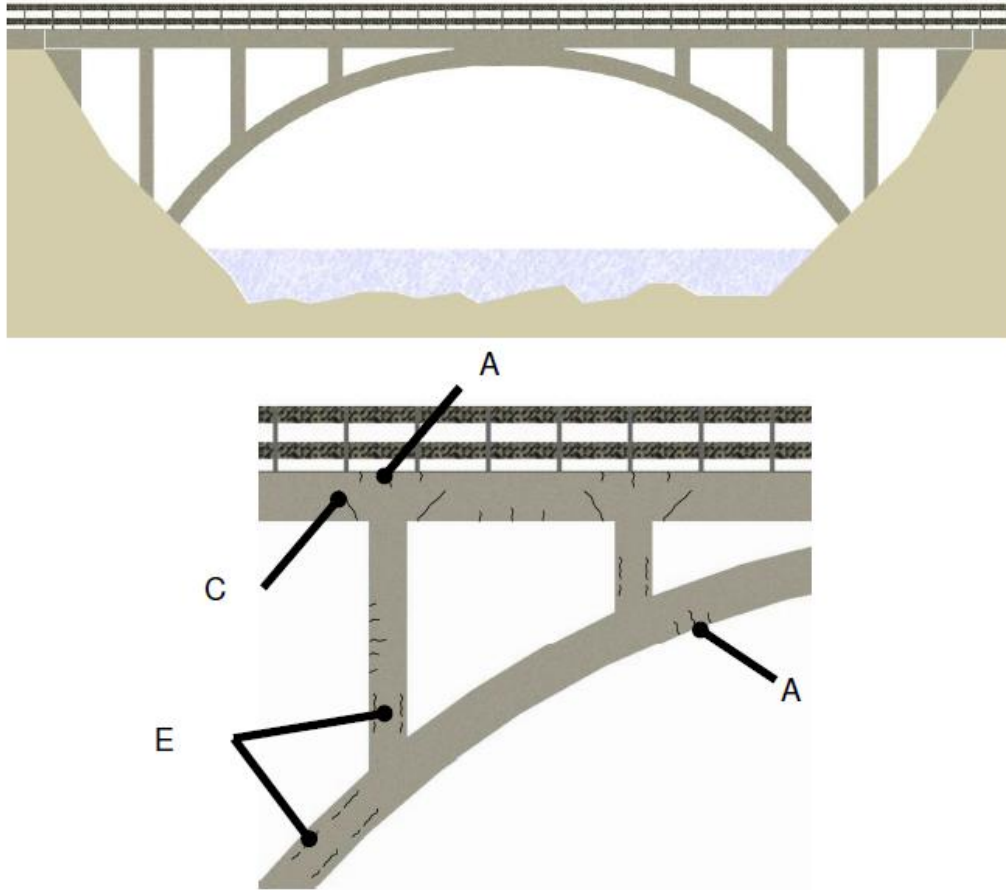

FIGURE 5.11 CONCRETE ARCH BRIDGE WITH INDICATION OF POSSIBLE AREAS FOR UPGRADING. A – DEFICIENT FLEXURAL BEARING CAPACITY; C - DEFICIENT SHEAR BEARING CAPACITY IN BEAMS; E – DEFICIENT BEARING CAPACITY IN COLUMNS AND ARCHES. SB-STR (2007).

### 5.6.5 PRESTRESSED CONCRETE BRIDGES

The difference between reinforced and prestressed bridges is that higher steel qualities are used that makes it possible to pre- or post-stress the concrete in compression so that tensile stresses and cracking can be avoided. Prestressed bridges can therefore often be longer than bridges without prestressing, see e.g. (Collins and Mitchell, 2001). A question that has to be clarified is the condition of the prestressed steel. Sometimes corrosion can be a problem, see e.g. (Haixue, 2014).

The strengthening methods given above for reinforced concrete can often also be used for prestressed concrete. However, in order to get enough effect, the strengthening materials also often need to be pre-stressed. Below in Section 5.7.3 some recent examples are given.

### 5.6.6 COMPOSITE BRIDGES

A structure in which the main bearing elements consist of parts of two different materials in structural cooperation is usually called a composite structure. The most common composite structures in bridges are those based on prefabricated steel girders onto which a slab of concrete is cast. In the same way, it is possible to think of pre-fabricated concrete beams in combination with an on-site cast slab. The slab can in turn be built up of elements of e.g. the so-called “filigree” type with an on-site cast concrete covering, see Figure 5.12.

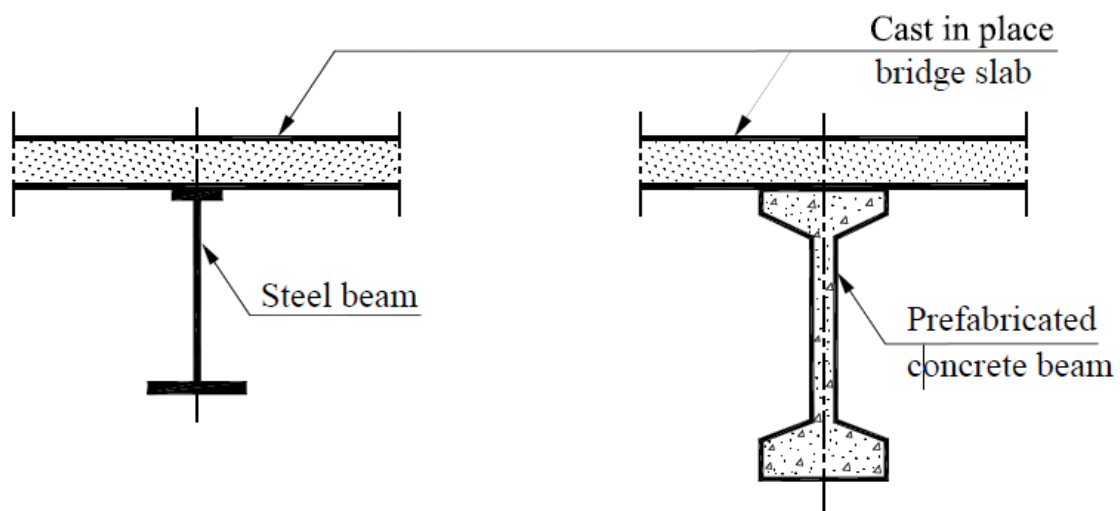

FIGURE 5.12 EXAMPLES OF COMPOSITE STRUCTURES FOR A BRIDGE. COLLIN ET AL (2012).

In order to achieve composite action or cooperation, some component that can transfer shear forces between the structural elements is required. Because of this composite action, a stronger and stiffer structure is obtained with a better utilization of the material. At the same time, it is an advantage that it is possible to prefabricate the main beams.

Bridges based on composite action between steel beams and a concrete slab have been used since the beginning of the 1970s. After the development of effective shear connectors in the form of shear studs this type of bridge has been widely used especially for spans in the order of 30 to 60 meters, see e.g. (Collin et al, 2012), (Collin, 2013), (El Sarraf et al, 2013)

Strengthening of composite bridges can be carried out by the principles presented earlier, i.e. prestressing, or adding steel or CFRP on sections with too high stresses.

### 5.6.7 CONCRETE STRUCTURAL COMPONENTS

There exist other bridges of reinforced concrete which are not presented in this report. However, instead of aiming to present all the possible concrete bridges, structural components used in bridges will be presented below. Figure 5.13 shows a concrete column subjected to high compressive forces.

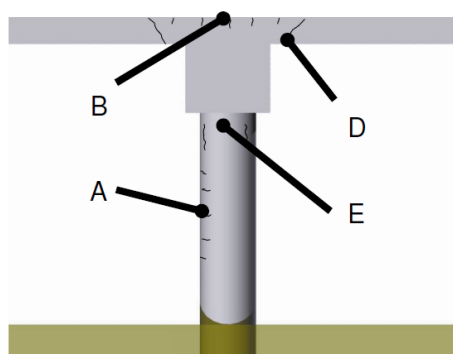

FIGURE 5.13 CONCRETE COLUMN AND SUPPORTING SLAB WITH INDICATION OF POSSIBLE AREAS FOR UPGRADING. A – DEFICIENT FLEXURAL BEARING CAPACITY; B - DEFICIENT FLEXURAL BEARING CAPACITY IN AREAS HARD ACCESS; D - DEFICIENT SHEAR BEARING CAPACITY IN SLABS; E – DEFICIENT BEARING CAPACITY IN COLUMNS AND ARCHES. SB-STR (2007).

Figure 5.14 shows a concrete beam that can be loaded in any direction. However, most common for beam elements is that the element is loaded in a combination of shear and bending.

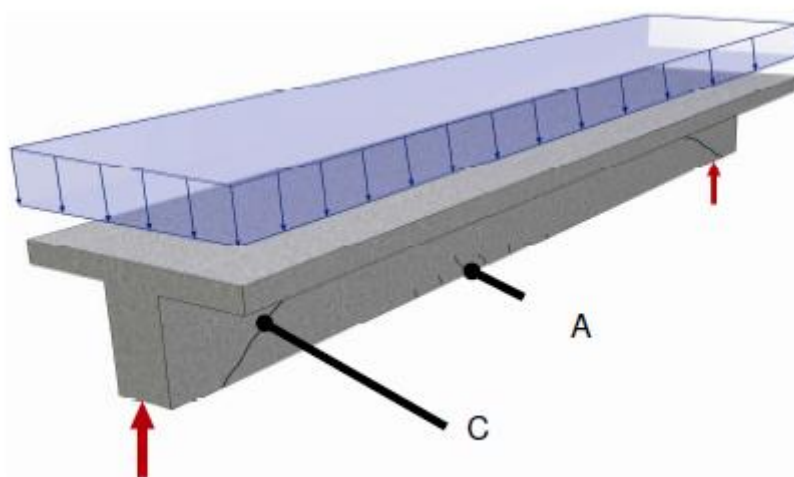

FIGURE 5.14 TYPICAL CONCRETE BEAM WITH INDICATION OF POSSIBLE AREAS FOR UPGRADING. A – DEFICIENT FLEXURAL BEARING CAPACITY; C - DEFICIENT SHEAR BEARING CAPACITY IN BEAMS. SB-STR (2007).

Examples of upgrading and repair methods for the different areas in Figure 5.13 and 5.14 are given in Table 5.1.

## 5.6.8 SUMMARY OF METHODS FOR CONCRETE BRIDGES

TABLE 5.1 EXAMPLES OF UPGRADING METHODS FOR CONCRETE BRIDGES, SB-STR (2007)

	Deficiency	Upgrading method
A	Flexural bearing capacity	External Carbon Fibre Reinforced Polymer (CFRP) Plate or Sheet
		Mineral Based Composite (MBC)
		Near Surface Mounted Reinforcement (NSMR)
		External prestressing
		Increased cross section
B	Flexural bearing capacity hard to access	External prestressing
		Internal rods in drilled holes
C	Shear in beams	External Carbon Fibre Reinforced Polymer (CFRP) Plate or Sheet
		Mineral Based Composite (MBC)
		Near Surface Mounted Reinforcement (NSMR)
		External prestressing, longitudinal or transversal
		New stirrups and concrete casting
		Internal steel/CFRP rods
		Stitching
Fibre reinforced shotcrete		
D	Shear in slabs	Internal steel/CFRP rods
		Internal or external prestressing
		Increase of load-transfer area
E	Columns	External Carbon Fibre Reinforced Polymer (CFRP) Plate or Sheet
		Steel jacket
		Increased reinforced cross section

Examples of methods with prestressing are given in e.g. (Siwowski & Zóltowski, 2012) and (Nilimaa, 2015), see chapter 5.7.3

Methods for design of upgrading are given in e.g. ACI 440.4R-04 (2004), ACI 440.1R-06 (2006), SB-STR (2007), (Reid, 2009), (Täljsten et al, 2011), fib B62 (2012), ML-D1.4 (2014) and (Zilch et al, 2014) An example of the assessment of the effect of various strengthening techniques is given in (Puurula et al, 2015), see section 5.7.2 below.

In (Noël & Souki, 2013) tests on the effect of pre-stressing on the performance of glass fibre reinforced polymers (GFRP)-reinforced concrete slab bridge strips is presented.

## 5.7 EXAMPLES OF ASSESSMENT, STRENGTHENING AND TESTING OF BRIDGES

The hidden capacity of bridges can be found by an enhanced assessment procedure. Several such assessments have been confirmed by load tests to failure of structures that have been – or were



scheduled to be – taken out of service. The testing is also a perfect way to calibrate models for the load-carrying capacity. Important experiences in recent projects have been obtained in this way. Case studies and examples of upgraded structures are given in SB-STR (2007), ML-D1.3 (2015) and ML-D1.4 (2015). A summary and an overview of 28 concrete bridges tested to failure are given in (Bagge et al, 2017c).

Below some examples are given of assessment, strengthening and testing of bridges.

### 5.7.1 STEEL TRUSS BRIDGES

After an enhanced assessment process, a partial replacement of the superstructure of an old truss bridge is often an economic way to upgrade the capacity and to prolong service life of the whole structure. Usually three critical constraints are present: (1) working with short possession times; (2) limited substructure capacity; and (3) limited budget.

An example of such a replacement is the exchange of the steel truss deck of the arch bridge at Forsmo over the Ångerman River in Northern Sweden; see Figure 5.15 to 5.17 (Enevoldsen et al, 2002), (Collin et al, 2010).

Another example is the strengthening by prestressing of an 85 year old four span truss bridge over Skellefteå River in 1996, see SB-STR (2007), Case study CS005:02.

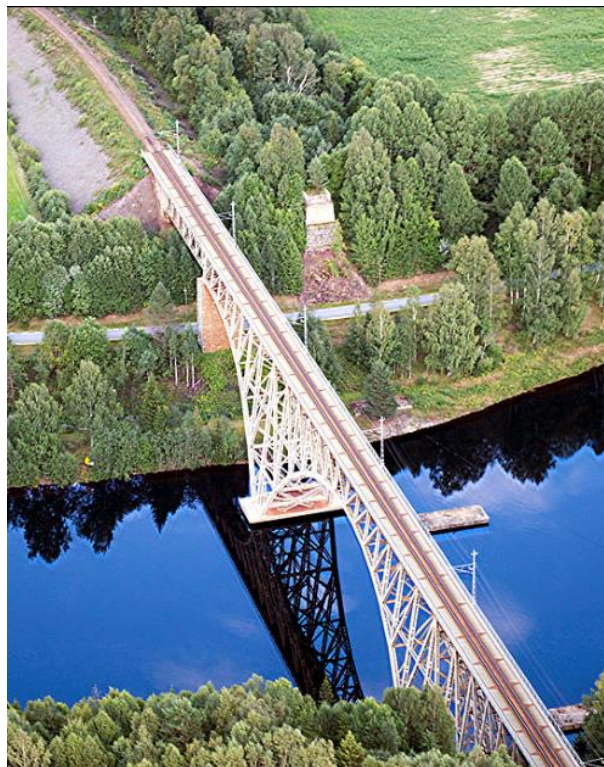

FIGURE 5.15 FORSMO BRIDGE OVER ÅNGERMAN RIVER, SWEDEN, AFTER STRENGTHENING;



FIGURE 5.16 STEEL TRUSS ARCH WITH REPLACEMENT OF TOP STRUCTURE AT THE FORSMO BRIDGE. COLLIN ET AL (2010).

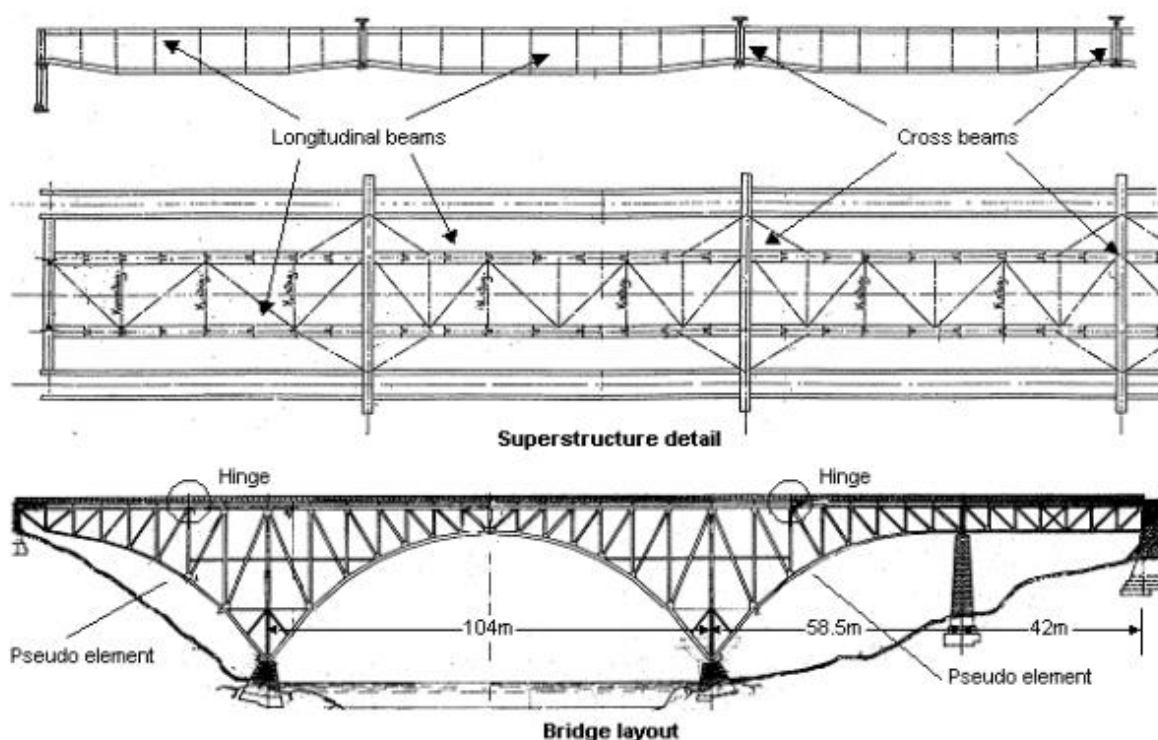

FIGURE 5.17 CHANGE OF SUPERSTRUCTURE OF THE FORSMO BRIDGE

In the MAINLINE project a 55-year-old 33 m long metallic truss bridge, the Åby Bridge, was assessed and tested in 2013. This bridge could also carry loads much higher than the design loads, ML-D1.3 (2015), see Figure 5.18. The regulated axle load on the route (25 tons) was exceeded approximately 4 times before a non-linear behaviour of the deflection the mid span occurred, and almost 6 times before the ultimate load was exceeded. The structural behaviour of the Åby Bridge remained ductile and the maximum load was reached in a nondramatic fashion without failures in joints. No fatigue problems could be found and the final collapse was due to buckling of the top frame beam, ML-D1.3 (2015), (Blanksvärd et al, 2014), (Häggström et al, 2016 and 2017).



**FIGURE 5.18 TEST OF 55 YEAR OLD 33 M LONG METALLIC BRIDGE AT ÅBY RIVER IN 2013. OVERVIEW OF TEST SITE WITH TWO JACKS ANCHORED IN THE BED ROCK IN THE CENTRE (LEFT) AND FINAL BUCKLING FAILURE OF TOP GIRDER BEAM (RIGHT), ML-D1.3 (2015), HÄGGSTRÖM ET AL (2016, 2017).**

### 5.7.2 CONCRETE TROUGH BRIDGES

The possibilities were investigated to increase the axle load on Malmbanan (the Iron Ore Line in northern Sweden) from 25 to 30 ton. A full-scale test was carried out in the laboratory at Luleå University of Technology of a 29-year-old trough bridge with a length of 7,2 m, see Figure 5.19 (Paulsson and Töyrä, 1996), (Paulsson et al, 1996 and 1997), (Thun et al, 2000 and 2006) and (Elfgren, 2015). Before the final test, the bridge had been loaded with 6 million load cycles with an axle load of  $1,2 \times 30 = 36$  ton without any notable damage formation and with only hairline cracks in the bottom of the slab. The tests showed that the fatigue capacity of the bridge was much higher than what was predicted by the codes, (Thun et al, 2000 and 2006).

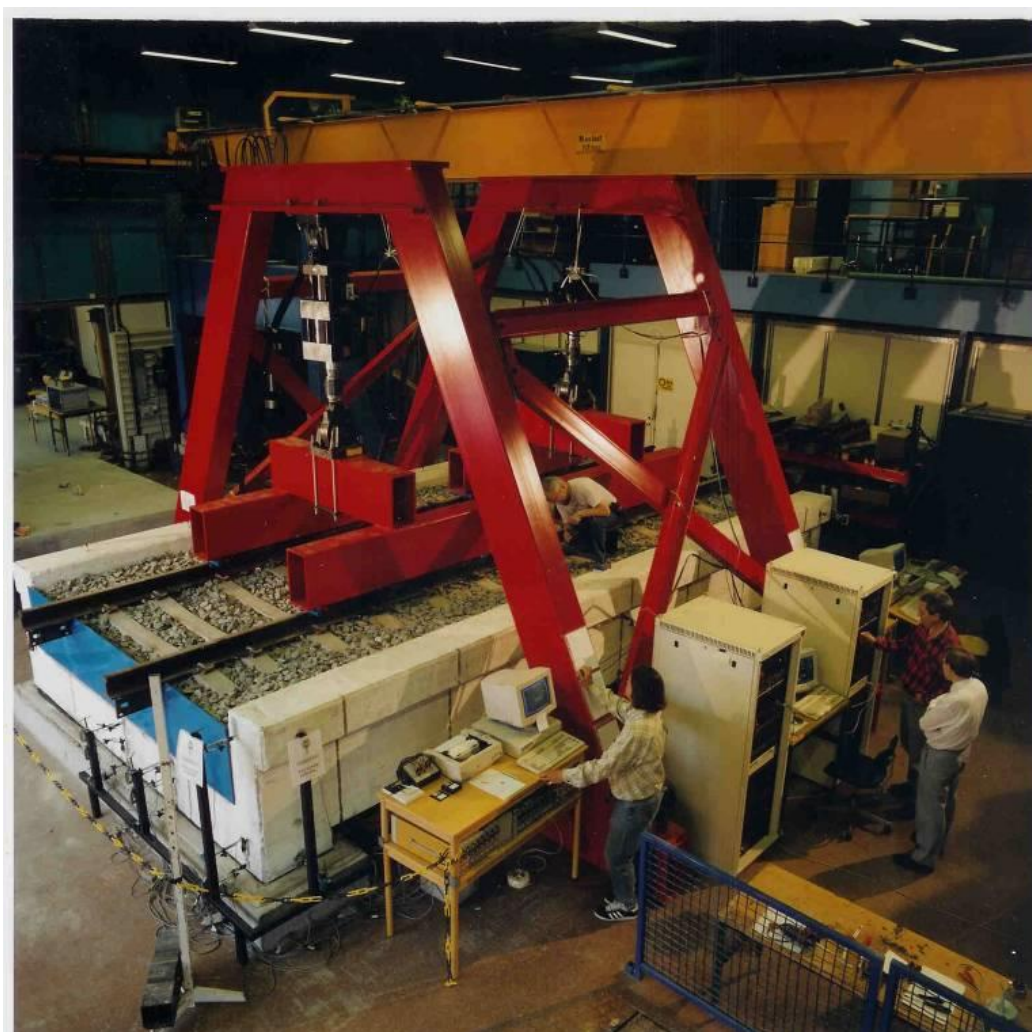

**FIGURE 5.19 FULL SCALE TEST OF A 29-YEAR-OLD RAILWAY TROUGH BRIDGE AT LULEÅ UNIVERSITY OF TECHNOLOGY. PAULSSON ET AL (1996, 1997), THUN ET AL. (2000), ELFGREN (2015).**

Another trough bridge on the Iron Ore Line at Luossajokk was assessed in 2002 with a reliability-based method to see if it could carry an increased axle load of 30 tonnes. It was shown that a satisfactory reliability index of  $\beta > 4.75$  could be reached for reasonable combinations of loads, (Enochsson et al, 2002).

In the Sustainable Bridges Project a 51-year old, two-span trough bridge (12 + 12 m) was assessed and strengthened in bending with Near Surface Mounted Reinforcement (NSFR) consisting of rectangular Carbon Fibre Reinforced Polymer (CFRP) bars glued into grooves sawn into the bottom of the slab. The bridge was then tested to failure in 2006 and an interesting combined failure in bond, shear, bending and torsion was obtained for a load six times the design load, see Figure 5.20, SB-D7.3 (2008), (Puurula et al, 2012, 2014, 2015 and 2016).



**FIGURE 5.20 TEST TO FAILURE OF A STRENGTHENED TROUGH IN ÖRNKÖLDSVIK, 2006. TOP: OVERVIEW OF BRIDGE WITH EAST RAIL BANK CUT AWAY AND REPLACED BY A TEMPORARY ROAD TO SUBSTITUTE THE LANE UNDER THE BRIDGE SPAN BEING TESTED. BELOW: DETAIL OF FAILURE IN SOUTH BEAM CAUSED BY A COMBINATION OF STRESSES DUE TO BOND, SHEAR, BENDING AND TORSION. SB-D7.1 (2006), PUURULA ET AL (2012, 2014, 2015, 2016)).**

In another example of reinforcement, the load carrying capacity of a trough bridge in Haparanda, Sweden, was increased from an axle load of 250 kN to 300 kN by prestressing the slab, see figure 5.7.7, ML-D1.1 (2013), Nilimaa et al (2013, 2014, 2015).



**FIGURE 5.21 UPGRADED CONCRETE TROUGH BRIDGE BUILT IN 1959 IN HAPARANDA IN NORTHERN SWEDEN. IN 2012 THE BRIDGE WAS STRENGTHENED WITH EIGHT POST-STRESSED BARS INSTALLED IN HOLES DRILLED THROUGH THE SLAB (INSERT LEFT). ML-D1.1 (2013), (NILIMAA ET AL, 2013, 2014, 2015).**

An example of an assessment of a concrete arch bridge over the Kalix River at Långforsen in northern Sweden is given in Figure 5.22 (Wang et al, 2016), (Sabourova et al, 2017). The bridge was built in 1960, has a total length of 176,5 m and a mid-span length of 89.5 m and was assessed with finite element simulations calibrated towards measurements of strains deflections and accelerations. The axle load could be increased from 225 to 300 kN.



**FIGURE 5.22 THE BRIDGE OVER KALIX RIVER AT LÅNGFORSEN (WANG ET AL, 2016), (SABOUROVA ET AL, 2017).**

### 5.7.3 PRESTRESSED BRIDGES

In (Hassam and Rizkalla, 2002) half-scale models of a pre-stressed concrete bridge were tested to failure. The test specimens consisted of one simple span and two overhanging cantilevers. Each specimen was tested three times using a different load location in each case. Five different strengthening techniques were investigated including near surface mounted Leadline bars, C-Bars, CFRP strips and externally bonded CFRP sheets and strips. Ultimate capacity, failure mechanism and cost analysis of various strengthening techniques for concrete bridges were presented.

In (Velerino et al, 2006) the shear capacity of a pre-stressed concrete bridge was increased by using embedded Fibre Reinforced Polymer (FRP) bars.

In (Czaderski & Motavalli, 2007) pre-stressed CFRP were applied to strengthen a 17 m long pre-stressed I-beam that had been a part in the “Viadotto delle Cantine a Capolago” bridge constructed 40 years before the test, see Figure 5.23.

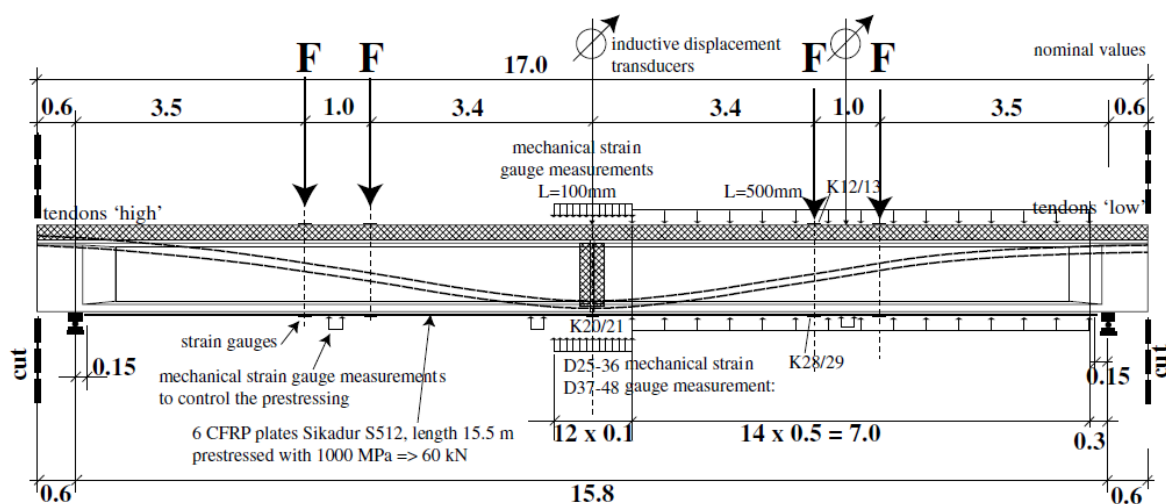

FIGURE 5.23 TEST SETUP OF A PRESTRESSED 40-YEAR-OLD GIRDER STRENGTHENED WITH PRESTRESSED CFRP PLATES, CZADERSKI & MOTAVALLI (2007).

In 2014 a 55-year-old five span prestressed concrete beam bridge with a total length of 121.5 m was assessed and tested to failure in Kiruna in northern Sweden, see Figure 5.24 and 5.25, (Bagge et al, 2014, 2015, 2016 and 2017a, b) and (Nilimaa, 2015).

The project provided a rare opportunity to monitor a post-tensioned concrete bridge during tests to failure using a wide array of instruments. The primary aim was to acquire relevant data for calibration and development of methods for assessing prestressed and posttensioned concrete structures. The test programme included evaluations of the behaviour of the super-structure, two Carbon Fibre Reinforced Polymer (CFRP) strengthening systems, and conditions of the post-tensioned cables.

The Near Surface Mounted (NSM) Carbon Fibre Reinforced Polymer (CFRP) systems used for strengthening did function. However, the prestressed laminates debonded at rather early stages of loading.



**FIGURE 5.24 TEST TO FAILURE OF A STRENGTHENED PRESTRESSED FIVE SPAN BRIDGE IN KIRUNA IN 2014. OVERVIEW FROM N-E WITH THE LKAB IRON ORE MINE IN THE BACKGROUND. (BAGGE ET AL, 2014, 2015, 2016, 2017A,B)**

Comparison of the test result and preliminary analytical calculations indicates difficulties to accurately predict the load-carrying capacity. Undoubtedly, redistribution of internal forces took place in the structure and should be taken into account in assessment. The shear model in the European standard (CEN, 2005) in combination with linear elastic analysis with redistribution was not able to reflect the failure of the bridge. The load-carrying capacity was underestimated and the critical section was inaccurately located. A method to gradually increase the quality of the numerical model was introduced. It corresponds to the enhanced phase in Figure 5.1. The increased quality produced results much closer to the test values, see Figure 5.25. Updated values were used for the boundary conditions of the columns (somewhat built-in rather than hinged) and a lower concrete tensile capacity and fracture energy than what was indicated by the concrete compression strength.

Results on testing and analyzing the remaining prestressing forces are presented in (Bagge et al, 2017a,b). Corrosion of tendons could barely be seen in the bridge. However, in other bridges, tendons have failed due to and deficient grouts with voids, see e.g. (Permeah et al, 2016) and (Haixue, 2014):



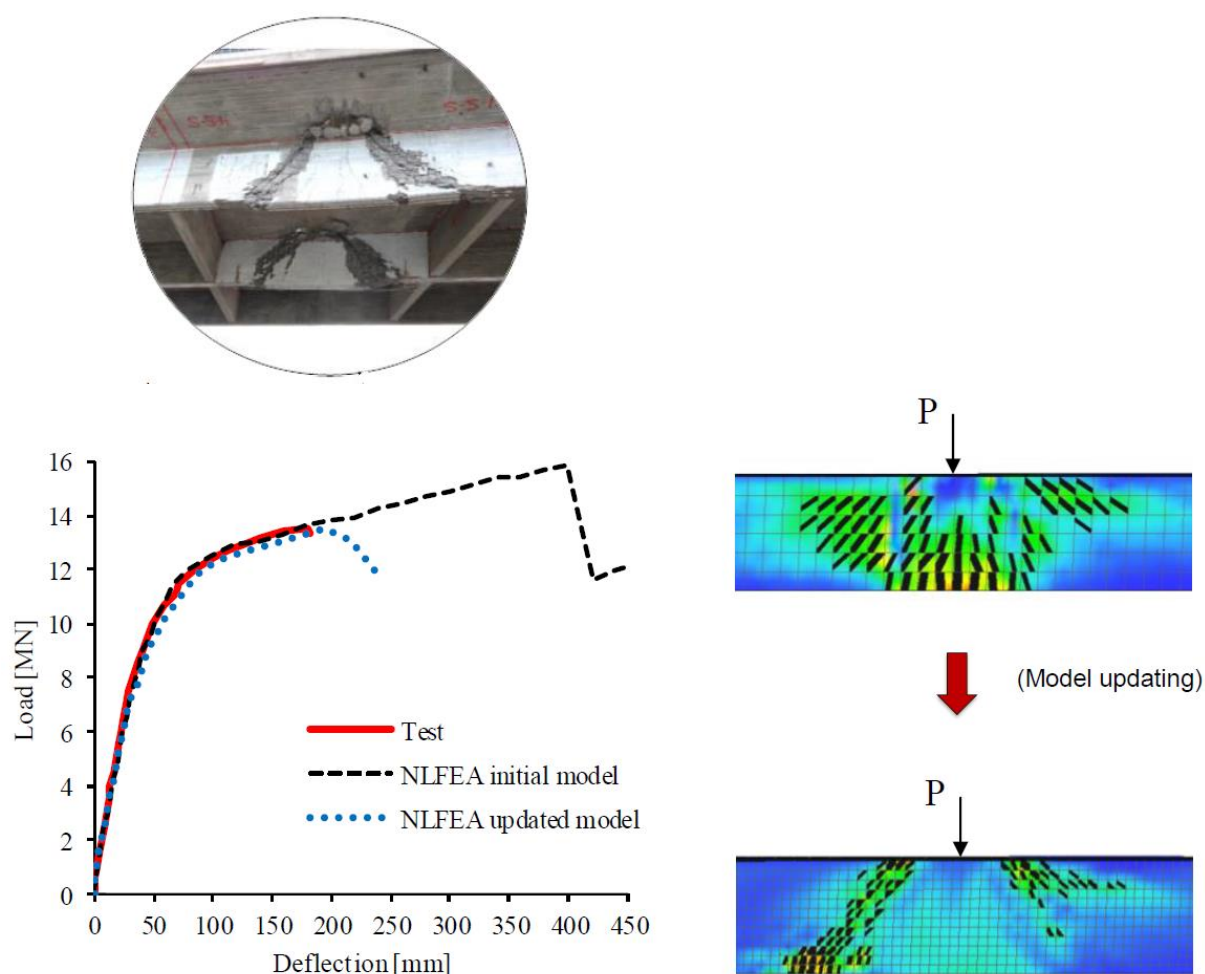

FIGURE 5.25 TESTED AND SIMULATED LOAD-DISPLACEMENTS RELATIONSHIPS USING INITIAL AND UPDATED MODELS FOR THE FAILURE OF THE BRIDGE GIRDERS. PHOTO AND MODELS OF THE SOUTH GIRDER AFTER FAILURE. (BAGGE, 2017A).

## 5.8 REFERENCES

ACI 440.1R-06 (2006): "Guide for the design and construction of structural concrete reinforced with FRP bars." ACI 440.1R-06, American Concrete Institute, Detroit

ACI 440.4R-04 (2004): "Prestressing concrete structures with FRP tendons." ACI 440.4R-04, American Concrete Institute, Detroit.

Bagge, Niklas (2014): Assessment of Concrete Bridges: Models and Tests for Refined Capacity Estimates. Licentiate Thesis, Luleå University of Technology. 132 pp. Available at <http://ltu.diva-portal.org/>

Bagge, Niklas; Nilimaa, Jonny; Sas, Gabriel; Blanksvärd, Thomas; Elfgren, Lennart; Tu, Yongming & Carolin, Anders (2015): Loading to failure of a 55 year old prestressed concrete bridge. *IABSE Workshop Helsinki 2015: Safety, Robustness and Condition Assessments of Structures*. Zurich: International Association for Bridge and Structural Engineering, pp. 130-137. Available at <http://ltu.diva-portal.org/>

Bagge, N., Nilimaa, J., Blanksvärd, T., Täljsten, B., Elfgren, L., Sundquist, H., Carolin, A. (2016): Assessment and failure test of a prestressed concrete bridge. In "*Life-Cycle of Engineering Systems: Emphasis on Sustainable Civil Infrastructure*", Ed. by Bakker, Frangopol & van Breugel, London, Taylor & Francis Group, ISBN 978-1-138-02847-0, paper C134, Abstract p 194, Full paper on USB card pp 1958-1063.

Bagge, Niklas (2017a): Structural Assessment Procedures for Existing Concrete Bridges. Experiences from failure tests of the Kiruna Bridge. *Doctoral Thesis*, Luleå University of Technology, ISBN 978-91-7583-879-3, 310 pp. Available at [ltu.diva-portal.org/](http://ltu.diva-portal.org/)

Bagge, N., Nilimaa, J., Elfgren, L. (2017b): In situ methods to determine residual prestress forces in concrete bridges. *Engineering Structures*, Vol. 135, 41-52p.

Bagge, Niklas; Popescu, Cosmin and Elfgren, Lennart (2017c): Failure tests on concrete bridges: Have we learnt the lessons? *Structure and Infrastructure Engineering (NISE)*, published on line, DOI: 10.1080/15732479.2017.1350985

BaTMan (2017): *BaTMan – Bridge and Tunnel Management*. A data base of Swedish bridges and tunnels (In Swedish). Available at <https://batman.trafikverket.se/externportal>

Bernander, Stig (2011): *Progressive Landslides in Long Natural slopes. Formation, Potential Extension and Configuration of Finished Slides in Strain-Softening Soils*. Doctoral Thesis. Luleå University of Technology, Division of Soil Mechanics and Foundation Engineering in cooperation with the Division of Structural Engineering, 3rd revised version, April 2012, 252 pp, ISBN 978-91-7439-283-8. Available at <http://ltu.diva-portal.org/>

Bernander, S., Kullingsjö, A., Gylland, A. S., Bengtsson, P. E., Knutsson, S., Pusch, R., Olofsson, J., & Elfgren, L. (2016): Downhill progressive landslides in long natural slopes: triggering agents and landslide phases modelled with a finite difference method. *Canadian Geotechnical Journal*, Vol. 53, No. 10, pp. 1565-1582, [dx.doi.org/10.1139/cgj-2015-0651](https://doi.org/10.1139/cgj-2015-0651)

Blanksvärd T, Häggström J, Nilimaa J, Sabourova N, Grip N, Täljsten B, Elfgren L, Carolin A, Paulsson B, Tu Y (2014): Test to failure of a steel truss bridge – Calibration of assessment methods, IABMAS, Proceedings of the Seventh International Conference of Bridge Maintenance, Safety and Management, 7-11 July 2014, Shanghai, China, pp 1076-1081

Brühwiler, Eugen (2014): Bridge “examineering” or how monitoring and UHPFRC improve the performance of structures. . In “Bridge Maintenance, Safety, Management and Life Extension”. Edited by Chen, Frangopol & Ruan. Taylor & Francis Group, London, pp 13-26, ISBN 978-1-138-00103-9.

Brühwiler, Eugen (2015): Swiss standards for existing structures – Four years of implementation. IABSE Workshop Helsinki, Safety, Robustness and Condition Assessment of Structures February 11-12, 2015, International Association for Bridge and Structural Engineering, IABSE, Zürich, pp 2 – 11.

BV Bärighet (1996): *Bärighetsbestämning av järnvägsbroar*. (Assessment of Railway Bridges. In Swedish). Handbook BVH 583.11. Edited preliminary version 1996-01-17. Banverket, TB, Sektion Bansystem, Borlänge, Sweden 68 p. Updated several times, see TRVK (2014) and TRVR (2014).

Casas JR (2015): The bridges of the future or the future of bridges? *Frontiers in the Built Environment*. 1:3, 8 April 2015. doi: 10.3389/fbuil.2015.00003

Collin, Peter; Nilsson, Mattias and Veljkovic, Milan (2010); *International Workshop. Strengthening of Steel Bridges*. Stockholm, March 10, 2010. Technical Report, Luleå University of Technology, 324 pp, ISBN 978-91-7439-207-4. The decking change of the Forsmo bridge is presented on pp 169-173. Available at <http://ltu.diva-portal.org/>

Collin, Peter; Johansson, Bernt and Sundquist, Håkan (2012): *Steel Concrete Composite Bridges*. Published jointly as TRITA-BKN, Report 121, Structural Design and Bridges, Royal Institute of Technology, Stockholm and Report LTU:SNB:Byggkon:2008:119:01, Structural Engineering, Luleå University of Technology, 5<sup>th</sup> Ed 2012, 129 pp.

Collins, M.P., Mitchell, D. (2001): *Prestressed Concrete Structures*, Toronto: Response Publications, ISBN 0-9681958-0-6, 766 pp.

Cremona, Cristian (2014): Assessment of existing structures in France: Standard and advanced practices. In “Bridge Maintenance, Safety, Management and Life Extension”. Edited by Chen, Frangopol & Ruan. Taylor & Francis Group, London, pp 27-39, ISBN 978-1-138-00103-9.

Czaderski, Christoph & Motavalli, Masoud (2007): 40-year old full-scale bridge girder strengthened with prestressed CFRP plates anchored using gradient method. *Composites: Part B*, Vol 38(2007) pp 878-886.

Du, Guangli (2015): *Life cycle assessment of bridges, model development and case studies*. Doctoral Thesis, Royal Institute of Technology, Stockholm, TRITA-BLN, Bulletin 129, 171 pp.

EC0 (2002): *Eurocode 0: Basis of structural design, EN 1990;2002*. The Eurocodes are issued by the European Committee for Standardization or, in French: Comité Européen de Normalisation, CEN, and the corresponding national Standard Associations as e.g. the Swedish Standards Institute, SIS. There is

a lot of material developed to assist in the use of the Eurocodes see e.g. handbooks by the Leonardo da Vinci Pilot Project CZ/02/B/F/PP-134007, see below EC Handbook 1-4 (2004-2205)

There was also a dissemination workshop in Brussels in 2008 with many good presentations: <http://eurocodes.jrc.ec.europa.eu/showpage.php?id=332#EN1994> (Assessed 2013-08-06).

EC1 (2002-2006) *Eurocode 1: Actions on structures, EN 1991*. Part 1 (2002-2006): 1-1 Self weight, 1-2 Fire Actions, 1-3 Snow, 1-4 Wind, 1-5 Thermal Actions, 1-6 Construction loads, 1-7 Accidental Actions. Part 2 (2006): Traffic on bridges, Part 3 (2006): Loads from cranes, Part 4 (2006): Silo loads.

EC2 (2004-2006): *Eurocode 2: Design of concrete structures, EN 1992*. Part 1: General rules; Part 2(2005): Concrete Bridges; Part 3(2006): Liquid containment structures.

EC3 (2005-2007): *Eurocode 3: Design of steel structures, EN 1993*. Part 1(2005-2007) Design of steel structures, 12 subparts; Part 2 (2006) Steel bridges; Part 3 (2006): Towers, masts; Part 4 (2007): Silos; Part 5 (2007): Piling; Part 6 (2007): Supporting structures.

EC4 (2004-2005): *Eurocode 4: Design of composite structures, EN 1994*. Part 1 (2004-2005): General rules; Part 2 (2005): Bridges.

EC5 (2004) *Eurocode 5: Design of timber structures, EN 1995*.

EC6 (2005-2006): *Eurocode 6: Design of masonry structures, EN 1996*.

EC7 (2004, 2007): *Eurocode 7: Geotechnical design, EN 1997*.

EC8 (2004-2005): *Eurocode 8: Design for earthquake resistance, EN 1998*.

EC9 (2007): *Eurocode 9: Design of aluminum structures, EN 1999*.

EC Handbook 1 (2004): *Basis of Structural Design. Handbook 1*. Leonardo da Vinci Project CZ/02/B/F/PP-134007. Development of Skills facilitating implementations of Eurocodes, 155 pp. Available at <http://eurocodes.jrc.ec.europa.eu/showpublication.php?id=62>.

EC Handbook 2 (2005): *Reliability Backgrounds. Handbook 2*. Leonardo da Vinci Project CZ/02/B/F/PP-134007. Development of Skills facilitating implementations of Eurocodes, 254 pp. Available at <http://eurocodes.jrc.ec.europa.eu/showpublication.php?id=63>

EC Handbook 3 (2005): *Action effects for buildings. Handbook 3*. Leonardo da Vinci Project CZ/02/B/F/PP-134007. Development of Skills facilitating implementations of Eurocodes, 158 pp. Available at: <http://eurocodes.jrc.ec.europa.eu/showpublication.php?id=64>

EC Handbook 4 (2005): *Design of Bridges. Handbook 4*. Leonardo da Vinci Project CZ/02/B/F/PP-134007. Development of Skills facilitating implementations of Eurocodes, 174 pp. Available at: <http://eurocodes.jrc.ec.europa.eu/showpublication.php?id=65>

Elfgren, Lennart (2015): *Fatigue Capacity of Concrete Structures: Assessment of Railway Bridges*. Report, Luleå University of Technology, 103 pp. ISBN: 978-91-7583-822-9. Available at: <http://ltu.diva-portal.org/>

El Sarraf, Raed; Ilse, David; Momtahan, Amin; Easey, David; and Hicks, Stephen (2013): Steel-concrete composite bridge design guide. September 2013. NZ Transport Agency research report 524, Wellington, 252 pp. Available at <http://www.nzta.govt.nz/resources/research/reports/525/docs/525.pdf>

Enevoldsen, Ib; Pedersen, Claus; Axhag, Frank; Johansson, Örjan and Töyrä, Björn (2002): Assessment and Measurement of the Forsmo Bridge, Sweden. *Structural Engineering International*, Vol 12, No 4, November 2002, pp 254-257.

Enochsson, Ola; Hejl, Arvid; Nilsson, Martin C.; Thun, Håkan; Olofsson, Thomas; and Elfgren, Lennart (2002): *Bro över Luossajokk. Beräkning med säkerhetsindexmetod. Böjdragkapacitet i överkant av mittsnittet i korta spannet*. (Bridge over Luossajokk. Probabilistic assessment of the mid-span bending capacity in the short span. In Swedish). *Technical Report 2002:06*, Luleå: Division of Structural Engineering, Luleå University of Technology. Available at <http://ltu.diva-portal.org/>

Fara, Andrea (2014): Transition Zones for Railway Bridges: A Study of the Sikån Bridge. MSc Thesis, Luleå University of Technology, 205 pp. Available at <http://ltu.diva-portal.org/>

fib B62 (2012): *Structural Concrete. Textbook on behaviour, design and performance. 2nd Ed., Volume 5. Through-life care and management of concrete structures – assessment, protection, repair and strengthening*. International Federation for Structural Concrete (fib), Lausanne, January 2012, 462 pp, ISBN 978-2-88394-102-1.

Haixue, Liao (2014): Post-Tensioned Tendon Corrosion Evaluation and Mitigation. IABMAS Conference, Shanghai, 2015.

Häggström, Jens (2016): Evaluation of the Load Carrying Capacity of a Steel Truss Railway Bridge: Testing, Theory and Evaluation. Licentiate Thesis, Luleå University of Technology, 2016, 142 pp. ISBN: 978-91-7583-740-6, see <http://ltu.diva-portal.org/>

Häggström, J., Blanksvärd, T., Täljsten, B. (2017): Bridge over Åby River: Evaluation of full scale testing. Report, Luleå University of Technology, 2017, 131 pp., see <http://ltu.diva-portal.org/>

Harvey, Bill (2012): *Stiffness and damage in masonry bridges*. Proceedings of the ICE, Bridge Engineering, Vol. 165, Issue 3, pp. 127-134. DOI: [10.1680/bren.11.00032](https://doi.org/10.1680/bren.11.00032). Bill Harvey also has blog on Masonry Bridges: [http://billharvey.typepad.com/archie\\_m/](http://billharvey.typepad.com/archie_m/) (assessed 2017-02-28)

Hassan, Tarek and Rizkalla, Sami (2002): Flexural Strengthening of Prestressed Bridge Slabs with FRP Systems. *PCI Journal*, No 1, Jan-Feb 2002, pp 75-93.

Hendry, A. W. (1998): *Structural Masonry*. London, Macmillan Press Ltd.

ISO 13822 (2010): Basis for design of structures – Assessment of existing structures, Genève ISO, 46 pp.

Johnson, R. P. (2009): *Eurocodes, 1970-2010: why 40 years?*, Proc. of the Inst. of Civil Engineers, Structures and Buildings, Vol. 162, Dec. 2009, Issue SB6, pp. 371-379. doi: 10.1680/stbu.2009.162.6.371

JRC Assessment (2015): *New European Technical Rules for the Assessment and Retrofitting of Existing Structures. Policy Framework. Existing Regulations and Standards. Prospect for CEN Guidance*. Support to the implementation, harmonization and further development of the Eurocodes. JRC Science and Policy Report. Authors Paul Lüchinger et al. Editors Silvia Dimona et al. Report EUR 27128 EN, European Commission, Joint Research Centre (JRC), Institute for the Protection and Security of the Citizen. Ispra 2015, 137 pp., ISBN 978-92-79-46023-4. doi: 10.2788/052881. Available at <http://publications.jrc.ec.europa.eu/repository/handle/JRC94918> or <http://bookshop.europa.eu/en/new-european-technical-rules-for-the-assessment-and-retrofitting-of-existing-structures-pbLBNA27128/>

JRC Bridge Examples (2012): *Bridge Design to Eurocodes. Worked Examples*. Worked examples presented at the Workshop “Bridge Design to Eurocodes”, Vienna, 4-6 October 2010. Support to the implementation, harmonization and further development of the Eurocodes. JRC Scientific and Policy Report. Authors Yosra Bouassida et al., Editors A. Athanasopoulou et al. Report EUR 25193 EN, European Commission, Joint Research Centre (JRC), Ispra 2012, 438 pp., ISBN 978-92-79-22823-0. doi: 10.2788/82360. Available at [http://eurocodes.jrc.ec.europa.eu/doc/1110\\_WS\\_EC2/report/Bridge\\_Design-Eurocodes-Worked\\_examples.pdf](http://eurocodes.jrc.ec.europa.eu/doc/1110_WS_EC2/report/Bridge_Design-Eurocodes-Worked_examples.pdf)

Karbhari, Vistasp M (1998): *Use of Composite Materials in Civil Infrastructure in Japan*. International Technology Research Institute, World Technology (WTEC) Division, US National Science foundation (NSF), 211 pp. ISBN 1-883712-50-5. Available at <http://www.wtec.org/loyola/compce/toc.htm> (Accessed 2015-06-20)

Kühn, B., Lukic, M., Nussbaumer, A., Günther, H.-P., Helmerich, R., Herion, S., Kolstein, M.H., Walbridge, S., Androic, B., Bucak, Ö. (2008): *Assessment of Existing Steel Structures: Recommendations*

for Estimation of Remaining Fatigue Life. Prepared under the JRC-ECCS cooperation agreement for the evolution of Eurocode 3. JRC 43401, ISSN 1018-5593, 90 pp.

LaBoe, Barbara (2015): What we are doing to prevent landslides near rail lines, Washington State Department of Transportation, January 2015. <http://wsdotblog.blogspot.se/2015/01/what-were-doing-to-prevent-landslides.html>

MAINLINE (2014): *A European Community 7<sup>th</sup> Framework Program research project with the full title: MAINTenance, renewal and Improvement of rail transport infrastructure to reduce Economic and environmental impacts*. Research Project 2011-2014 with 19 partners. Grant agreement 285121, SST.2011.5.2-6. Dr. Björn Paulsson, UIC/Trafikverket acted as Project Coordinator. A project summary and 27 deliverables and can be downloaded from [www.mainline-project.eu](http://www.mainline-project.eu)

Michels, Julien; Stáskiewicz, Michel; Czaderski, Christoph; Lasek, Krzysztof; Kotynia, Renata and Motavalli, Masoud (2014): Anchorage resistance of CFRP strips externally bonded to various cementitious substrates. *Composites: Part B*, Vol 63(2014), pp 50-60.

Mirzaei, Z., Adey B.T., Klatter, L., Kong, J. (2012), The IABMAS Bridge Management Committee Overview of Existing Bridge Management Systems, 152 pages. Cited from Du, Guangli (2015): Life cycle assessment of bridges, model development and case studies. PhD Thesis, Royal Institute of Technology, Stockholm, 48 pp + appended papers.

Motavalli, Masoud; Czaderski, Christoph and Pflang-Lang, Kerstin (2011): Prestressed CFRP for Strengthening of Reinforced Concrete Structures: Recent Developments at EMPA, Switzerland. *Journal of Composites for Construction, ASCE*, Vol 15, No 2, April 2011, pp 194-205.

ML-D1.1 (2013): *Benchmark of new technologies to extend the life of elderly rail infrastructure* MAINLINE Deliverable D1.1, 77 pp., see <http://www.mainline-project.eu/>

ML-D1.2 (2013): *Assessment methods for elderly rail infrastructure*. MAINLINE Deliverable D1.2.132 pp, see <http://www.mainline-project.eu/>

ML-D1.3 (2014): *New technologies to extend the life of elderly infrastructure*. MAINLINE Deliverable D1.3. 2014-09-30, revised March 2015, 194 pp, see <http://www.mainline-project.eu/>

ML-D1.4 (2015): *Guideline for application of new technologies to extend life of elderly rail infrastructure*. MAINLINE Deliverable D1.4, 2014-09-30, revised March 2015, 146 pp, see <http://www.mainline-project.eu/>

ML-D5.7 (2014): *Manual for a Life Cycle Assessment Tool (LCAT) for Railway Infrastructure - Metallic Bridges, Track and Soil Cuttings*. Demonstration of MAINLINE LCAT tools for metallic bridges, plain track and soil cuttings with guidance on how to use them. Mainline Deliverable D5.7. <http://www.mainline-project.eu/>

Nilimaa, Jonny (2013): Upgrading concrete bridges. Post-tensioning for higher loads. Licentiate thesis, Luleå University of Technology t, Luleå, 302 pp. Available at <http://ltu.diva-portal.org/>

Nilimaa, Jonny, Blanksvärd, Thomas, Täljsten, Björn & Elfgrén, Lennart (2014): 'Unbonded Transverse Posttensioning of a Railway Bridge in Haparanda, Sweden' *Journal of Bridge Engineering*, ASCE, Vol 19, No 3, 4013001., 10.1061/(ASCE)BE.1943-5592.0000527

Nilimaa, Jonny (2015): Concrete Bridges: Improved Load Capacity. Doctoral Thesis, Luleå University of Technology, 2015, 176 pp. Available at <http://ltu.diva-portal.org/>

Noël, Martin and Souki, Khaled (2013): Effect of Prestressing on the Performance of GFRP-Reinforced Concrete Bridge Strips. *Journal of Composites for Construction*, Vol. 17, No. 2, April 1, 2013, pp 188-196.

Paulsson, Björn and Töyrä, Björn, project leaders (1996): *30 ton på Malmbanan*. (30 ton on the Iron Ore Line. An investigation on raising the axle load from 25 to 30 ton. In Swedish). In the project several studies were carried out regarding different parts of the infra-structure. The studies are presented in a summary report and in seven detailed reports. Jernbaneverket in Norway carried out a similar study for the line Riksgränsen – Narvik. .

- 3.0 Infrastruktur - Broar och Geoteknik (Bridges and Geotechnology. Summary Report), 34 pp
- 3.1 Infrastruktur - Inventering broar (Inventory of Bridges), 22 pp + 8 appendices
- 3.2 Infrastruktur - Beräkningar och konsekvenser – broar (Bridges – Calculations), 48 pp + 10 appendices
- 3.3 Infrastruktur - Forsknings- och utvecklingsprojekt avseende betongbroars bärrighet (Research Project on Bridges), 51 pp + 5 appendices
- 3.4 Infrastruktur - Geoteknisk inventering (Geotechnical Inventory), 53 pp + 14 appendices
- 3.5 Infrastruktur – Stabilitetsutredning (Stability of Embankments), 19 pp + 5 appendices
- 3.6 Infrastruktur - FoU Beräkningsmodell för grundläggning på torv (Foundations on Peat), 53 pp + 11 appendices
- 3.7 Infrastruktur - Geotekniska åtgärder (Geotechnical Actions) 50 pp + 5 appendices

Paulsson, Björn; Töyrä, Björn; Elfgrén, Lennart; Ohlsson, Ulf; Danielsson, Georg; Johansson, Håkan and Åström, Lars (1996): *30 ton på Malmbanan. Rapport 3.3 Infrastruktur. Forsknings- och utvecklingsprojekt avseende betongbroars bärrighet*. (Static tests on four trough bridges and a



laboratory fatigue test on one bridge. In Swedish) Banverket och Luleå tekniska universitet, 51pp + 5 bilagor. Available at <http://ltu.diva-portal.org/>

Paulsson, Björn; Töyrä, Björn; Elfgren, Lennart; Ohlsson, Ulf and Danielsson, Georg (1997): *Increased Loads on Railway Bridges of Concrete*. Advanced Design of Concrete Structures (Ed. By K Gylltoft et al), Cimne, Barcelona, 1997. pp 201-206 (ISBN 84-87867-94-4).

Paulsson, B., Bell, B., Schewe, B., Jensen, J. S., Carolin, A., and Elfgren, L. (2016). Results and Experiences from European Research Projects on Railway Bridges. *19th IABSE Congress Stockholm 21-23 September 2016*, Zürich, 2016, pp. 2570 – 2578. ISBN 978-3-85748-144-4. Available at <http://ltu.diva-portal.org/>

Permech, Samanbar; Vineshwaran, Krishna; Lau, Kingsley (2016): *Corrosion of Post-Tensioned Tendons with Deficient Grout*, Florida Department of Transportation, 202 pp, Available at [http://www.fdot.gov/research/Completed\\_Proj/Summary\\_SMO/FDOT-BDV29-977-04-rpt.pdf](http://www.fdot.gov/research/Completed_Proj/Summary_SMO/FDOT-BDV29-977-04-rpt.pdf)

Puurula, Arto (2012): *Load-carrying Capacity of a Strengthened Reinforced Concrete Bridge: Non-linear Finite Element Modeling of a Test to Failure. Assessment of Train Load Capacity of a Two Span Railway Trough Bridge in Örnsköldsvik Strengthened with Bars of Carbon Fibre Reinforced Polymers (CFRP)(2012)*. Doctoral Thesis, Luleå: Luleå University of Technology, 2012, 332 p. Available at [ltu.diva-portal.org/](http://ltu.diva-portal.org/)

Puurula, Arto, Enochsson, O., Sas, G., Blanksvärd, T., Ohlsson, U., Bernspång, L., Elfgren, L. (2014): Loading to failure and 3D nonlinear FE modelling of a strengthened RC bridge. *Structure & Infrastructure Engineering*, 10(12), 1606-1619. 10.1080/15732479.2013.836546

Puurula, Arto, Enochsson, O., Sas, G., Blanksvärd, T., Ohlsson, U., Bernspång, L., Täljsten, B., Carolin, A., Paulsson, B., Elfgren, L. (2015): Assessment of the Strengthening of an RC Railway Bridge with CFRP Utilizing a Full-Scale Failure Test and Finite-Element Analysis, *J. Struct. Engineering*, ASCE, 2015, 141, D4014008, 11 p.

Puurula, Arto, Enochsson, O., Sas, G., Blanksvärd, Th., Ohlsson, U., Bernspång, L., Täljsten, B. and Elfgren, L. (2016): *3D non-linear FE analysis of a full scale test to failure of a RC Railway Bridge strengthened with carbon fibre bars*. 19th IABSE Congress Stockholm 21-23 September 2016: Challenges in Design and Construction of an Innovative and Sustainable Built Environment, Zürich, 2016, pp. 2527 – 2535. ISBN 978-3-85748-144-4. Available at <http://ltu.diva-portal.org/>

Rafols, J.C., Lau, K., Lasa, I., Paredes, M. & ElSafty, A. (2013): Approach to Determine Corrosion Propensity in Post-Tensioned Tendons with Deficient Grout. *Open Journal of Civil Engineering*, 2013, 2, 182-187, <http://dx.doi.org/10.4236/ojce.2013.33022>

Rehabcon (2004): Rehabcon Manual. Strategy for maintenance and rehabilitation in concrete structures. EC DG ENTR-C-2, IPS-2000, 145 pp. Available at [http://www.cbi.se/objfiles/1/MANUALmaindocum\\_1522366004.pdf](http://www.cbi.se/objfiles/1/MANUALmaindocum_1522366004.pdf) (Accessed 2015-06-20)

Reid, Iain Kennedy (2009): *Concrete Bridge Strengthening and Repair*. ICE Publishing, Telford, London, ISBN 978-0-7277-3891-2

Remington, P. J., Kurzweil, L. G., and Towers, D. A. (1987): Low-Frequency Noise and Vibration from Trains, ch. 16 from Transportation Noise Reference Book, ed. Nelson, P. M. Butterworth & Co. Ltd.

Ricketts, Nigel (2017); *Railway Bridge Maintenance*, 2<sup>nd</sup> Ed. London, ICE Publishing, 240 pp, ISBN 9780727760654

Sabourova, Natalia; Grip, Niklas; Tu, Yongming; Wang, Chao; Enochsson, Ola; Blanksvärd, Thomas; Nilsson, Martin; Ohlsson, Ulf and Elfgren, Lennart (2017): *Railway Concrete Arch Bridge over Kalix River at Långforsen. Dynamic Properties and Load-Carrying Capacity*. Research Report, Structural Engineering, Luleå University of Technology. To be available at <http://ltu.diva-portal.org/>

SB-D1.2 (2004): *European Railway Bridge Demography*. Deliverable D1.2 compiled by Brian Bell, Network Rail, in the Sustainable Bridges project, 15 pp. Available at the WP1 Section in <http://www.sustainablebridges.net/>

SB-D1.4 (2005): *Railway Bridge Research. An overview of current research carried out in the Sustainable Bridges project*. Deliverable D1.2 compiled by Luleå University of Technology in the Sustainable Bridges project, 44 pp. Available at the WP1 Section in <http://www.sustainablebridges.net/>

SB-D3.4 (2007): Condition assessment and inspection of steel railway bridges including stress measurements in riveted, bolted and welded structures. 94 pp. Background document D3.4 to SB-ICA *Inspection and Condition Assessment*. Prepared by Sustainable Bridges- a project within EU FP6. Available from: [www.sustainablebridges.net](http://www.sustainablebridges.net).

SB-D4.7.1 (2007): *Structural assessment of masonry arch bridges*. Background document D4.7.1 to “Guideline for Load and Resistance Assessment of Railway Bridges”. Prepared by Sustainable Bridges- a project within EU FP6. Available from: [www.sustainablebridges.net](http://www.sustainablebridges.net).

SB-D4.7.4 (2007): *Potentiality of probabilistic methods in the assessment of masonry arches*, Background document D4.7.4 to “Guideline for Load and Resistance Assessment of Railway Bridges”. Prepared by Sustainable Bridges- a project within EU FP6. Available from: [www.sustainablebridges.net](http://www.sustainablebridges.net).

SB-D6.2 (2007): *Repair and Strengthening of Railway Bridges. Litterature and Research Report.*, 807 pp. Available from: [www.sustainablebridges.net](http://www.sustainablebridges.net): Prepared by Sustainable Bridges - a project within EU FP6.

SB-D6.3 (2007): Field Tests. Örnköldsvik Bridge, Vitmossen, Frövi Bridge, 181 pp. Available from: [www.sustainablebridges.net](http://www.sustainablebridges.net): Prepared by Sustainable Bridges - a project within EU FP6.

SB-D6.4 (2007): Method statement guideline. *Workmanship and Quality Control of CFRP strengthened structures*, 74 pp. Available from: [www.sustainablebridges.net](http://www.sustainablebridges.net): Prepared by Sustainable Bridges - a project within EU FP6.

SB-D7.3 (2008): *Field Test of a Concrete Bridge in Örnköldsvik, Sweden*. Elfgrén L, Enochsson O, and Thun H. Deliverable D 7.3, Sustainable Bridges – Assessment for Future Traffic Demands and Longer Lives, see SB (2007). Available from: [www.sustainablebridges.net](http://www.sustainablebridges.net)

SB-ICA (2007): *Inspection and Condition Assessment*. Guideline developed in the EC-FP6 Project Sustainable Bridges, 259 pp; Available at [www.sustainablebridges.net](http://www.sustainablebridges.net)

SB-LRA (2007): *Load and Resistance Assessment of Railway Bridges*. Guideline developed in the EC-FP6 Project Sustainable Bridges 428 pp. Available at [www.sustainablebridges.net](http://www.sustainablebridges.net)

SB-MON (2007): *Guideline for Monitoring of Railway Bridges*, Guideline developed in the ECFP6 Project Sustainable Bridges, 93 pp. Available at [www.sustainablebridges.net](http://www.sustainablebridges.net)

SB-STR (2007): *Guide for use of Repair and Strengthening Methods for Railway Bridges*. Guideline developed in the EC-FP6 Project Sustainable Bridges, 139 pp. Available at [www.sustainablebridges.net](http://www.sustainablebridges.net)

SCB (2007): *Livslängden i Sverige 2001-2005. (Life length in Sweden)*. In Swedish with a summary in English), Statistiska Centralbyrån (Statistics Sweden), Stockholm 2007, 136 pp, see [http://www.scb.se/statistik/\\_publikationer/BE0701\\_2001I05\\_BR\\_BE51ST0701.pdf](http://www.scb.se/statistik/_publikationer/BE0701_2001I05_BR_BE51ST0701.pdf) (Accessed 2015-06-20)

Schneider, Jörg (1994): *Sicherheit und Zuverlässigkeit im Bauwesen. Grundwissen für Ingenieure*. (Safety in Civil Engineering. Basics for Engineers. In German) Unter Mitarbeit von Hans-Peter Schlatter. vdf Hochschulverlag AG an der ETH Zürich, 188p., ISBN 978-3-7281-2167-3. DOI 10.3218/2167-7,

Schneider, Jörg & Vrouwenvelder, Ton (2017): *Introduction to Safety and Reliability of Structures*. 3<sup>rd</sup> reviewed and extended Ed. (1<sup>st</sup> Ed. 1997). Structural Engineering Documents No 5, International Association for Bridges and Structural Engineering (IABSE), c/o ETH Zürich, Switzerland, 164 pp. ISBN 978-3-85748-131-2.

SIA 269 (2011): Existing structures – Bases for examination and interventions, Swiss Society of Engineers and Architects (SIA), Zurich. (in German and French).

SIA 269/1 (2011): Existing structures – Actions, Swiss Society of Engineers and Architects (SIA), Zurich. (in German and French)

Siwowski, Tomasz & Zóltowski, Piots (2012): Strengthening Bridges with Prestressed CFRP Strips. Journal of Civil Engineering. Volume 7, Issue 1, Pages 79–86, ISSN (Print) 1338-7278, DOI: [10.2478/v10299-012-0021-2](https://doi.org/10.2478/v10299-012-0021-2), March 2013

Sustainable Bridges (2008): *Sustainable Bridges – Assessment for Future Traffic Demands and Longer Lives*. A European Integrated Research Project during 2003-2008. Four guidelines and 35 background documents are available at [www.sustainablebridges.net](http://www.sustainablebridges.net)

Thun, Håkan; Ohlsson, Ulf and Elfgren, Lennart (2000): *Fatigue Capacity of Small Railway concrete Bridges. Prevision of the Results of Swedish Full-Scale Tests. Comparison and Analyses*. Final Report to the European Rail Research Institute, ERRI, D216/DT384, Luleå University of Technology, Division of Structural Engineering, 99 pp. Available at <http://ltu.diva-portal.org/>

Thun, Håkan (2006): *Assessment of Fatigue Resistance and Strength in Existing Concrete Structures*. Ph D Thesis 2006:65, Div. of Structural Engineering, Luleå University of Technology, 169 pp. ISBN 978-91-85685-03-5. Available at <http://ltu.diva-portal.org/>

TRVK Bärighet (2014): *Bärighetsberäkning av broar. Krav* (Rules for the assessment of bridges. In Swedish). Trafikverket TDOK 2013:0267, Version 4, 2017-02-20, 142 pp. Issued instead of BV-Bärighet (2012). Available at <http://trvdokument.trafikverket.se/Default.aspx>

TRVR Bärighet (2014): *Bärighetsberäkning av broar. Råd* (Recommendations for the assessment of bridges. In Swedish). Trafikverket TDOK 2013:0273, Version 4, 2017-02-20, 34 pp. Issued instead of BV-Bärighet (2012). Available at <http://trvdokument.trafikverket.se/Default.aspx>

UIC 702 (2003): *Static Loading Diagrams To Be Taken Into Consideration For The Design Of Rail Carrying Structures On Lines Used By International Services*. UIC Code 702, Ed. 3, 2003, International Union of Railways, Paris, 16 pp.

UIC 721 R (2013): Recommendation for use of rail steel grades. UIC Code 721 R, 2013, International Union of Railways, Paris.

UIC 778-1 (2011): *Recommendations for the consideration of fatigue in the diagonal steel railway bridges, especially with orthotropic decks*. UIC Code 778-1 R, 3rd Ed, Nov 2011, International Union of Railways, Paris, 14 pp.

UIC 778-2 (1986): *Recommendations for determining the carrying capacity of existing metal bridges*. UIC Code 778-2 R, 1st Ed, July 1986, International Union of Railways, Paris, 57 pp.

UIC 778-3 (2014): *Recommendations for the inspection, assessment and maintenance of masonry arch bridges*. UIC Code 778-3 R, 3<sup>rd</sup> Ed., International Union of Railways, Paris, 167 pp.

UIC 778-4 (2009): *Defects in railway bridges and procedures for maintenance*. UIC Code 778-4 R, 2nd Ed., International Union of Railways, Paris, 32 pp.

Wang, C., Wang, Z., Zhang, J., Tu, Y., Grip, N., Ohlsson, U., & Elfgren, L. (2016): "FEM-based research on the dynamic response of a concrete railway arch bridge." 19th Congress of IABSE Stockholm 2016: Challenges in Design and Construction of an Innovative and Sustainable Built Environment, International Association for Bridge and Structural Engineering (IABSE), Stockholm, Sweden, 2472-2479. Available at <http://ltu.diva-portal.org/>

Zilch, Konrad; Niedermeier, Roland and Finckh, Wolfgang (2014): *Strengthening of Concrete Structures with Adhesively Bonded Reinforcement. Design and Dimensioning of CFRP Laminates and Steel Plates*. Berlin: Ernst & Sohn, Wiley, 148 pp, ISBN 978-3-433-03086-8. The original German text was published in Betonkalender 2013.

## 6. Tunnels

According to Table 3.1 it is mostly the need for a greater loading gauge that influences the upgrading of tunnels. The loading gauge defines the maximum height and width for railway vehicles and their loads to ensure safe passage through tunnels. A clearance is added to the loading gauge to obtain the structural gauge (also called the minimum clearance outline).

Below some guidelines are given. A general handbook on tunnels is Maidl et al (2013, 2014). More material can be found in ML-D1.2 (2014) and in UIC-779-9 (2003), UIC-779-10 (2011), UIC 779-11 (2005) and Ramondenc & Beaume (2004). There is also a special working group on “Tunnel Redevelopment”, organized by STUVA (Studiengesellschaft für unterirdische Verkehrsanlagen mbH, Research Association for Underground Transportation Facilities Ltd), see Simon (2012).

### 6.1 GENERAL ASPECTS

Basic tunnel sections for different subgrades are outlined in Figure 6.1



	<p><b>Rectangular</b></p> <p>Used when the external forces do not lead to any damaging movement of the rock mass into the tunnel.</p>
	<p><b>Semi-elliptical, parabolic or semi-circular</b></p> <p>Used when vertical forces act.</p>
	<p><b>Horseshoe, vaulted</b></p> <p>Used when horizontal and vertical forces act.</p>
	<p><b>Circular</b></p> <p>Used when forces act from all sides and particularly with internal water pressure.</p>

FIGURE 6.1. BASIC TUNNEL SECTIONS FOR DIFFERENT SUBGRADES. MAIDL ET AL (2014).

Tunnels can be either lined or unlined and have a variety of shapes as illustrated in Figure 6.2.

The material used to line tunnels can be masonry (either stone or brick), in situ concrete, precast concrete segments or metallic (cast iron or steel) segments and each presents its own challenges when life extension is being considered.

As most railway tunnels date back to the 19<sup>th</sup> century they were inevitably constructed using hand tunnelling techniques, which usually required the construction of vertical access shafts from ground level. In some cases, these shafts were left open to provide ventilation but others were backfilled and are referred to as buried or hidden shafts whose location is often unknown. Shafts are discussed in ML-D1.3 (2015).

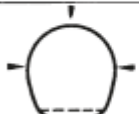
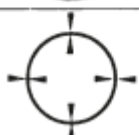
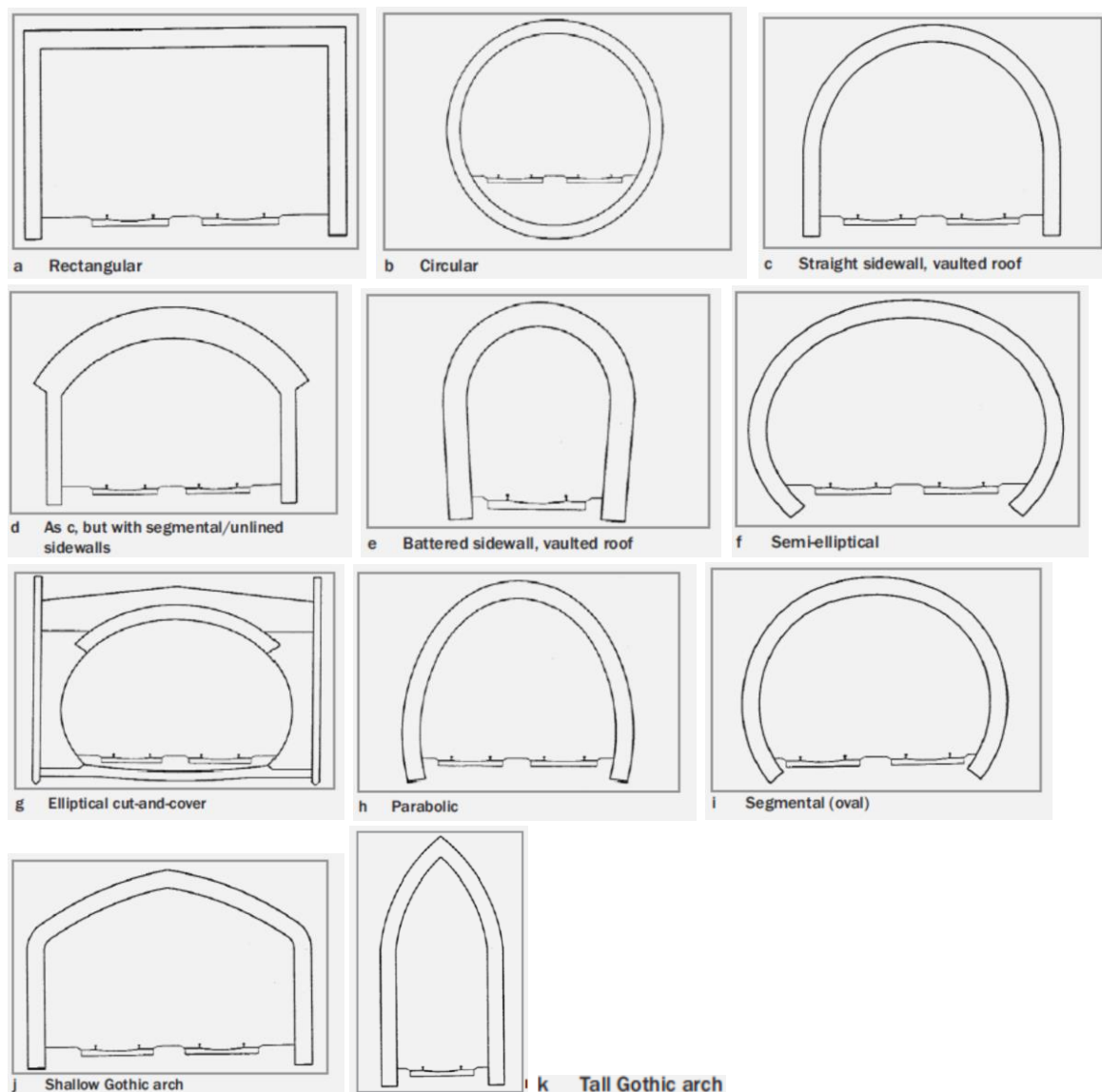

FIGURE

6.2. TYPICAL UK TUNNEL CROSS SECTIONS, RAILTRACK (1966)

The upgrading of a railway line to higher axle loads usually does not present any problems for tunnels as the sub ground mostly has a high load-carrying capacity. However, if there is a need to increase the tunnel profile, a major challenge is at hand. Then the present profile must be enlarged and this may lead to new drilling and blasting in the same way as when a new tunnel is constructed. Maidl et al (2013, 2014) give guidance for construction in the aforementioned handbooks.

Some standard loading gauges are shown in Figure 6.3. The European Rail Agency (ERA) in its Technical Specifications for Interoperability (TSI) has defined a number of recommendations to harmonize the train systems. The TSI Rolling Stock (2002/735/EC) has taken over the UIC Gauges definitions defining

Kinematic Gauges with a reference profile such that Gauges GA and GB have a height of 4.35 m (they differ in shape) with Gauge GC rising to 4.70 m allowing for a width of 3.08 m of the flat roof. All cars must fall within an envelope of 3.15 m wide on a 250 m radius curve. The French high speed trains (TGVs), which are 2.9 m wide, fall within this limit. The designation of a GB+ loading gauge refers to the plan to create a pan-European freight network for ISO containers and trailers with loaded ISO containers, UIC 506 (2008).

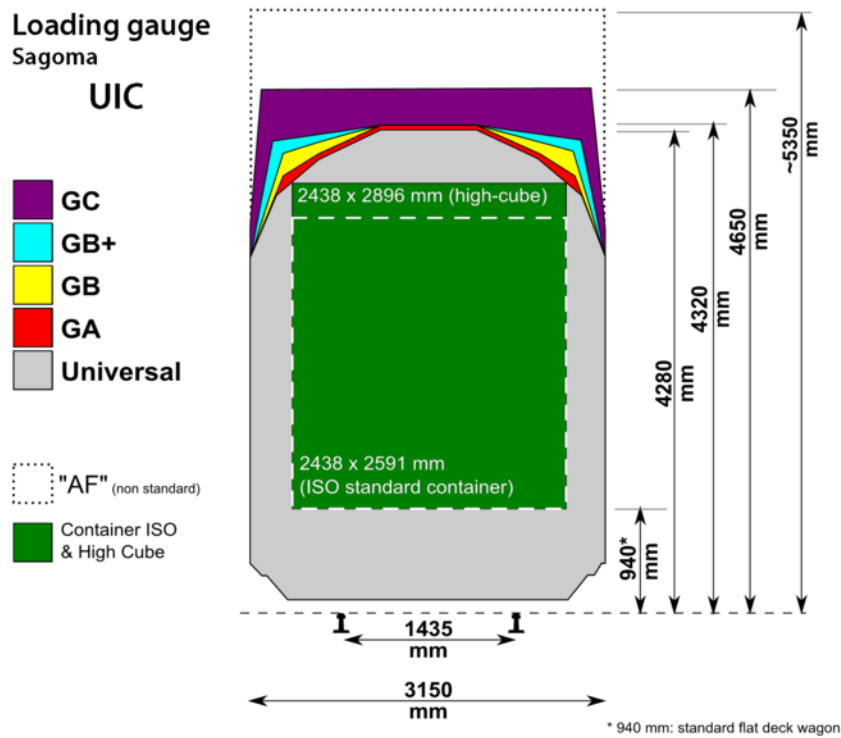

FIGURE 6.3. DIFFERENT LOADING GAUGES AND A STANDARD ISO CONTAINER. UIC 506 (2008).

Technical possibilities for the STUVA group on Tunnel Rehabilitation studies working in tunnels with rail services in operation, see Table 6.1



TABLE 6.1. TECHNICAL POSSIBILITIES FOR WORKING IN TUNNELS WITH RAIL SERVICES IN OPERATION. SIMON (2012)

Work in tunnel*	operational without closure times			operational with closure times		
	Single-track tunnel	2-track tunnel		Single-track tunnel	2-track tunnel	
		Alternating track operation	Conversion to 1-track in tunnel for construction period		Alternating track operation	Conversion to 1-track in tunnel for construction period
<b>Vault support</b>						
Mining means						
Support plate against caving						
<b>Redeveloping vault and local enlargements</b>						
Adapting clearance profile						
Improving the vault						
<b>Vault enlargement</b>						
Removing the vault						
<b>Enlarging tunnel in rock</b>						
Mining means possibly blasting			TIT			TIT
<b>Vault support</b>						
1-layer						
2-layer						
Segment lining						
State of technology/references available			Future application feasible			

\* The restrictions and regulations in conjunction with the overhead line must be checked separately in the case of electrified routes!

## 6.2 WORK PROCESS

As part of the process of determining the need to undertake life extension of a tunnel, it is sometimes necessary to undertake a structural assessment. This will follow similar lines to that adopted for bridges constructed of the same basic engineering material and can include the advanced techniques described in chapter 5 of this guideline.

### 6.2.1 ASSESSMENT OF TUNNELS

The deterioration of unlined tunnels is usually limited to failures of the rock through which the tunnel is driven, often caused by ground water permeation or the effect of frost. This can vary from the regular loss of small pieces from friable rock to the dislodgement of blocks of stone, which could be large enough to derail a train as shown in Figure 6.4. The potential for the latter type of failure is largely dependent on the orientation of the bending planes within the rock mass.

Life extension measures are largely traditional and can consist of (based on McKibbins et al (2009));

- Scaling of loose material or the removal of loose blocks
- Provision of protection shelters

- Localised rock bolting
- Rock bolting and rock fall protection mesh
- Localised application of sprayed concrete to support weak areas of rock
- Installation of supporting ribs
- Installation of full lining, usually using sprayed concrete

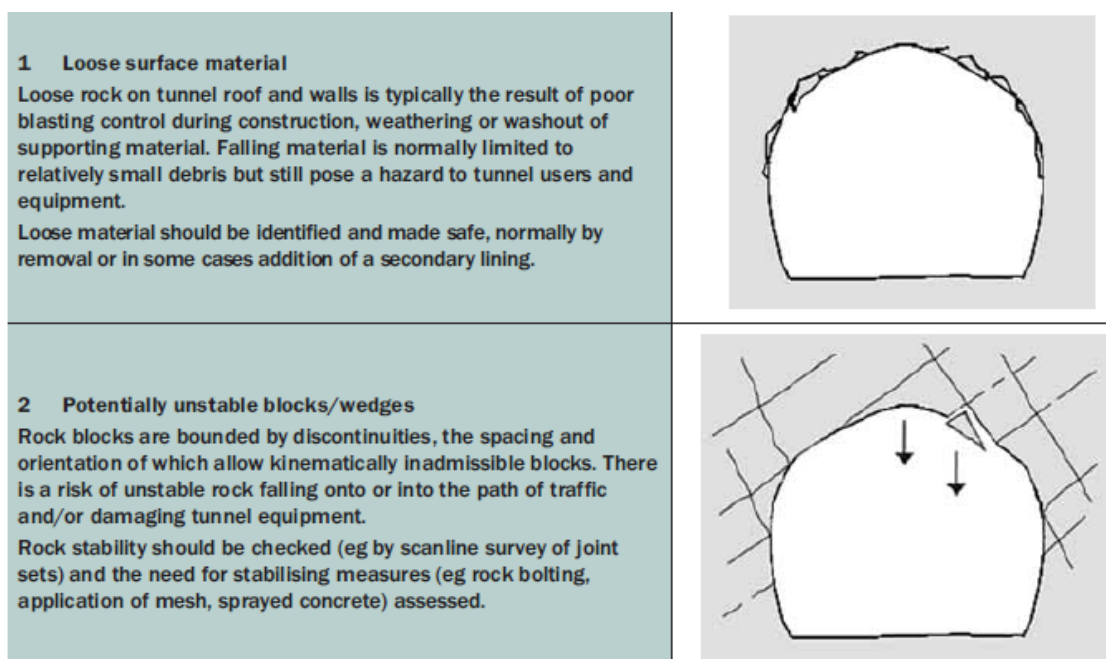

FIGURE 6.4. DEFECTS IN UNLINED TUNNELS .CIRIA C671, MCKIBBINS ET AL (2009)

## 6.2.2 EXTENSION OF LINED TUNNELS

### MASONRY

The deterioration of masonry in tunnel linings is very similar to the deterioration of masonry in arch bridges and can be due to:

- Freeze thaw action
- Salt attack
- Sulphate attack
- Leaching of mortar
- Biological attack
- Use of unsympathetic repair material
- Thermal effects
- Saturation
- Ground movement

- Fatigue

These deterioration mechanisms usually manifest themselves as spalling of the masonry lining, cracking of the masonry lining or loose masonry caused by loss of mortar.

Traditional repair/life extension techniques usually consist of:

- Patch repairs
- Crack repairs
- Ring separation repair
- Grouting
- Underpinning
- Invert repair

New support systems have been developed, which can be left in situ permanently. One example is shown in case study 2 in Appendix C in ML-D1.3 (2014).

Examples of action that can be taken includes reinforcement, injection, recessing and inset of shells, see Figure 6.5., Ramondenc & Beaume (2004).

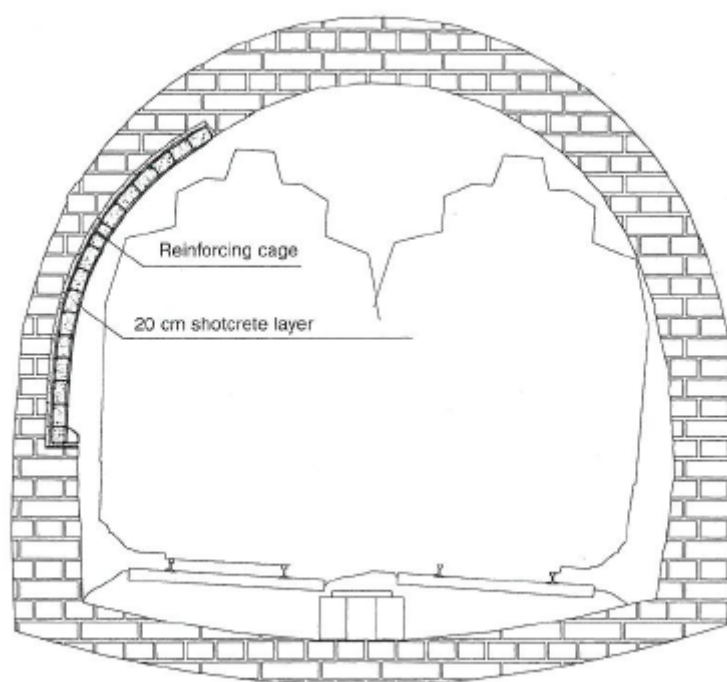

**FIGURE 6.5 CROSS SECTION OF A RECESSED TUNNEL, RAMONDENC & BEAUME (2004)**

In a recent project, Upgrading (2016), the works on a tunnel vault is divided into four types, A-D depending on the overlapping length, see Figure 6.6. An example is given on how a roadbed can be lowered, see Figure 6.7.

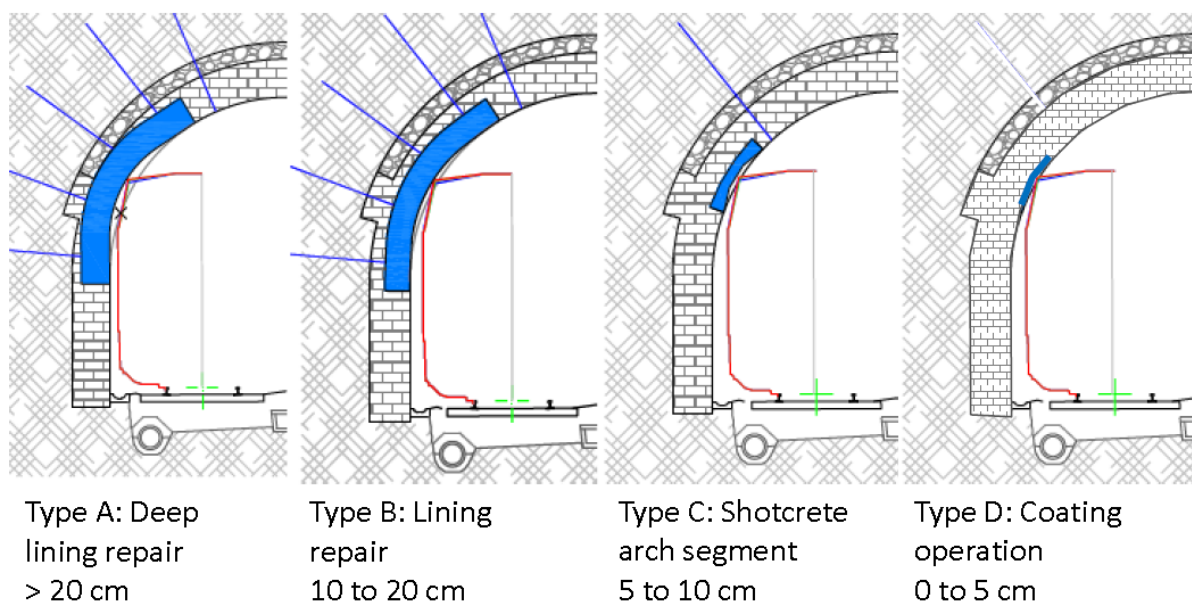
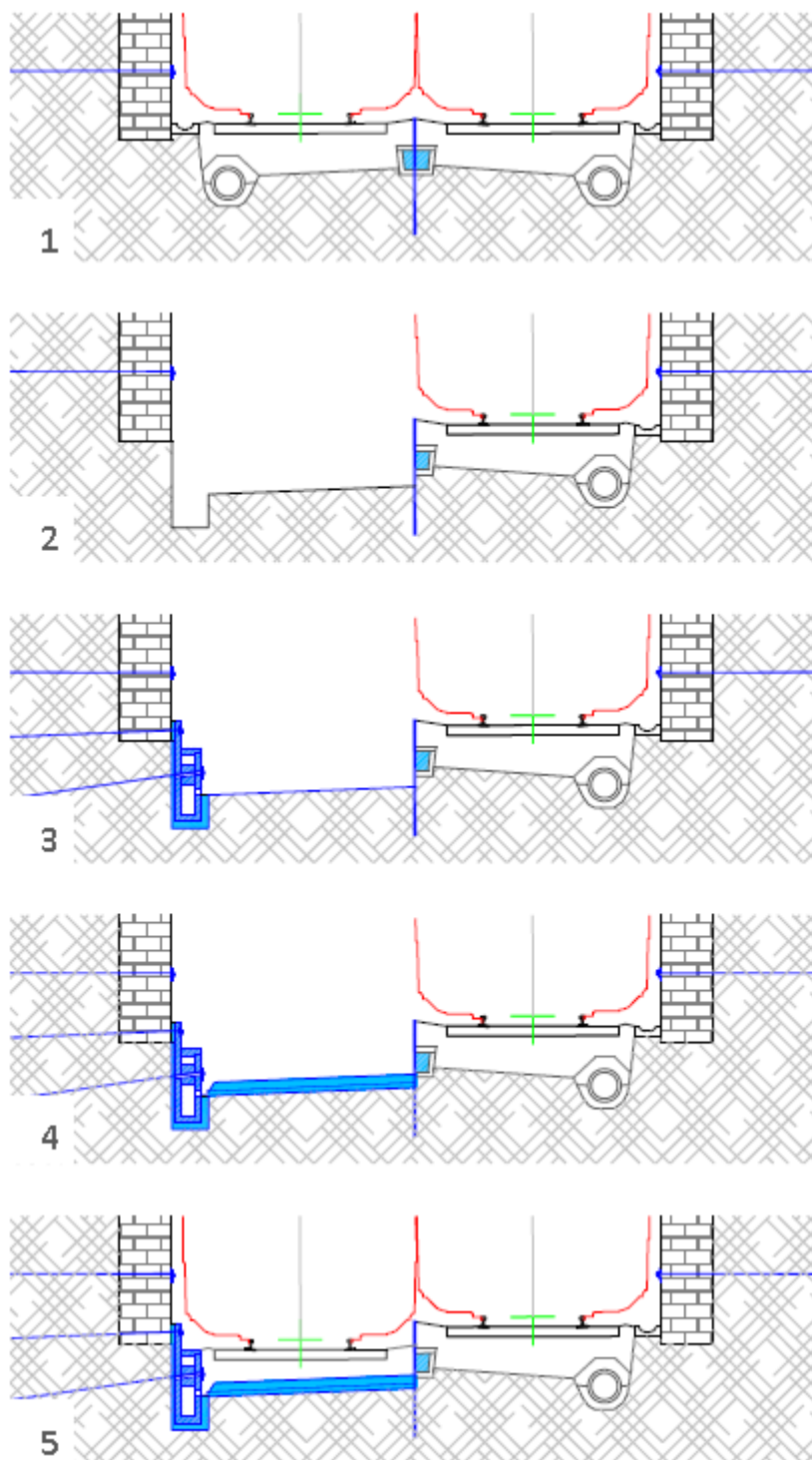

FIGURE 6.6. FOUR TYPES OF WORKS ON A TUNNEL VAULT, SEE UPGRADING (2016).

In the Report Upgrading (2016), an assessment also presents the practices of the infrastructure managers concerning their management of the clearance gauge: knowledge of the actual gauge using measurements, procedures implemented in response to requests from railway undertakings, monitoring of the infrastructure information and communication of this information to customers, in particular via the Network Statements. A Best Practice Guide presents recommendations in terms of regulations, based on these assessments, in order to smoothen interactions between the different stakeholders, to facilitate access to the rail network by customers and ultimately to develop rail freight business.



**FIGURE 6.7. PROCESS DESCRIPTION FOR LOWERING OF A ROADBED: 1. PRELIMINARY WORKS: SIDEWALLS ANCHORING; 2. RAILWAY LINE DISMANTLING AND UNDERPINNING EXCAVATION; 3. LATERAL ANCHORS GUTTERING; 4. SEWAGE SYSTEM IMPLEMENTATION; 5. RAILWAY LINE INSTALLATION, SEE UPGRADING (2016).**

#### IN SITU CONCRETE LININGS

---

In situ concrete linings usually suffer from similar deterioration mechanisms as other forms of concrete structure (principally carbonation or chloride-induced corrosion) and the repair methods generally follow traditional lines. Advice on how to ensure quality repairs can be found in numerous publications and research project outputs; one example is the manual from the European project, Rehabcon (2004).

More recently the use of both steel and carbon fibre to strengthen tunnel linings has started to become accepted, particularly in Japan. Details of one steel system can be found in Nippon (2005) and details of carbon fibre strengthening can be found in Karbhari (1998).

#### CONCRETE SEGMENTS

---

Tunnels lined with concrete segments mostly have to be rebuilt. A detailed engineering assessment will be needed before deciding on the correct action.

A new lining will be necessary. This can be undertaken either by the installation of replacement segments or by the use of sprayed concrete and – although expensive – can be carried out in very short lengths during overnight closures of the tunnel.

#### METALLIC SEGMENTS

---

Metallic segments can be manufactured out of either steel or cast iron and are usually only to be found in circular tunnels. The most common defects are cracking (in general only at boltholes) and corrosion. Steel linings can be repaired by welding or bolting new steel into position but cracked cast iron should be repaired using stitching. Corrosion in general affects steel linings. They should therefore be treated using conventional surface coating techniques.

There is at least one example of the replacement of cast iron segments with cast stainless steel segments in an area where sulphuric acid was present in the ground water (reported in Appendix A1.9 of CIRIA C671, McKibbins et al (2009)). The solution has been designed for a 400-year life and, whilst expensive, was deemed to be the only practical solution in this particular case.

Three case studies are presented in Appendix C in ML-D1.3 (2015).

## 6.3 CONDITIONS AND EXAMPLES FROM DIFFERENT COUNTRIES

### 6.3.1 GERMANY

In Germany, see Simon (2012), the DB AG is obliged to follow the data given by the EBO (ordinance regulating the construction and operation of the railways) to enlarge the track distance from in some cases only 3.5 m up to 4.0 m for new tracks and extensive upgrading projects. Widening the track

distance results in part in protracted construction measures, which can be made even more difficult by having to renew the floor. As a result, the so-called tunnel-in-tunnel (TIT) method was applied for the first time when redeveloping the Jährod and Mausenmühlen tunnels, see Figure 6.8.

When renovating tunnel structures in excess of 1,000 m the new tunnel must be produced with 2 bores for such total redevelopments or renovations to comply with the regulations now laid down in the valid safety guidelines. This signifies the construction of a new single-track bore parallel to the existing one, which must be renewed through transforming it from a twin-track to a single-track tunnel. These 2 tunnels are then connected every 500 m with cross-passages for evacuation purposes.



FIGURE 6.8. JÄHROD TUNNEL IN GERMANY BEING ENLARGED BY THE TUNNEL-IN-TUNNEL (TIT) METHOD, SIMON (2012).

### 6.3.2 AUSTRIA

There are numerous new tunnels being built or planned in Austria as well, Simon (2012). These include some 350 km of mainline tunnels including the Brenner Base Tunnel with a total driven length of roughly 110 km. Redevelopment measures devised to improve the substance such as in the Arlberg Tunnel or the Tauern Tunnel also take place against the background of improving safety technology. The measures to enhance “Tunnel Safety” were triggered some 10 years ago – owing to the fire

incidents in the Mont Blanc road tunnel (March 1999), in the Tauern motorway tunnel (May 1999) and in the Channel Tunnel (November 1996).

Austria's regulations designed to protect the workforce represent a further source for modifying and partial redevelopment of old tunnels.

### 6.3.3 SWITZERLAND

In Switzerland the floor is frequently renovated on account of damage resulting from drainage and heaving rock formations, in many cases also in conjunction with lowering the floor to adjust the cross-section for future piggyback transportation. In the case of twin-track tunnels, it is also necessary to install a ballast retention system to secure the operational track, Simon (2012).

### 6.3.4 SWEDEN

Sweden has since the seventies allowed special transports. These transports had both heavier loads and larger loading gauges than standard ones. In 1990, a special program was developed called LÖ90. To this end, positions and geometry of all obstacles were accurately measured according to a Swedish code called FOMUL-measuring. In the code all existing obstacles were defined. It was also defined how often they should be controlled and measured. All special transports had to have a special permission. This was carried out during many years and gave SJ Freight good profits.



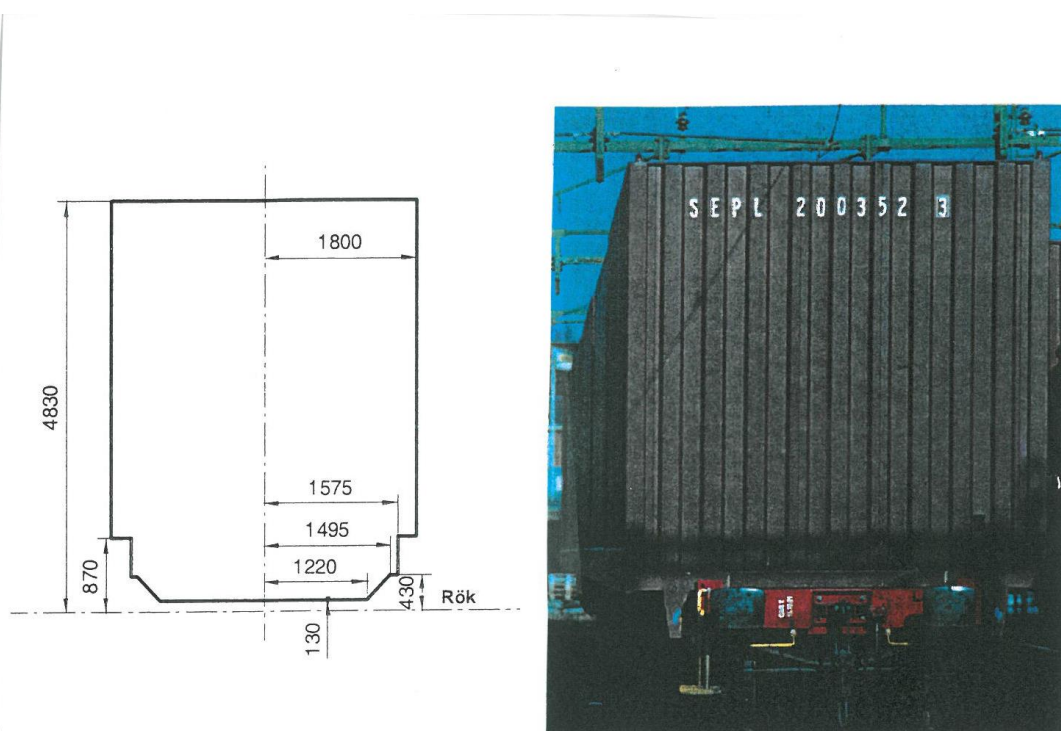

FIGURE 6.9. SWEDISH LOAD PROFILE C (LEFT) AND A PICTURE OF THE BIG BOX.

When discussion in 1998 started with Stora Enso they wanted to have both higher axle loads and larger loading gauges. Since Banverket had good control over the situation from working with LÖ90, Stora Enso was allowed to operate the “Stora Boxen” (the "big box") on some lines starting late 1999, Figure 6.9.

Today more than 25% of the net is upgraded with load profile C. The cost for upgrading is very dependent on the specific local circumstances. The costs to investigate and if necessary to move obstacles was on average 10 k€ per kilometre. The main problem was the clearance pole at meeting stations that was very expensive to move. This problem was therefore solved by putting an empty wagon with a standard load profile at the end of the train.

During the investigation and FOMUL-measuring, it was noticed that three tunnels were not within load profile C. For one of them it was enough with small measures and some upgrading of the catenary system. For the other two a lowering the level of the track was necessary. All work had to be carried out during vacation time in 1999. An important experience was that logistics work has to be well planned. Additional costs compared with budget were 12% which is low in Swedish tunnel-contracts.

### 6.3.5 USA

One example of a cross section expansion is the Weehawken tunnel built 1881–1883 by the New York West Shore Railroad. The original rail freight tunnel had a width by height section of 8.4 x 6.4 m and it was in 2004–2006 enlarged to 19.7 x 10.4 m. The tunnel has a length of 1.25 km, had originally a semi-elliptical arched roof with nearly vertical walls, and was constructed for two tracks with a 4-m centerline distance. The majority of the tunnel was constructed in the rock of the Palisades Diabase. For approximately three-quarters of its length, the tunnel was unlined and the natural rock exposed. Eight sections of the tunnel were lined with brick masonry, see figure 6.3.3.

The geometrical requirements of the new tunnel cross-sections were established taking into consideration the dynamic clearance envelope of the light rail vehicle; system and catenary clearances; construction tolerances; a maintenance walkway; presence of the existing utility duct banks and need for their uninterrupted service in all phases of construction; requirements of minimizing the excavation quantities; and the tunnel ventilation requirements. Different “modified horse-shoe” shaped cross-sections were identified for the unlined sections and fully lined sections of the tunnel resulting in a new width by height section of 19.7 x 10.4 m, Berliner et al (2004). New concrete walls were added to decrease the risk of spalling, especially in the case of fire. A special mix was created with polypropylene fibers to form cast-in-place concrete walls in the station and in areas that did not already have the tunnel’s original brick arch and masonry sidewalls. Another mix was created for the drainage and waterproofing system. Here shotcrete (a high-powered spray application of concrete) was used for the liner at station-to-tunnel transitions and for the arched lining at the river portal. The new tunnel is shown in Figure 6.10.



**FIGURE 6.10. THE WEEHAWKEN TUNNEL IN NEW YORK WAS IN 2006 WIDENED FROM 8.4 x 6.4 M TO 19.7 x 10.4 M, SEE BERLINER ET AL (2004). PHOTOS BY JOHN PAPAS 2004 AND DAVID PIRMAN 2006.**

## 6.4 REFERENCES

Berliner, Harvey L.; Campo, David W.; Dickerson, Charles N.; and Mack, Glenn (2004): Design and Construction of the Weehawken Tunnel and Bergenline Avenue Station for the Hudson–Bergen Light Rail Transit System. Transportation Research Circular E-C058: 9th National Light Rail Transit Conference, Transportation Research Board, U.S. pp 389-406. Available at:

---

<http://onlinepubs.trb.org/onlinepubs/circulars/ec058.pdf> Additional information at  
<http://www.subwaynut.com/hblr/weehawkent/> <http://www.nycsubway.org/perl/show?53650>

CIRIA C671 (2009): *Tunnels: Inspection, assessment and maintenance*. London: CIRIA Publication C671.  
Authored by McKibbins, L., Elmer, R. and Roberts, K. ISBN 9780860176718

MAINLINE (2014): *A European Community 7<sup>th</sup> Framework Program research project with the full title: MAINTenance, renewal and Improvement of rail transport iNfrastructure to reduce Economic and environmental impacts*. Research Project 2011-2014 with 19 partners. Grant agreement 285121, SST.2011.5.2-6. Dr. Björn Paulsson, UIC/Trafikverket acted as Project Coordinator. A project summary and 27 deliverables and can be downloaded from [www.mainline-project.eu](http://www.mainline-project.eu)

Maidl, Bernhard, Thewes, Markus, Maidl, Ulrich and Sturge, David S (2013): *Handbook of tunnel engineering*. Vol. 1, Structures and methods, Wiley, 482 pp, ISBN: 978-3-433-03048-6

Maidl, Bernhard, Thewes, Markus, and Maidl, Ulrich (2014): *Handbook of tunnel engineering*. Vol. 2, Basics and additional services for design and construction, Wiley, 458 pp, ISBN: 978-3-433-03049-3

McKibbins, L., Elmer, R., Roberts, K. (2009): *Tunnels: Inspection, assessment and maintenance*. CIRIA C671, London 2009, 36 pp.

Nippon (2005): *Structure and Construction Examples of Tunnel Reinforcement Using Thin Steel Plates*. Authored by Kazuakaki Kiriya et al. Nippon Steel Report, No 92, July 2005, 6 pp. Available at <http://www.nssmc.com/en/tech/report/nsc/pdf/n9209.pdf> (Accessed 2015-06-20)

Railtrack 1996 – *Guide to tunnel management* (unpublished internal guidance document)

Ramondenc, Philippe and Beame, Ariane (2004): *Railway tunnel maintenance*. Rail International, Schienen der Welt, June/July 2004, Vol 35, p 36- 40,

Simon, Stefan (2012): *Report on Redeveloping Railway Tunnels*. *Tunnel*, No 4, 2012, pp 26-37.  
Available at [http://www.tunnel-online.info/download/455400/2012\\_04\\_Sachstandsbericht\\_Sanierung\\_von\\_Eisenbahntunneln.pdf](http://www.tunnel-online.info/download/455400/2012_04_Sachstandsbericht_Sanierung_von_Eisenbahntunneln.pdf).  
See also “Nachrüstung von Eisenbahntunneln: Bedarf und jüngste Erfahrungen” (Redevelopment of Tunnels. In German).ppt presentation, DB NETZE. Available at [http://www.tlb.rub.de/mam/images/03\\_simon.pdf](http://www.tlb.rub.de/mam/images/03_simon.pdf)

Upgrading (2016): *Measuring and upgrading the clearance gauges of railway lines*. Presentation at final dissemination meeting, Dec 2016, in a European project with participation from UIC, FRET,

Captrain, HUPAC, SYSTRA, SNCF, COMSA, adif and Infrabel. Final Report, November 2016,  
100+91pp.. see [https://ec.europa.eu/transport/modes/rail/studies/rail\\_en](https://ec.europa.eu/transport/modes/rail/studies/rail_en)

---

## 7. Culverts

---

### 7.1 GENERAL ASPECTS

According to Table 3.2 it is mostly a higher axle load that influences the use of culverts.

Culverts compared with bridges are often not well documented and maintained. Of course, this differs in different countries.

Guidelines and a handbook for assessment and repair of culverts have been issued by UIC and Trafikverket, see Södergren (2011) and TRVH Avvattning (2011). E.g. FHWA (2000) and Balkham (2010) have published general design guides for culverts.

### 7.2 WORK PROCESS

#### 7.2.1 CURRENT SITUATION

Pipes and culverts have different cross sections and can be built up in various ways. They can for instance be square, rectangular, circular, arch shaped and be made of separate parts or just one unit, see Figure 7.1.



FIGURE 7.1. DIFFERENT TYPES OF CULVERTS, SÖDERGREN (2011)

When the railway was new, many culverts were made with a square or rectangular cross section piled up with blocks of rock like masonry. Today's culverts are often pipes with a circular cross section and often made in sections, although they can also be in a single unit. Common materials for circular culverts made of sections are concrete, steel or plastic while those of one unit normally are made of plastic or steel. In recent years arch shaped culverts made of precast concrete with an interlocking effect have been introduced on the market.

Depending on how the pipes and culverts are designed and what materials they consist of they are susceptible to different types of damage.

Each buried pipe or culvert is subjected to loads that cause stresses in the walls. Some of these loads can be calculated. Others that can cause problem are not easy to calculate.

#### **Loads that can be calculated**

- Earth fill above;
- Traffic load.

#### **Loads that cannot be calculated easily**

- Elongation of pipes and culverts under deep fill,
- Settlement in the foundation,
- Frost heave,
- Lack of lateral support due to insufficient compaction in the surrounding soil,
- Restraints caused by for example manholes,
- Thermal effects.

The UIC group Panel of Structural Experts (PoSE) discussed the use of Pipes and Culverts and the requirements concerning design and installation methods and made a survey in 2009. Eighteen Rail Administrations answered a questionnaire and the result showed that there is a great difference in practices, Södergren (2011).

Some examples of the result are summarized below

#### **- Material accepted**

Reinforced concrete is accepted in all countries, steel in all except one, concrete in 10 and fibre glass in 7 countries. Corrugated steel pipes are used in 9 countries. Other materials mentioned are plastics and stone.

#### **- Minimum depth under track**

The minimum depth varies between 0.55 m and 2.2 m

#### **- Angle between track and pipe**

7 countries require 90°, other minimum angles mentioned are 80° – 30°, 4 countries have not required any minimum angle.

#### **- Maximum diameter of pipe allowed without a static calculation**

10 countries require calculation in all cases; the other 8 countries have given a diameter above which calculation is needed.

#### **- Traffic load**

Dynamic factor applied to the classic Load Model UIC 71 varies between 1.0 and 1.67

#### **- Fatigue**

4 countries are requiring fatigue checks.

#### **- Foundation**

6 countries have a special regulation for the foundation.

**- Back fill**

15 countries have regulation for back fill and compaction work.

### 7.2.2 . DAMAGE AND MALFUNCTION

Many old culverts have barrels built by boulders forming both walls and roof. With increased axleloads, the boulders may separate, which causes sand from the bank on top of the culvert to pour down into the culvert. This and other examples of damage are illustrated in Figure 7.2.



**FIGURE 7.2. EXAMPLES OF DAMAGES IN CULVERTS (FROM TOP LEFT CLOCKWISE): (A) CRACKING AND DOWNFALL OF BANK MATERIAL; (B) ICE CLOGGING THE CULVERT; (C ) CRATER IN BANK DUE TO DOWNFALL OF MATERIAL INTO CULVERT; (D) EROSION ALONG BANK. TRVH AVVATTNING (2011).**

## 7.3 EXAMPLES

Examples on measures to restore culverts are given in Figure 7.3. If only small deformations appear, a possibility is also to protect the culvert with a fiberglass lining. After cleaning the culvert, the lining can be inserted and hardened by ultra violet light.



**FIGURE 7.3. EXAMPLES OF MEASURES TO RESTORE CULVERTS (FROM TOP LEFT CLOCKWISE): (A) LINING WITH PLASTIC MATERIAL; (B) REPAIR OF JOINTS; (C) EXTENSION OF CULVERT; (D) CORRUGATED STEEL CULVERT REPAIRED WITH GLASS FIBRE LINING. THE LINING EXPANDS AT THE ENDS OF THE CULVERT AND STABILIZES THE EMBANKMENT. SÖDERGREN (2011), RAILCARE (2012), ML-D1.1 (2013).**



**FIGURE 7.4. LEFT: OLD STONE CULVERT WHERE THE BOULDERS HAVE SEPARATED AND SAND AND MUD HAVE POURED DOWN. RIGHT: A CULVERT IS KEPT TOGETHER BY POST-TENSIONING OF STEEL BARS SJÖBERG ET AL (1998), TRVH AVVATTNING (2011).**



The problem with separation of blocks has been analysed by Sjöberg et al (1998). The recommendation was to keep the culvert together with post tensioning with steel bars, see Figure 7.4.

## 7.4 REFERENCES

FHWA (2001); *Hydraulic Design of Highway Culverts*. Publication No FHWA-NHI-01-020, U.S.

Department of Transportation, Federal highway Administration, Hydraulic Design Series Number 5, Revised May 2005, 368 pp. Available at <http://isddc.dot.gov/OLPFiles/FHWA/012545.pdf>

MAINLINE (2014): *A European Community 7<sup>th</sup> Framework Program research project with the full title: MAINTenance, renewal and Improvement of rail transport iNfrastructure to reduce Economic and environmental impacts*. Research Project 2011-2014 with 19 partners. Grant agreement 285121, SST.2011.5.2-6. Dr. Björn Paulsson, UIC/Trafikverket acted as Project Coordinator. A project summary and 27 deliverables and can be downloaded from [www.mainline-project.eu](http://www.mainline-project.eu)

Railcare (2012): *Lining. Culvert refurbishment without traffic interruptions*. Railcare, Skelleftehamn, Sweden.

Sjöberg, Jonny; Nordlund, Erling; Olofsson, Eleonor (1998): *Numerisk modellanalys av stentrummor* (Analyses of culverts made of rectangular boulders. In Swedish). Technical Report 1998:15, Luleå University of Technology, 129 pp.

Södergren, Ingrid (2011): *Feasibility study on pipes and culverts*. UIC, International Union of Railways. Panel of Structural Experts, Swedish Geotechnical Institute, SGI, .32 pp. ISBN 978-2-7461-1874-4. Available at [ftp://ftp.swedgeo.se/!SGIARE/ingsod/Till%20diariet/Uppdrag%2014305%20Trummor%20och%20ledning%20Pipes%20and%20Culverts%20Feasibility\\_Study%2020110825.pdf](ftp://ftp.swedgeo.se/!SGIARE/ingsod/Till%20diariet/Uppdrag%2014305%20Trummor%20och%20ledning%20Pipes%20and%20Culverts%20Feasibility_Study%2020110825.pdf)

TRVH Avvattning (2011): *Tillståndsbedömning av avvattningsanläggningar. Bedömning av skador och förslag till åtgärder*. (Assessment and repair of pipes and culverts. In Swedish). Trafikverket Handbok BVH 1585.004, Edited by Magnus Karlsson, 105 pages. A ppt presentation is available at [http://www.vegvesen.no/\\_attachment/365697/binary/629043?fast\\_title=Truminventering+med+%C3%A5tg%C3%A4rdsf%C3%B6rslag.pdf](http://www.vegvesen.no/_attachment/365697/binary/629043?fast_title=Truminventering+med+%C3%A5tg%C3%A4rdsf%C3%B6rslag.pdf)

## 8. Retaining walls

### 8.1 GENERAL

Retaining walls are structures designed to restrain soil to unnatural slopes. They are used to bound soils between two different elevations often in areas of terrain possessing undesirable slopes or in areas where the landscape needs to be shaped severely and engineered for more specific purposes like hillside farming or roadway overpasses. Various types of retaining walls are illustrated in Figure 8.1 see e.g. Terzaghi et al. (1943, 1996). The rail can be situated either on the top, to the left of the wall, or to the right of the wall. The stability of the wall is the main design criteria especially if the rail is situated on the top of the wall. It is also important to keep enough space free for the train, compare with gauges for tunnels.

Table 3.1 indicates that increased meter and axle loads have the highest influence on retaining walls.

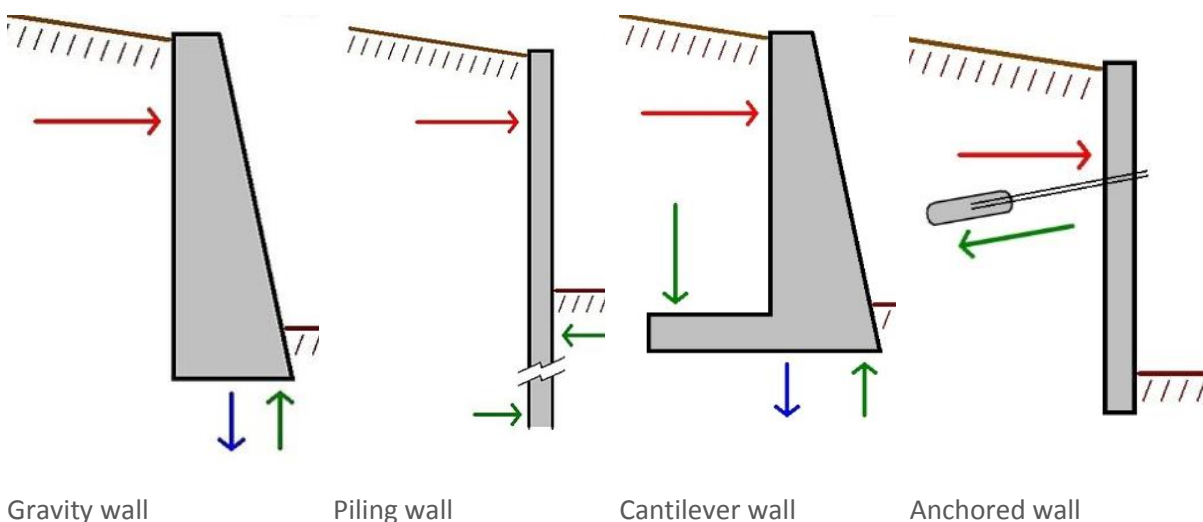

FIGURE 8.1. VARIOUS TYPES OF RETAINING WALLS. THE RAIL CAN BE SITUATED EITHER ON THE TOP, TO THE LEFT OF THE WALL OR TO THE RIGHT OF THE WALL INGOLFSON (2007)

Problems related to degradation of Earthwork and retaining walls are treated in ML-D1.4 (2014). In SR-D3.2 (2014) tests with geotextiles are presented to improve the subgrade of a railway line in Slovenia.

### 8.2 WORK PROCESS

The work process of constructing a retaining wall is mostly a question of guaranteeing a stable substructure, see Chapter 4

### 8.3 EXAMPLES

Retaining walls made of cages of stones, so called gabion retaining walls, are techniques that are common for highways and also used for railways, see Figure 8.2. A *gabion* (from Italian *gabbione* meaning "big cage"; from Italian *gabbia* and Latin *cavea* meaning "cage") is a cage, cylinder, or box

filled with rocks, concrete, or sometimes sand and soil for use in civil engineering, see e.g. Freeman & Fischenich (2000).



**FIGURE 8.2. GABION RETAINING WALL AT THE NEW AIRDRIE TO BATHGATE PASSENGER RAIL LINK IN THE CENTRAL BELT OF SCOTLAND IS A LANDMARK PROJECT BY NETWORK RAIL TO WIDEN AND RE-OPEN A 24KM LINE CLOSED OVER 50 YEARS AGO. GABION (2015).**

An example of retaining wall made of prefabricated concrete panels to prevent debris from landslides is shown in Figure 8.3, Laboe (2015)



**FIGURE 8.3. EXAMPLE OF RETAINING WALL TO PREVENT DEBRIS FROM LANDSLIDES, LABOE (2015).**

An example of a retaining wall preventing the railway from the sea is give in Figure 8.4.



**FIGURE 8.4. EXAMPLE OF A RETAINING WALL PROTECTING THE RAIL FROM THE SEA IN DEVON, U.K., SEE, SEA WALL RAILWAY (1845)**

## 8.4 REFERENCES

Freeman, Gary E. & Fischenich, J. Craig (2000): Gabions for Streambank Erosion control, EMRRP Technical Notes Collection (ERDC TN-EMRRP-SR-22), U.S. Army Engineer Research and Development Center, Vicksburg, MS, 9 pp. Available at <http://el.erd.c.usace.army.mil/elpubs/pdf/sr22.pdf>

Gabion (2015): <http://www.externalworksindex.co.uk/entry/109844/Maccaferri/Gabion-retaining-walls-Airdrie-to-Bathgate-rail-link/#description-block>

LaBoe, Barbara (2015): What we are doing to prevent landslides near rail lines, Washington State Department of Transportation, January 2015. <http://wsdotblog.blogspot.se/2015/01/what-were-doing-to-prevent-landslides.html>

MAINLINE (2014): *A European Community 7<sup>th</sup> Framework Program research project with the full title: MAINTenance, renewAL and Improvement of rail transport INfrastructure to reduce Economic and environmental impacts*. Research Project 2011-2014 with 19 partners. Grant agreement 285121, SST.2011.5.2-6. Dr. Björn Paulsson, UIC/Trafikverket acted as Project Coordinator. A project summary and 27 deliverables and can be downloaded from [www.mainline-project.eu](http://www.mainline-project.eu)

Terzaghi, Karl (1943), *Theoretical Soil Mechanics*, New York: John Wiley & Sons

Terzaghi, Karl; Peck, Ralph, B. and Mesri, Gholamzeza (1996): *Soil Mechanics in Engineering Practise*, 3<sup>rd</sup> Ed, New York: John Wiley & Sons, 549 pp., ISBN 0-471-08658-4.

Sea Wall Railway (1845): This railway was built by Isambard Kingdom Brunel. The line west from Exeter followed the granting of the South Devon Railway Act on 4 July 1844 and covered the construction of a new railway, a continuation of the Bristol and Exeter Railway, west from Exeter to Plymouth, see <http://www.dawlishwarren.info/useful-info/railway-history/>

## 9. Track and Switches & crossings

---

The text in this chapter mainly mentions track issues. However, largely, approaches, consequences etc are similar for switches & crossings. Particular issues related to crossings are considered explicitly in the chapter.

### 9.1 PRELIMINARIES

#### 9.1.1 SCOPE OF THE CHAPTER

In all operational railways, the track structure, and switches & crossing deteriorate over time. The rate of deterioration depends on the loading (in a very broad sense) of the track. In general, the rate of deterioration accelerates with increase loading. Thus, a major consequence of an upgrade tends to be increased deterioration rates, and a main objective of a structured upgrading process is to ensure that deterioration rates are under control and at acceptable levels. This is only possible to obtain if there are predictive models that can be used to estimate the rate of deterioration due to upgrading.

The important part of assessing the effects of upgrading is considered in the subsequent sections. The proposed methodology is based on assessment using a two-stage approach as outlined in Figure 9.1. The two stages are:

1. Assessment using experience based methods:  
In this stage the effect of the intended upgrading on degradation, safety, costs etc. is assessed with rather simple models based on prior experience. These analyses provide an overview and a first estimation of the consequences (feasibility, costs etc.) of upgrading. From these preliminary evaluation, a decision can be made on whether a refined analyse is motivated in some parts based on uncertainties/risks regarding future degradation and/or safety levels. Experienced based methods can identify cost drivers in an overview manner, but they have limited capabilities in analysing the efficiency of different methods to improve safety, reduce costs etc. This is a consequence of that the methods are based on experience and empirical data and thereby in simplistic terms presume “operations as usual”.
2. Assessment using prediction based methods:  
In this stage, consequences of upgrading are investigated in detail. To this end, numerical simulations (and where appropriate supporting tests) are employed. These investigations are more detailed and thereby require input data on a much more detailed level than the experience based methods. Since the data relates to the characteristics of the operating trains and the track structure, there is a need to define these before the analyses can take place. On the other hand, the prediction based methods are ideal in investigating “what if”-scenarios. This means that the effect of e.g. modifications in track characteristics on future deterioration can be assessed. Consequently, prediction based methods are not the best tool to estimate

overall costs of upgrading, but ideal in investigating the effectiveness of different modifications and in supporting detailed cost analyses of sub-systems that have been identified as major cost drivers.

Experienced based analyses of varying complexity are discussed in Section 9.2. Predictive based analysis are discussed in Section 9.3 in connection to different forms of upgrading. This includes forms of upgrading where the main consequence is not track degradation. (increased loading gauge is in chapter tunnels)

A prediction based assessment can further be employed to analyse the impact of alternative solutions and/or mitigating actions. Such mitigating actions commonly relate to inspection and maintenance practices. Important inspection and maintenance areas that may require additional attention during upgrading are discussed in Section 9.4.

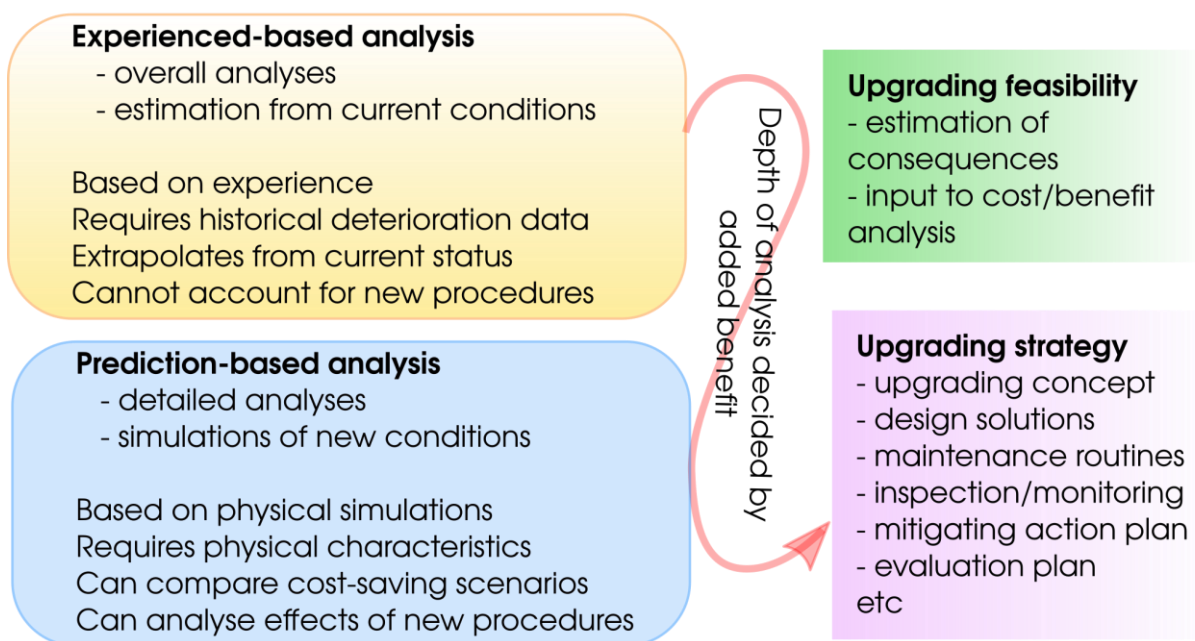

**FIGURE 9.1. FLOW-CHART FOR THE TWO-STAGE APPROACH TO INVESTIGATIONS AND DECISIONS RELATED TO TRACK UPGRADING**

The outcome of the two-stage chain of analyses in Figure 9.1 is a sufficiently detailed cost estimation with uncertainties identified and quantified (with sufficient accuracy). Note that an upgrade analysis does not necessarily imply all steps in Figure 9.1. As an example, a small upgrade, i.e. a slight increase in operating frequency on a line with moderate capacity utilization, would typically only require an empirical based analysis to provide a rough idea on increasing deterioration rates as a basis for future maintenance budgets. Such an outcome represented by the “Upgrading feasibility” box in Figure 9.1. A second case would be e.g. the introduction of a new vehicle type where an empirical based analysis

would provide a first idea on how the new vehicles could deteriorate the track in comparison to existing vehicles, but where a more in-depth prediction based analysis could give a deeper insight. A third scenario could be a switch with a high frequency of faults. Here the overall analysis serves no purpose. Instead, a direct detailed prediction-based analysis should be carried out to provide a good base for an improved design and/or improved maintenance strategies.

Finally, it should be noted that there is no clear-cut distinction between the different types of analyses: The more advanced experience based methods employ numerical simulations (as discussed in section 9.2.2). On the other hand, the prediction based methods typically employ empirical data for calibration and validation purposes. However, there is a major difference in that the experience based models put the emphasis on reflecting empirical trends, whereas the prediction based methods put the emphasis on reflecting the physical reality.

### 9.1.2 A BRIEF OVERVIEW OF TRACK DETERIORATION

A good illustration of how the operational load level influences (mechanical) track degradation is given by the Wöhler curve, depicted in Figure 9.2. Although the slope of the curve varies between different phenomena, the general trend is that the logarithm of the operational life is proportional to the (logarithm of the) applied loading and valid for a broad range of deterioration phenomena. As an illustration, the mechanical fatigue life of a component may decrease by 70% if the load magnitude is increased 10% (indicated by dashed lines in Figure 9.2).

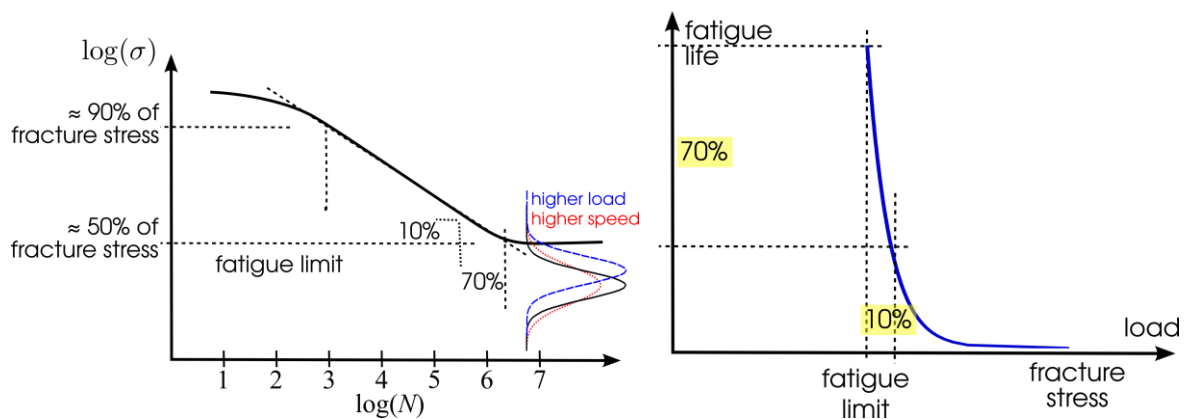

**FIGURE 9.2. THE WÖHLER CURVE IN LOGARITHMIC SCALE (LEFT) WITH AS ROUGH ESTIMATION OF CONSEQUENCES OF HIGHER LOAD / HIGHER SPEED ON THE LOAD SPECTRUM INDICATED. THE RIGHT PICTURE SHOWS THE CORRESPONDING RELATION BETWEEN APPLIED LOAD AND RESULTING FATIGUE LIFE IN A LINEAR SCALE. NOTE THE DRASTIC DECREASE IN FATIGUE LIFE WHEN THE OPERATIONAL LOADING EXCEEDS THE FATIGUE LIMIT.**

Track degradation involves several damage and deterioration phenomena. Some of these and the pertinent main influencing parameters are listed in table 9.1. Note that new damage phenomena may occur as a consequence of upgrading. This can be related to *increased loading* due to the upgrading.



Typical examples are increased rolling contact fatigue due to higher axle loads, and squat formation (tentatively) due to higher traction vehicles, Grassie (2012). Altered damage patterns could also be a consequence of the altered – *although not more severe per se* – operational conditions. Examples are the altered forms of corrugation that may form depending on the operational conditions, Grassie and Kalousek (1993), Grassie (2009). Increased corrugation formation due to higher speeds may then in turn give rise to higher dynamic loads that promote subsurface rolling contact fatigue, Nielsen et al (2005) and Ekberg (2007). Finally, it may be noted that *improved* operational conditions may shift the mode of damage so that a slower deterioration phenomenon will have time to occur before the track is replaced. One example is that decreased wear rates may give time for surface cracks to form on wheels and rails. Note however that a return to higher wear rates is often a sub-optimum solution. The reason is that the increased wear rate is not controlled (as it is in the case of "artificial wear", e.g. by grinding) and may cause a shorter overall operational life of the track.

**TABLE 9.1. SOME TRACK DETERIORATION PHENOMENA**

Deterioration phenomenon	Main influencing loads	Important material/ component features	Time to deterioration
Track settlement	Track forces (vertical and lateral)	Ballast (and sub-ballast) resistance	Medium
Sleeper damage	Vertical (impact) forces, support conditions	Reinforcement, sleeper design, sleeper support	Short if overloaded
Plastic flow	(Effective) stress magnitude	Yield limit, wheel/rail surface profiles	Short
Wear	Contact load (pressure and frictional), sliding distance	Hardness / yield limit	Medium
Plain fatigue	Stress amplitude	Fatigue limit, surface roughness, corrosion	Medium – long
Surface initiated rolling contact fatigue	Frictional contact stresses	Hardness, ductility	Medium – long
Subsurface initiated rolling contact fatigue	Contact pressure	Material defects, fatigue limit	Long

As indicated in Table 9.1, the time for damage to form varies between the different damage phenomena. This can be visualized as Wöhler curves with varying slopes as in Figure 9.3. The dominating damage mode and pertinent life will be a function of the applied loading relating to the different damage modes, and the corresponding slope of the Wöhler curve. Note that in Figure 9.3 the Wöhler curves also have widths that represent the statistical scatter in material resistance for the different phenomena.

As an example, the scenario in Figure 9.3 related to rail damage has thermal load magnitudes that are so low that they will cause very little thermal damage (green). The mechanical loading has such a character that there will be very limited rolling contact fatigue (red), but significant wear (blue). With the definition of “life” in the Wöhler curves of Figure 9.3, it could be expected that the rail life (at the studied section) is on the order of  $10^7$  cycles (or in more understandable terms, some ten million wheel passages) before there is need for mitigating actions (in the case of wear this is usually grinding).

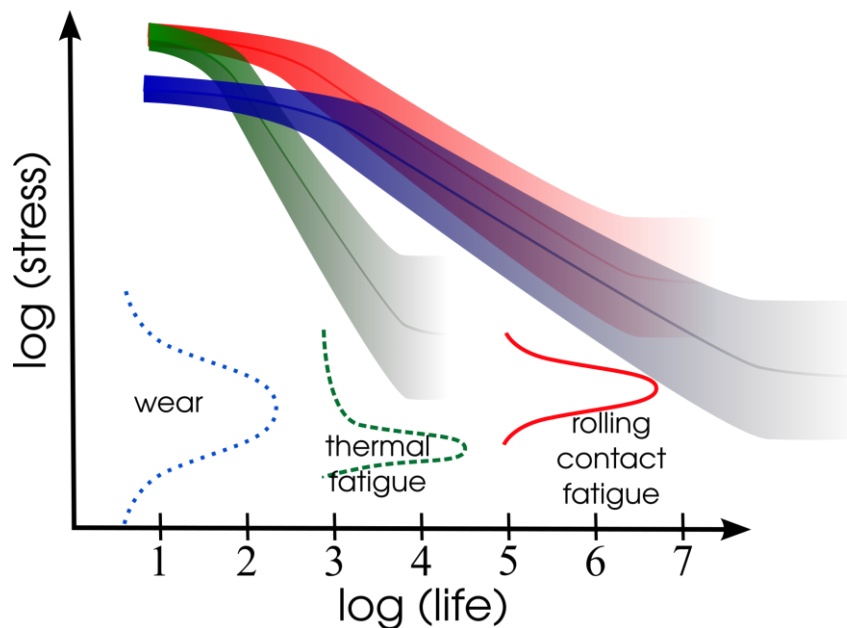

FIGURE 9.3. WÖHLER CURVES AND ASSOCIATED “LOAD” MAGNITUDES RELATED TO WEAR, THERMAL DAMAGE AND ROLLING CONTACT FATIGUE.

### 9.1.3 INFLUENCE OF HIGHER LOADING ON DETERIORATION

“Higher loading” is here used in a very broad sense that includes upgrades featuring increased axle loads, increased speed, but also increased operational frequency. The section gives a very brief overview of potential consequences of upgrading. A more thorough overview of potential consequences of different types of upgrading including predictive and mitigating means is provided in Section 9.3.

Note that deterioration is an intrinsic threshold phenomenon regardless of deterioration mode. This means that below a certain load magnitude the life is very long. This is represented by the horizontal asymptotes in Figure 9.3.

### **INFLUENCE ON TRACK SUPPORT**

---

Ballast subjected to increased loading will (if loading is above the threshold magnitude) experience more deterioration of the ballast stones. This will influence the ballast stiffness and the resistance towards track shift and settlements. The result will be a more severely deteriorated track geometry. Note that wear particles may also decrease the frost resistance of the ballast, see Dahlberg (1997).

In EUROBALT II the main influencing parameters on the ballasted track deterioration was investigated. The main influencing parameter for sleepers is often not the average load, but extreme impact load magnitudes that can be expected under different operational conditions. To complicate matters, the resistance of a sleeper against impact loads will depend greatly on the support conditions. Further, a sleeper designed to sustain the most extreme impact loads will be highly non-optimal since it will increase loading of other parts of the system. Consequently, design of sleepers should be based on a probabilistic approach where the risk of high impact loads and subsequent sleeper failures is analysed. Further, a well-tamped and compacted track will significantly decrease the risk of a sleeper fracture, see e.g. Bolmsvik and Nielsen (2006).

Fastenings are subjected to fatigue due to rail and sleeper vibrations that can be caused e.g. by rail corrugation, joints etc. Detachment of fastenings due to fatigue failure or other causes will generally worsen the situation since vibrations will increase. This is a typical example of a negative "deterioration spiral" that is common in track deterioration: Deterioration increases the loading that increases the rate of deterioration that increase the loading further, etc.

### **INFLUENCE ON RAILS**

---

The "fastest" damage phenomenon for a rail is plastic deformation that occurs if contact stress magnitudes are too high and (usually) the contact occurs close to the side of the rail. In extreme cases, plastic deformation decreases with the number of load cycles due to the formation of residual stresses and also "run-in" where the wheel and rail contact profiles adopt to each other (to some extent) through plastic deformations.

When plastic deformation decreases, wear may take over as the dominating form of deterioration, Johansson et al (2011). Wear can be a fairly fast process that may be self-stabilizing in the sense that stress magnitudes are decreased as the rail is worn-in towards (an envelope of passing) wheel profiles. However, wear may also increase the propensity for additional damage (e.g. rolling contact fatigue) due to degrading surface conditions. One example of this is the adverse effect of hollow wear, Fröhling et al (2008) and Karttunen et al (2014). Another example is the influence of periodic wear that may result in the formation of (different forms of) corrugation and wheel out-of-roundness. Periodic wear will here increase dynamic loads that may cause additional deterioration.

If operational loads are high, and wear rates are kept at reasonable levels, surface initiated rolling contact fatigue will often be the next problem to occur, Tournay and Mulder (1996). Although there

are many different types (and also classifications) of surface initiated rolling contact fatigue, the most common tend to be headchecks that occur at the gauge corner in medium to shallow curves, UIC (2002), and squats/studs, Grassie et al (2012), that occur more stochastic on the rail head.

Subsurface initiated rolling contact fatigue, Ekberg and Kabo (2005), may occur because of high dynamic contact pressures and material defects both in wheels and in rails; in the latter case often in welds. This is a relatively slow growing type of fatigue (at least if material defects and tensile residual stresses are moderate) that may cause severe damage.

Plain fatigue may occur in the foot and web of a rail. In particular, this may be the case in connection to bolt holes e.g. for fishplates at insulated joints. The result may be a complete rail break. In the case of a foot crack, the critical flaw size that may initiate a rail break is small (in the order of centimetres) Ekberg et al (2015). In the case of a crack setting out from a hole, the crack may break off a considerable length of the railhead. It may also detach fishplates, which may have very adverse effects, as manifested e.g. by the accident at Brétigny-sur-Orge outside Paris in 2013. It should here be noted that holes at insulated joints are especially affected since the joint typically introduces an impact load and also provides a free surface that aids plastic deformation and formation and growth of fatigue cracks, Sandström and Ekberg (2009).

Finally, it should be noted that all phenomena mentioned above might occur also in switches & crossings. Here the situation is aggravated by the geometry of a switch that introduces geometrical irregularities etc. These irregularities will increase the dynamic loads. Further, the switch and crossing geometries introduce free edges close to the wheel–rail contact loads. This will promote both plastic deformations and the propensity for fatigue cracking. How large these effects are, can be appreciated by a comparison between forces induced during switch negotiation, and forces induced during the negotiation of a sharp curve with the same radius as the switch, see Braghin et al (2013).

#### **INFLUENCE ON VEHICLES**

---

Upgraded conditions will influence also the vehicles. If the upgrading includes renovation or replacement of track and vehicles, this may be beneficial: A new track has less track faults that cause high loads; new vehicles perform better etc. This may initially be manifested as a decreased deterioration. However, if the overall load magnitudes (in a general sense) are increased, deterioration will eventually increase. Depending on the type of upgrading this may be manifested in different ways.

Increased speed and increased axle loads will increase vertical loading (in the case of higher speed due to the increased dynamic loads related to the passage of track irregularities), and often result in increased brake and traction demands. The result will generally be higher risks of rolling contact fatigue and track settlements, which need to be counteracted by more strict maintenance demands.

Another scenario is an increased capacity outtake that may (depending on the operational scenario) cause the vehicles to be more heavily utilised. This will increase the deterioration per time unit and leaves less time for maintenance.

Note that this brief summary focuses on degradation related to wheel/rail interaction. The rate of degradation is also often dependent on the climate (e.g. winter and dry spring conditions). In addition, an upgrading typically also prescribes general demands on vehicles regarding stability, structural integrity, engines, aerodynamics etc.

#### INFLUENCE ON NOISE, VIBRATION AND OTHER ENVIRONMENTAL FACTORS

There are cases when noise emissions may be critical for an upgrading – in other words; if noise emissions cannot be managed, the upgrading will not be allowed. Dealing with this is complicated by the fact that the influence of upgraded operations on noise emissions is very dependent on the operational conditions.

Noise emissions may be estimated by numerical simulations, and measured and controlled. There are however complications in that some forms of emissions (e.g. squeal) are notoriously difficult to predict. Further to obtain comparable demands on measurements, the measurement sites need to be harmonized, see e.g. UIC (2014). In addition, vibrations may add to the problem.

For mitigating actions against noise pollution and vibrations, see e.g. the outcome of the EU-funded projects SilentTrack, SilentFreight, QCITY and RIVAS. It may be noted that simple solutions to noise reductions have already often been implemented on sensitive sites. This calls for tailored solutions to target critical components (track sections and/or vehicles) if conditions are to be further upgraded.

To see the effects of vibration Ingemansson (2001) carried out a study of the Stora-Enso train see figure 6.3.2. The Stora-Enso train consists of several wagons of the same sort and with similar loading. The measurements was carried out in Partille east of Gothenburg. Different frequencies where analysed in order to evaluate which houses that was most sensitive to vibrations and if the Stora-Enso train caused more and severe vibration problems.

Additional environmental factors that may require investigations include particle emissions (e.g. due to mechanical braking or tunnel operations), and transportation of hazardous goods.

#### INFLUENCE ON SAFETY

To maintain safety levels in an upgraded condition is usually a strict requirement. Often this is not a major problem: If upgrading is carried out in a structured manner with suitable analyses and implementation of counter-measures, safety may actually increase. However, safety assessments are often required to be assessed using strict (and often national) protocols.

General statements about these protocols are difficult to make. However, the D-rail project, D-RAIL (2015), provides an overall assessment of freight operations and tools for risk, LCC and RAMS assessment of safety promoting actions. As mentioned above, safety levels generally increase when the track is upgraded, but it may be cumbersome to obtain a formal validation/approval of this. To appreciate why, recall that safety levels are very high in most European countries. Consequently, it is very difficult (not to say impossible in most cases) to obtain a statistical proof of unaltered or improved safety levels. On the other hand, the risk is never zero, and accidents do occur. So, if a personal responsibility is attached to the statement that safety levels are unaltered or improved, the lack of statistical "hard evidence" and the potential risk of personal repercussions leads to a very low incitement to make such a statement.

#### 9.1.4 EVALUATING OF THE EFFECTS OF UPGRADING

Depending on the nature of the upgrade, different consequences may be expected. When evaluating such consequences of upgrading, three important facts should be remembered:

- A new piece of infrastructure is always "better" (in terms of fewer failures) during the first years of operations. This is a consequence of the lack of large material defects in the new hardware. Thus, to get a fair evaluation of the effectiveness of the upgraded infrastructure, such an evaluation should be carried out after the "run-in" period.
- Further, it takes time for altered operational conditions to give an effect on quality indicators. In particular, it often takes a long time before changes are sufficiently statistically significant that they can be distinguished from random scatter and/or seasonal changes. Consequently, evaluations must be carried out over a fairly long period of time.
- The railway is a tightly integrated system. For example, heavier trains will increase wheel and rail deterioration, but also increase track settlements. If these settlements cause higher dynamic loads, settlements will be further magnified. The result may be damage e.g. to abutments and other stiff sections. Consequently, not only the part of the track directly affected by upgrading, but also components indirectly affected need to be assessed and monitored.

#### 9.1.5 MITIGATING ACTIONS

There are a multitude of actions available to mitigate unwanted consequences of upgrading. In fact, if the upgrading is handled properly, deterioration may actually decrease in the upgraded state. As an example, we can look at upgrading by increased axle loads. Here the frictional stresses will generally increase, which will increase the risk of surface initiated rolling contact fatigue. However, better steering vehicles, better control of braking and traction and optimised grinding and lubrication practices may reduce this effect. Further, a better match of wheel and rail profiles will better distribute

the remaining frictional forces. In this way, the result may actually be a reduced deterioration even if the operational performance has increased.

In order to prevent detrimental consequences to an as large extent as possible, and also to be able to plan mitigating actions towards remaining issues, a thorough understanding in particular of deterioration mechanisms is required. To this end, some common upgrading scenarios are listed below together with likely consequences regarding the mechanical loading and subsequent deterioration. Note that this is just a first introduction. A more in-depth discussion is provided in sections 9.3 and 9.4.

**Upgrading through new vehicles** often results in better running performance due to the improved characteristics of the new vehicles. This generally reduces deterioration (or can allow for higher loading while keeping degradation levels constant). Note however that the new vehicles require (potentially new) maintenance procedures to maintain the high quality.

**An increased axle load** will increase the (average) contact load. This will result in increased propensity for wear, rolling contact fatigue, component fatigue, track settlements etc. In addition, a higher axle load may require higher levels of traction and braking efforts that will add to the problem. The problem can be mitigated by a better design of the load supporting structure, e.g. improved wheel/rail profiles, heavier rail of premium grade, high performance sleepers and reinforced structures and substructure.

**An increase in speed** will lead to a larger scatter in contact load magnitudes, which may cause more damage (and in some cases a different type of damage) on wheels and rails. Operations at higher speeds will also be more sensitive to (track geometry, rail/wheel profile and material) defects. This usually requires stricter maintenance requirements. Note also that operations at higher speeds commonly result also in higher magnitudes of traction and braking. These will result in a higher propensity mainly for crack formation and wear.

**An increased capacity outtake** with existing train fleet will result in an increased loading per time unit even though the loading of the individual vehicles does not increase. This will result in a faster degradation. At the same time, there is often less time for maintenance and repair. Further, faults will become costlier since they will have a higher influence on operations (a given disruption will influence more goods). The same effects are also partly valid in cases of upgrading with **longer trains**. In this case there may be additional complications by longitudinal vibrations of trains, need for longer meeting tracks, requirements for larger tractive/braking efforts by the locos etc.

**Upgraded maintenance procedures** will, if properly employed, decrease operational loads etc. This will lead to a longer operational life of the infrastructure and also less traffic disruptions due to malfunctioning trains or infrastructure. Note that this is the reason why increased operational frequencies often require an upgrade towards planned (preventive) maintenance since there is typically less time in track to carry out maintenance, and in particular unplanned maintenance. In such

a scenario, the upgraded maintenance practices may allow to keep the current status of track and vehicles with less maintenance time available.

**Upgrading through improvement of the track structure** will in general decrease loads (in a broad sense e.g. due to decreased "dynamic effects") and also increases the operational life of the track. The latter is both a consequence of the decreased operational loading and of the longer residual life of the new track structure. Such an upgrade is typically required if higher axle loads and/or speeds are employed.

### 9.1.6 REFERENCES

Bolmsvik, R. and J.C.O. Nielsen, 2006. Dimensionerande böjmoment i sliprar vid 35 tons axellast (Dimensioning bending moments in sleepers for axle load 35 tonnes; in Swedish), Research Report 2006:9, Chalmers Applied Mechanics, Gothenburg, 44 pp

Braghin, F., A. Ekberg, B. Pålsson, D. Sala, D. Nicklisch, E. Kabo, P. Allen, P. Shackleton, T. Vernersson and M. Pineau. 2013. D-RAIL Deliverable D3.2 – Analysis and mitigation of derailment, assessment and commercial impact, 283 pp + annex 18 pp.

Dahlberg, T, 1997. Bibliography for EUROBALT II project on railroad ballast used as track substructure, Linköping University, IKP, Linköping (Sweden): Part 1 - Literature review of research on railroad ballast used in track substructure (48 references), 19 pp, Part 2 - Bibliography for EUROBALT II project on railroad ballast used as track substructure, 91 pp, and Part 3 - Thesaurus to the Bibliography, 11 pp

D-RAIL. May 2015. <http://d-rail-project.eu>

Ekberg, A. and E. Kabo. 2005. Fatigue of railway wheels and rails under rolling contact and thermal loading—an overview. *Wear* 258, (7): 1288-1300

Ekberg, A., E. Kabo, and J.C.O. Nielsen. 2015. Allowable wheel loads, crack sizes and inspection intervals to prevent rail breaks. to be presented at the International Heavy Haul Conference IHHA2015, 9 pp.

Ekberg, A., E. Kabo, JCO Nielsen, and R. Lunden. 2007. Subsurface initiated rolling contact fatigue of railway wheels as generated by rail corrugation. *International Journal of Solids and Structures* 44, (24): 7975-7987

EUROBALT II Main influencing parameters on the ballasted track deterioration. Synthesis report on parameters selection for WP1.

Fröhling, R., A. Ekberg, E. Kabo, 2008. The detrimental effects of hollow wear—field experiences and numerical simulations. *Wear* 265, (9): 1283-1291

Grassie, S. L. 2009. Rail corrugation: Characteristics, causes, and treatments. *Proceedings of the Institution of Mechanical Engineers, Part F: Journal of Rail and Rapid Transit* 223, (6): 581-596



Grassie, S. L. 2012. Squats and squat-type defects in rails: The understanding to date. Proceedings of the Institution of Mechanical Engineers, Part F: Journal of Rail and Rapid Transit 226, (3): 235-242

Grassie, S. L., and D. I. Fletcher, E. A. Gallardo Hernandez, and P. Summers. 2012. Studs: A squat-type defect in rails. Proceedings of the Institution of Mechanical Engineers, Part F: Journal of Rail and Rapid Transit 226, (3): 243-256

Grassie, S. L., and J. Kalousek. 1993. Rail corrugation: Characteristics, causes and treatments. ARCHIVE: Proceedings of the Institution of Mechanical Engineers, Part F: Journal of Rail and Rapid Transit 1989-1996 (vols 203-210) 207, (16): 57-68

Ingemansson Technology AB, En studie av vibrationer och buller före och efter införandet av Stora Enso-boxen (STAX25), godstrafik med högre axellast. Rapport H-17306-r-B. Göteborg 2001-04-20

Johansson, A., B. Pålsson, M. Ekh, J.C.O. Nielsen, M. Ander, J. Brouzoulis and E. Kassa. 2011. Simulation of wheel-rail contact and damage in switches & crossings, Wear, vol 271, nos 1-2, pp 472-481

Karttunen, K., E. Kabo, A. Ekberg, 2014. Numerical assessment of the influence of worn wheel tread geometry on rail and wheel deterioration. Wear 317, (1-2): 77-91

Nielsen, J.C.O, A. Ekberg, and R. Lunden. 2005. Influence of short-pitch wheel/rail corrugation on rolling contact fatigue of railway wheels. Proceedings of the Institution of Mechanical Engineers, Part F: Journal of Rail and Rapid Transit 219, (3): 177-187

Sandström, J., and A. Ekberg. 2009. Numerical study of the mechanical deterioration of insulated rail joints. Proceedings of the Institution of Mechanical Engineers 223, (F2): 265

Tournay, H. M., and J. M. Mulder. 1996. The transition from the wear to the stress regime. Wear 191, (1): 107-112

UIC. 2002, Rail defects. Leaflet 712R, 4th edition: 107 pp

UIC. 2014. HRMS: Harmonization – Running behaviour and noise on measurement sites, 153 pp.

## 9.2 EXPERIENCE BASED METHODS

In this section, we consider methods to predict consequences of operational upgrades that are based on earned experiences. Intrinsically these methods are based on historical experiences. If these experiences are for the line to be upgraded, they therefore do not explicitly account for the upgraded conditions. If the experience instead is gained from other lines with operating conditions similar to the upgraded conditions, they typically do not account for all features (e.g. climate conditions, vehicles) of the line to be upgraded.

The presented methods are mainly useful in providing budget estimates and a first analysis of likely consequences related to upgraded operational conditions. Depending on the outcome, the analysis can then be refined if it is clear that such refined analyses are needed to provide an additional benefit

that exceeds the costs of these refined analyses. Methods for refined analyses are presented in section 9.3.

Finally, it can be noted that the methods focus on deterioration of the track structure. Models more suitable of studying consequences on vehicles are presented in section 9.3.

### 9.2.1 OVERALL ESTIMATION MODELS

The simplest estimation of the increased degradation due to upgrading is to presume that deterioration rates are proportional to the load (typically measured in MGT). This results in a linear relationship between load and track quality degradation on the form

$$DQ = k_1 \cdot P \quad (1)$$

Here  $DQ$  is the degradation in track quality (in general terms) due to the loading  $P$  (e.g. measured in MGT over time that  $DQ$  is evaluated) and  $k_1$  is a coefficient that would depend on the basic conditions of the track, the state of the operating vehicles etc. An increase in loading with  $\Delta P$  would then give a decrease in track quality that can be expressed as

$$\frac{DQ + \Delta DQ}{DQ} = \frac{k_1 \cdot (P + \Delta P)}{k_1 \cdot P} \Leftrightarrow \frac{\Delta DQ}{DQ} = \frac{\Delta P}{P} \quad (2)$$

In other words, the relative increase in degradation is *under these presumptions* equal to the relative increase in loading. To be useful in investment decision, the increased degradation then needs to be related to an increased life cycle cost. In its simplest form, this can also be presumed as a linear function.

As understood from the Wöhler curve in Figure 9.2, a linear approximation should only be reasonable if the increase in load magnitudes is low. A more refined approach is to account for the fact that damage typically increases exponentially with the increased loading. The overall track quality can then be expressed on the form, Veit and Marschnig (2011)

$$Q(t) = Q_0 e^{bt} \quad (3)$$

where  $Q_0$  is the initial track quality (in Veit and Marschnig (2011) defined by a so-called MDZ index),  $b$  is the deterioration rate and  $t$  the elapsed time.

### PRACTICAL IMPLICATIONS

For both of the simplified models described above, the effects of all influencing parameters need to be combined into two single measures – track quality and load – that reflect the expected consequences of the upgrading. However, in reality different parameters will influence different forms

of degradation in different manners. This limitation can to some extent be overcome by adding more variables as shown in the example below.

The limited number of variables in these models is their most appealing feature: It provides a very clear link between input data and resulting increase in degradation, and it also implies that there is a limited need to identify input. However, this is to some extent a chimera: Since the few input data required should reflect *all* the degradation properties and *all* acting loads they are not readily identifiable. Instead they are usually estimated by regression analysis featuring historical data on load magnitudes and degradation rates (where both “load” and “deterioration” will need to be defined based on available measurement data). Further, due to the exponential nature of equation (3), the prediction (especially long-term predictions) will be very dependent on the chosen deterioration rate *b*.

The usefulness of these models also depends on the upgrading scenario. For upgrades through increases in (axle) load, an exponential relationship as above can be adopted. Note however that different track components will respond differently to the increased load. As an example, for rails increased wear and/or rolling contact fatigue may result. Which of these two damage phenomena that will dominate will depend on the operational conditions. It may even be that an increased loading will shift the dominating mode of damage from one form to the other. Especially in the case that the upgrading includes updated running gear this may be the case. The practical consequence is that not only may deterioration *rates* change due to the upgrading; the (dominating) *form* of deterioration may also shift. Such outcomes cannot be predicted by the overall models.

Upgrading through increased speed is more cumbersome since the nominal (static) load does not change. The peak loading will however increase due to dynamic effects<sup>1</sup>. This increase may be estimated by more or less sophisticated means ranging from dynamic load factors, see e.g. Esveld (2015) to multibody dynamics simulations (which will be discussed at length in section 9.3). However, since the overall models require a single load magnitude, there will still be a need to translate the broader load spectrum to an “equivalent load magnitude”.

It should also be noted here that higher speeds increase the need to limit track geometry irregularities etc. Consequently, increases in speed will typically not only increase deterioration rates, but also increase demands on track quality with related needs for improved maintenance.

#### AN EXAMPLE FROM 25 AND 30 TONNES INVESTIGATIONS IN SWEDEN

In connection to upgrading of maximum axle load from 25 tonnes to 30 tonnes on the Iron Ore line in northern Sweden, and from 22.5 to 25 tonnes on main freight lines in Sweden investigations were made on the consequences on increased deterioration, see e.g. Banverket (1996), Banverket 1996b and Banverket (2001). In short, the increase in maintenance costs was in Banverket (2001) estimated

---

<sup>1</sup> In essence, the increased speed will lead to a broadening of the load spectrum so that while the average load remains constant, the magnitude of the maximum load will increase and the magnitude of the minimum load will decrease, see figure 9.2

to some 1.4–4.8 %, on the Ore line. The increase will depend on line properties (curve radius etc.), freight / passenger traffic ratio, normal / high speed, as well as the current maintenance costs. The model employed to estimate the costs includes track – mainly rail – deterioration described by two mechanisms:

- Fatigue (both at the wheel–rail contact, and due to internal defects e.g. due to welding)
- Wear with influence of rail lubrication, rail curve radius as well as car type considered

The relative track deterioration was estimated by a formula of the type:

$$E = k \cdot T^\alpha \cdot P^\beta \quad (4)$$

where  $k$  is a constant specific for each section of the railway line,  $T$  is total accumulated tonnage (since track construction), and  $P$  is the axle load. The value of exponents  $\alpha$  and  $\beta$  depends on the type of deterioration considered. The employed model can also consider that operational data vary in time.

### 9.2.2 COMPONENT DETERIORATION MODELS

The consideration of several deterioration mechanisms that was employed in the example above can be taken further by considering deterioration of different parts of the track structure and/or by considering different types of loading / different forms of deterioration. These methods can generally be considered as combinations of individual Wöhler curves (cf Figure 9.3 and the example above). As compared to the overall deterioration models, these models employ more vehicle and track data. This demands more knowledge on the upgraded system, but in return the analysis provides a more detailed prediction of the outcome of the upgrading. Note that even though the component deterioration model can predict how the upgrading affects deterioration of different components, the ability to investigate the effectiveness of mitigating actions and to predict detailed deterioration patterns are generally limited. Models more capable of such analyses are presented in section 9.3.

In the literature, there are over 20 track deterioration models Öberg and Andersson (2009) of which some fall under the category of “component deterioration models”. The current presentation focuses on two of these: A model described in Öberg and Andersson (2009) which was developed in 2006–2008 for the needs of Banverket (now Trafikverket), and a second model described in Worley and Burstow (2014) that was developed for the introduction of Variable Usage Charge (VUC) rates by Network Rail in Great Britain.

#### EXAMPLE 1 – TRACK DETERIORATION MODEL FOR SWEDISH RAILWAYS

---

This track deterioration model presented in Öberg and Andersson (2009) considers four deterioration mechanisms:

- a) track settlements (due to non-uniform movements in the ballast),

- b) component fatigue (including switches & crossings, internal fatigue of rails, fastenings, ballast, rail pads, etc.),
- c) abrasive wear
- d) (surface initiated) rolling contact fatigue of rails.

The model was developed as a basis for a track access charging system for Banverket. It is able to include vehicle characteristics and relate these to track deterioration. This track deterioration model is implemented in a software package called DeCAyS (**D**eterioration **C**ost **A**ssociated with the **R**ailway **S**uperstructure), which is designed in an Excel environment.

#### MODEL FRAMEWORK

Axle load, un-sprung mass and wheelset steering capability are decisive for track deterioration and considered in the model. The model uses the dynamic vertical wheel load instead of the axle load. This makes it possible to account for the quasi-static force contributions due to curving. The influence of speed and un-sprung mass on the high-frequency part (up to some 100 Hz) of the dynamic vertical wheel load is also considered.

In this model, settlement (a) and component fatigue (b) are taken as proportional to the cube of the wheel load. The deterioration therefore increases progressively with increased axle load.

The wear analysis (c) in the model is captured using the wear number concept, which is often referred to as  $T\gamma$  (i.e. product of total creep force and total creepage) and is a measure of the frictional energy dissipation in the wheel-rail contact. Note that energy dissipation due to rotation (spin) is not included in  $T\gamma$ .

Rolling contact fatigue (RCF) (d) and wear (c) are considered as competitive mechanisms: For small curve radii where wear is the dominating mechanism, small initiated RCF cracks are worn off. Thus, the total deterioration from wear and RCF in Öberg and Andersson (2009) is divided in two regimes: one where the RCF is dominating and another where wear is dominating. Following Burstow (2004) when the wear number ( $T\gamma$ ) is between 0 and 15 N, it is considered that no RCF or wear will occur. For  $15 \text{ N} < T\gamma < 65 \text{ N}$  RCF is predicted to occur and should be ground off by maintenance actions. In the range of  $65 \text{ N} < T\gamma < 175 \text{ N}$  RCF cracks will be partly removed by wear. If the wear number exceeds 175 N wear will be dominating. This is presented graphically in Figure 9.4.

The total track deterioration depends not only on vehicle characteristics, but also on tonnage and on curve radii since track forces and frictional energy dissipation depend on the curve radius. The deterioration should therefore be evaluated for different curve radii zones.

The analyses of the total accumulated annual deterioration cost  $\Delta E_a$  for the whole railway network with  $Z$  vehicles and accounting for  $j$  curve zones, is based on the formula proposed in Öberg and Andersson (2009):

$$\Delta E_a \approx \sum_z \left[ k_1 \cdot \sum_j T_z \cdot \frac{L_{Rj}}{L_t} \cdot Q_{totj}^3 + k_2 \cdot \sum_j T_z \cdot \frac{L_{Rj}}{L_t} \left[ \sqrt{Q_{tot}^2 + Y_{qst}^2} \right]_j^3 + k_{34} \cdot \sum_j T_z \cdot \frac{L_{Rj}}{L_t} \cdot \frac{\sum_{i=1}^{n_z} [f(\bar{F}_v \bar{v})_i]}{m_z} \right] \quad (5)$$

The formula consists of 3 terms. Each term including a marginal average cost coefficients

- $k_1$  (for settlement)
- $k_2$  (for component fatigue)
- $k_{34}$  (wear and RCF of rails)
- $T_z$  is tonnage or traffic volume for vehicle type Z over the studied period in gross tonne-km
- $L_{Rj}$  is the length of the curve zone with an average radius of  $R_j$  [m]
- $L_t$  is the total length of the track section or the network [m]
- $Q_{tot}$  is total vertical wheel load (usually low pass filtered at 90 Hz [kN])
- $Y_{qst}$  is quasi-static lateral wheel load or “guiding force” [kN]
- $f(\bar{F}_v \bar{v})$  is a function relating wear and RCF to the friction energy dissipation for the outer wheels, see Figure 9.4
- $\bar{F}_v$  is total creep (friction) force [N]
- $\bar{v}$  is total creepage [–]
- $m_z$  is mass of vehicle type Z in tonnes (the total weight of each freight wagon and an additional 50 per cent to account for passengers is employed for passenger wagons)
- subscript  $i$  relates to axle  $i$ .

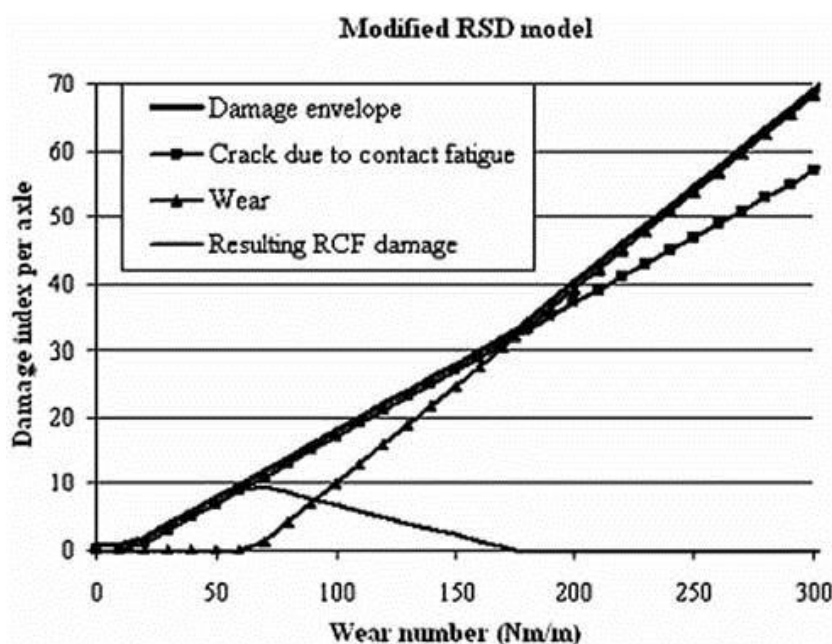

FIGURE 9.4. DAMAGE FUNCTION TO QUANTIFY WEAR AND RCF OF RAILS AS ADOPTED IN ÖBERG AND ANDERSSON (2009) FOLLOWING BURSTOW (2004).

Some important conclusions are drawn from simulation results based on railway traffic in Sweden Öberg and Andersson (2009): Wheelset steering capability is crucial for track deterioration and will significantly influence predicted wear and RCF. The un-sprung mass and the height of the centre of gravity also have some influence on track deterioration. The type of track deterioration predicted by the model is also strongly dependent on the vehicle type. Heavy freight wagons with link suspensions are predicted to cause mainly settlement and component fatigue. Y25 bogies are predicted to produce (among other things) wear and RCF deterioration. The latter is also verified in more detailed analysis in Karttunen et al (2014) where track irregularities are accounted for. Freight wagons with three-piece bogies of standard type are predicted to produce the highest deterioration of all freight wagons.

#### CALIBRATION OF THE MODEL

The model was applied to Swedish mainline traffic, but is according to Öberg and Andersson (2009) believed to predict realistic results also for heavy-haul rail operations. The deterioration model was calibrated against total annual marginal cost for the Banverket's track maintenance together with known and estimated traffic data per vehicle type for the Swedish rail network in 2001. The values of an average marginal cost (excluding reinvestments) as 0.0003 Euro/gross ton-km, and the total annual traffic volume of 64 000 Mega gross ton-km were used in the analyses. Track settlements are assumed to be responsible for 25 % of total marginal cost, component fatigue for 35 % and wear and RCF for the remaining 40 %.

#### EXAMPLE 2 – VARIABLE USAGE CHARGE MODEL FOR NETWORK RAIL

The variable track usage charge model from Worley and Burstow (2014a) and Worley and Burstow (2014b) is used to determine track access charges to be paid by train operators to Network Rail for infrastructure use. The purpose of the charge is to recover Network Rail's operating, maintenance and renewal costs that vary with traffic, so called "wear and tear" costs. The charge is designed to be cost reflective, e.g. "track friendly" vehicles, which cause less "wear and tear" to the network, are subject to lower variable usage charge (VUC) rates than vehicles, which are more damaging.

#### METHODOLOGY

The VUC recovers following costs depending on traffic Worley and Burstow (2014b):

- track costs (85%), including maintenance and renewal costs, 70% of costs relate to vertical rail forces and 30% of costs relate to horizontal rail forces;
- signalling (5%) including maintenance costs and points renewal costs;
- civil structures (10%) including costs associated with bridges, embankments and culverts.

The Network-wide VUC costs defined as the product of "efficient average VUC rate" and the "Network-wide traffic" give an assessment of a vehicle's "track friendliness". There are four key vehicle parameters that are used to determine the "track friendliness score" Worley and Burstow (2014b):

- 
- operating speed,
  - axle load,
  - un-sprung mass,
  - bogie primary yaw stiffness (indicative of curving capability).

The higher the values of these parameters, the worse the vehicle's "track friendliness score" and the higher the vehicle's VUC rate. These rates are translated into variable usage costs using a cost allocation model. Track damage costs are estimated by surface damage components:

- horizontal track damage,
- vertical track damage,
- RCF / Wear (referred to as T-gamma).

T-gamma (see also above) depends on vehicle suspension type, curve radius and cant deficiency and can be evaluated by vehicle dynamics simulations.

#### REQUIRED INPUT DATA AND PRECISION

---

In order to calculate VUC rates for different vehicle types a special VUC calculator was developed Worley and Burstow (2014a). The calculator (in the form of a spreadsheet) is a tool that calculates a VUC rate based on relevant information on vehicle characteristics.

- **Vehicle type** (passenger or freight).
- **Motor / trailer**. This does not impact the level of VUC rate but clarifies whether the proposed rate will apply to the motor or trailer cars.
- **Locomotive, coach or multiple units**. All other things being equal, coaches and multiple units pay lower VUC rates than locomotives. This reflects the lower traction forces that each wheel imposes on the track.
- **Number of axels** used (together with vehicle weight) to calculate the average axle load of the vehicle.
- **Vehicle weight in tonnes**. Tare weight of the vehicle in serviceable condition (i.e. weight of the vehicle with no passengers).
- **Total number of (passenger) seats**. For multiple units and coaches the VUC is calculated for the weight of the vehicle with 50% of seats presumed full, and assuming 75 kg per passenger.
- **Un-sprung mass** (kg per axel). This comprises the masses of the wheelset, axle boxes, brake gear, axle-mounted gearbox or final drive, and any other equipment that is mounted on the wheelset or axle boxes. An average value should be taken if the un-sprung mass is not the same for every axle.
- **Maximum speed** (in miles per hour).



- **User calculated operating speed.** The operating speed can be estimated from timetable excluding stopping time at stations. If the “user calculated” speed is omitted, the operating speed will be estimated by the standard formula: Operating speed = 0.021 \* (max speed)<sup>1.71</sup>
- **Curving class.** The specified “curving class” is a way of categorising vehicles according to the rail surface damage in terms of wear and rolling contact fatigue that they generate.
- **User defined T-gamma table.** T-gamma values could be determined from vehicle dynamics simulations for the vehicle over a specified range of curves. In this case it is not necessary to select one of the generic curving classes.

The output from the VUC calculator sets out the vehicle characteristics and the calculated VUC rate, broken down by asset type.

To calculate a freight VUC rate requires additional information on vehicle characteristics such as:

- **Suspension band.** Wagons with “track friendly” suspensions/bogies will pay a lower VUC than wagons with suspensions/bogies that impose higher forces on the track.
- **Ride Force Count (RFC) value.** The RFC is estimated to provide a quantitative assessment of the “track friendliness” of a wagon’s suspension/bogie type, following vehicle dynamics simulation.
- **Freight commodity.** There is an option to select all commodities or several commodities from a list. The VUC rate will be calculated for each commodity.

#### THE USE OF “TRACK FRIENDLINESS” FORMULAE AND LIMITATIONS

VUC rates are designed to be cost reflective. For each vehicle type a “track friendliness score” can be calculated and used to apportion scores. To assess “track friendliness” one of the following empirical formulae for track friendliness scores, Worley and Burstow (2014b) may be used depending on the VUC cost category:

$$C_t \cdot (0.473 e^{0.133A} + 0.015 S \cdot U - 0.009 S - 0.284 U - 0.442) \cdot GTM \cdot axels$$

‘track friendliness’ score – vertical track loads

$$C_t \cdot A^{3.00} \cdot S^{1.52} (\text{per tonne} \cdot \text{mile}) \cdot GTM$$

‘track friendliness’ score –civil structures

Where

$$C_t = \begin{cases} 0.89 & \text{for loco – hauled passenger stock and multiple units} \\ 1.0 & \text{for all others} \end{cases} \quad \text{for vertical track}$$

$$C_t = \begin{cases} 1.2 & \text{for 2- axle freight wagons} \\ 1.0 & \text{for all others} \end{cases} \quad \text{for civil structures}$$

A – axle load (tonnes) within the range of 5 to 25 tonnes,

*S* – operating speed (miles/hour) within the range of 25 to 100 mph,

*U* – un-sprung mass (tonnes/axle) within the range of 1 to 3 tonnes,

*GTM* – gross tonne miles.

Track friendliness scores for horizontal track loads. It is allocated using the “curving class” methodology, i.e. with user input of T-gamma with curvature for required vehicle(s) and conversion of T-gamma to wear and RCF damage for each radius, weighting of damage by population of curve radii in network and finally converting damage to cost for each curve and summation to get total cost Worley and Burstow (2014b).

### 9.2.3 REFERENCES

Banverket, 30 ton på Malmbanan, Rapport 4.4: Underhåll – Spårmekanisk analys (in Swedish), 31 pp, 1996

Banverket, 30 ton på Malmbanan, Rapport 5.1: Zeta-Tech – Quantification of track maintenance costs, 44 pp, 1996b

Banverket, 25 på sträckan Borlänge/Göteborg, Rapport 5.4: STAX 25 ton – Spårteknik, Nedbrytningsmodell för spåröverbyggnad (in Swedish), 20 pp, 2001

Coenraad Esveld, Modern Railway Track, MRT-Productions, 745 pp, 2015, ISBN 9781326051723

Veit, P, and S Marschnig. Towards a more sustainable track. Railway Gazette International 167, no. 1 (January 2011): 42-44.

J Öberg and E Andersson. Determining the deterioration cost for railway tracks, Proc IMechE, 2009, vol 223, Part F: J Rail Rapid Transit, p 121-129.

M C Burstow. Whole life rail model application and development for RSSB – continued development of an RCF damage parameter. Report no. AEATR-ES-2004- 880 Issue 2, 2004, 74pp. London: Rail Safety and Standards Board (<http://www.rssb.co.uk>)

Ben Worley and Mark Burstow. Control Period 5 (CP5) Variable Usage Charge (VUC) guidance document, 30 April 2014a, 22 pp

Ben Worley and Mark Burstow. The variable usage charge (VUC) in CP5, Presentation January 2014b, 29 pp

K Karttunen, E Kabo, and A Ekberg. The influence of track geometry irregularities on rolling contact fatigue. Wear, 2014, vol 314, pp 78-86 [KK].

### 9.3 PREDICTION BASED METHODS

The methods presented in section 9.2 predict costs of deterioration based on experience and related empirical data. As discussed, this limits the predictive ability of the analysis and also to account for new operational conditions. This was partly addressed in the Network Rail VUC-model where numerical simulations were carried out to allow the model to distinguish between vehicles with different dynamic characteristics.

In this section, the approach with numerical simulations is taken further. Possibilities for detailed analyses of consequences of operational upgrades on track and switches & crossings are outlined. This includes a thorough outline of consequences of different operational types of upgrading, methods and modelling to estimate the effects in detail, and potential strategies to minimize the consequences.

These investigations are the last steps in the upgrade investigation chain. This does of course not imply that all previous analysis levels have to be investigated – in many cases it is very clear already at the onset that detailed investigations will be required. However, if experience based analyses as outlined in sections 9.2 have been carried out, these should have resulted in a fairly good overview of which topics that need further evaluation, and also the order of magnitude of the consequences of an upgrade.

This section sets out by identifying the consequences of increased axle loads and speeds. These upgrades will increase the actual load imposed on the track and switches & crossings, however in very different manners – a higher payload will increase the average load level, whereas an increased speed will increase the scatter in load magnitudes around an average that is not altered.

The focus is then turned towards the influence of longer trains, increased operational frequencies and an increased load gauge. These do not in themselves increase the imposed load in terms of load *per wheelset*, but will still have consequences on deterioration and maintenance needs for the track structure. As an example, an increased operational frequency will increase the deterioration *per time unit*. Longer trains, increased operational frequencies and an increased load gauge will also have other consequences that do not relate to deterioration of track and vehicles.

It should be noted that the study focuses on requirements to allow for upgrading in terms of infrastructure capabilities and (increased needs for) maintenance. Some other aspects are not explicitly included in this overview. This includes topics such as

- noise emission and ground vibration
- logistics issues
- general safety issues
- additional environmental issues

These topics were discussed briefly in section 9.1.3 and are not unimportant – they should be considered in every upgrading plan. However, the analysis of these topics is highly dependent on local

conditions. Further, the excluded topics are of general concern and should therefore not be confined to an assessment of track and switches & crossings. In general, a well-planned upgrading should be able to keep these issues at levels existing before upgrading, or even decrease them – just in the same manner as a well-planned upgrading can keep or even decrease track deterioration.

Analyses described in this section require high quality in input data, employed tools (including calibration), and staff carrying out the analyses. We are in several cases dealing with analyses that are on the engineering and research forefront. Further, errors in analysis assumptions, input data, and result evaluations may have dire consequences on the outcome since the relations are highly non-linear. Such errors run the risk of resulting in misleading conclusions and costly mistakes. Note however that even though the predictive analyses described in this section do require more input data than the experience based analyses, it is usually easier to estimate (especially the most important) parameters in the predictive models. The reason is that these typically relate to well-defined physical quantities and not aggregate measures of a more diffuse sort.

Finally, it can be noted that the predictive analyses can be used to optimise choices by adding LCC and RAMS evaluation of different operational scenarios to the analysis, see Ekberg and Paulsson (2010).

### 9.3.1 CONSEQUENCES OF HEAVIER AND/OR FASTER OPERATIONS

As mentioned above a higher payload will increase the average load level, whereas an increased speed will increase the scatter in load magnitudes around an average that is not altered. This will correspond to differences in needs for the technical performance of the track structure, different characters of the increased deterioration, and different key influencing parameters for the different phenomena.

In particular note that “heavier” in the context of this paper implies increased load per wheel (either due to an increase in the allowable axle load or that trains are loaded higher within existing load limits). The cases where loading is increased by the use of longer trains or more operations that are frequent are dealt with in subsequent sections.

In general, heavier load will – as far as track and switches & crossings are concerned – correspond to an increase in low frequency (including static) loads, whereas a higher speed will correspond mainly to an influence at higher frequencies (up to some kHz in the case of rail corrugation). This also translates e.g. to the influence of vibration and noise: For example, a higher speed shifts the main emission source from sleeper, to rail, to wheel and finally to air streams, see e.g. Thompson and Jones (2009).

Below, the influence on different components of the track – and on switches and crossings – will be discussed in detail. The different phenomena will be described, possibilities of predicting upgrading consequences will be outlined, and means of limiting the negative consequences will be proposed.

## RAILS

---

### PHENOMENA

---

For **heavier** operations, a detailed, knowledgeable and very up-to-date practical treatise is given in Leeper and Allen (2015).

For faster operations, a good first overview can be obtained from UICs information on the topic, see UIC (2017).

The phenomena resulting from axle load upgrade vary depending on operational specifics. Mechanical deterioration phenomena related to the rail (and wheel) can be ordered in a “hierarchy” roughly depending on the time to damage formation as follows:

- Plastic deformation – Plastic deformation basically occurs always in the wheel/rail interface. However, in most cases the plastic deformation decreases with time and sometimes ceases completely – so-called (elastic) shakedown. In this context, “plastic deformation” implies large-scale plastic flow that results e.g. in lipping (material roll-out on the field corner) of the railhead, heavy deformation of insulated joints etc. Such large-scale plastic deformation is typically a sign of very high dynamic loads and/or poor contact geometry.
- Wear including periodic wear – Wear is a result of high interfacial shear combined with a large relative motion (creep) between wheel and rail (see figure 9.5). Wear will modify wheel and rail profiles, which will influence contact stresses. This may result in a more conformal contact where contact stresses are more evenly distributed (so-called wear-in), which may decrease wheel and rail deterioration. However, wear may also lead to poorer steering of the vehicles, which may increase subsequent deterioration. In addition, wear may form in periodic patterns, which results in corrugation of the railhead and/or out-of-roundness of the wheel. This phenomenon will increase (vertical) dynamic loads, which is highly detrimental especially in fast operations where it may promote the formation of subsurface initiated rolling contact fatigue. Finally, wear will also remove small defects and cracks on the surface of wheels and rails, which generally is beneficial. To retain the positive effects of wear while avoiding the drawbacks, artificial wear in the form of rail grinding and wheel reprofiling is generally adopted.

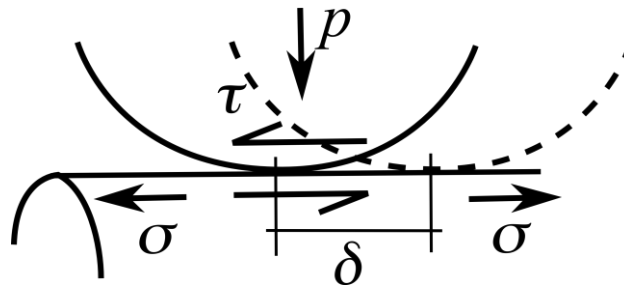

FIGURE 9.5. DEFINITION OF CONTACT PRESSURE ( $p$ ), INTERFACIAL SHEAR STRESS ( $\tau$ ) AND RELATIVE SLIDING DISTANCE,  $\delta$ , OF TWO INITIALLY ALIGNED POINTS.

- Surface initiated rolling contact fatigue – This form of rolling contact fatigue relates to the formation of surface cracks, typically as a consequence of long-term accumulation of plastic deformations (so-called ratcheting) or low-cycle fatigue damage accumulation. Once cracks are initiated they will grow as a consequence mainly of shear deformation of the crack faces and under the influence of the deformed material texture. Longer cracks may deviate to a transverse growth, which may cause rail breaks. More details on the formation and growth of surface initiated rolling contact fatigue may be obtained from Ekberg and Kabo (2005).
- Subsurface initiated rolling contact fatigue – This form of rolling contact fatigue relates to the formation of fatigue cracks below the running surface of a wheel or a rail. The crack will typically propagate below the surface until final fracture occurs either towards the surface – typically breaking off a large part of the surface material – or transversely into the wheel or rail – causing a catastrophic failure. More information can be found in Ekberg and Kabo (2005).
- Plain fatigue – Typical results of plain fatigue are foot cracks in rails and disc cracks in wheels. A special form related to high axle loads and a severely worn railhead is fatigue crack formation on the underhead radius of the railhead, see e.g. Magel et al (2015). If unattended, plain fatigue cracks may cause rail breaks. It should especially be noted that the critical size of a rail foot crack (i.e. the size of the crack that corresponds to fracture) is small (approximately a thumbnail), see e.g. Ekberg et al (2015).

In addition to the general description of the problems given above, it should be noted that a railway track consists of rail sections that are especially prone to deterioration. Such constructions include insulated joints see e.g. Sandström and Ekberg (2009) and Sandström et al (2012), welds see e.g. ch 5.6 of Ekberg and Paulsson (2010), and sections with reductions in the load carrying capacity of the rail, e.g. due to holes.

In particular, upgraded operations will affect switches & crossings. In principle, a switch & crossing construction can be considered a sharp curve with interface gaps (an actual comparison between contact forces in a sharp curve and a switch & crossing can be found in Braghin et al (2013). This will require consideration of all problems related to a sharp curve (plastic deformation, wear, rolling contact fatigue), but also additional considerations of the influence of the interface gaps. These include plastic deformation, wear and RCF of crossing components.

---

## MEANS OF PREDICTION

---

A standard way of analysing the influence of upgrades is to couple an analysis of the dynamic interaction of train and track in the upgraded state to a subsequent damage evaluation. To be able to predict likely changes in the deterioration pattern, an analysis should also be carried out for the existing operational conditions. For the train–track interaction analysis, commercial codes (Gensys, Simpack, Vampire, Nucars etc) can be employed.

The different deterioration phenomena typically require different approaches to prediction. A brief overview of options is presented below:

In the case of **plastic deformation**, there is generally a need to investigate the amount of plastic deformation and whether the plastic deformation is confined to some initial load cycles (i.e. if shakedown will occur). This typically requires finite element simulations. Further, these simulations need to feature an elastoplastic material model with non-linear kinematic hardening that has to be calibrated towards the cyclic response of the rail material. Note that the simulations need to be three-dimensional, which increases the simulation times significantly.

If the analysis of train/track interaction is carried out using commercial codes, these include modules for evaluation of **wear**. A common method of predicting wear is Archard's wear law, see Archard (1953).

$$V_{\text{wear}} = k \frac{P \times d}{H} \quad (6)$$

Here  $V_{\text{wear}}$  is the volume of wear,  $P$  is the normal force,  $d$  is the sliding distance (see Figure 9.4),  $H$  is the hardness of the material considered and  $k$  is a wear coefficient that will depend on the contacting materials, sliding speed contact pressure, etc. The Archard wear equation gives a quantitative measure of the wear volume and requires two material parameters: the hardness and the wear coefficient.

Another option is to employ the  $T\gamma$ -model, see e.g. Burstow (2004) and section 9.2.2. Here wear is related to a wear number,  $T\gamma$ , which is the product of interfacial shear force ( $T$ ) and the creepage in the wheel/rail interface ( $\gamma$ ). Wear (and RCF) is then assessed through a damage function. In essence, the damage function states that for low  $T\gamma$  magnitudes, no damage will occur. As the magnitude of  $T\gamma$  increases, rolling contact fatigue will increase up to a peak magnitude where wear will start to have an effect in reducing the apparent amount of RCF (by wearing off initiated RCF cracks). For sufficiently high  $T\gamma$  magnitudes wear will dominate completely and there will be no RCF. In addition to the operating conditions, the  $T\gamma$ -model requires calibration of the (presumed bi-linear) damage function, which requires four material parameters. For a more in-depth description, see Burstow (2004).

For **surface initiated rolling contact fatigue** (RCF) the previously mentioned  $T\gamma$  criterion can be used. It should here be noted that a low damage evaluated by the  $T\gamma$ -criterion could correspond to either a low  $T\gamma$  magnitude (implying no damage) or a very high  $T\gamma$  magnitude (implying gross wear). Note that

---

the original formulation of the  $T\gamma$ -criterion does not account for creep due to spin. An extension where this is incorporated can be found in Dirks and Enblom (2011).

Alternatively, a shakedown based approach can be taken, see e.g. Johnson (1989). Commonly, such an approach employs a shakedown map, see Figure 9.6. Here the condition in the wheel/rail interface (at any given time) is characterized by a work point (WP in Figure 9.6.) which is given by the normalized vertical load (peak contact pressure divided by the yield limit in shear) and the traction coefficient (utilized interfacial shear force divided by the normal contact force). If the work point is outside the boundary line (BC in Figure 9.6) plastic deformation will occur on the contacting surface and rolling contact fatigue cracks will initiate.

The shakedown approach was extended by Ekberg et al (2002) with the derivation of a “fatigue index” for surface initiated rolling contact fatigue. This index (which is the horizontal distance from WP to BC in Figure 9.6) can be expressed as

$$FI_{\text{surf}} = f - \frac{2\rho abk}{3P} \quad (7)$$

where the traction coefficient  $f = F_{\text{lat}}/P$  where  $F_{\text{lat}} = \sqrt{F_x^2 + F_y^2}$  and  $F_x$  and  $F_y$  are the lateral forces and  $P$  the normal contact force (positive in compression). Further,  $a$  and  $b$  are semi-axes of the hertzian contact patch, and  $k$  the yield limit in cyclic shear.



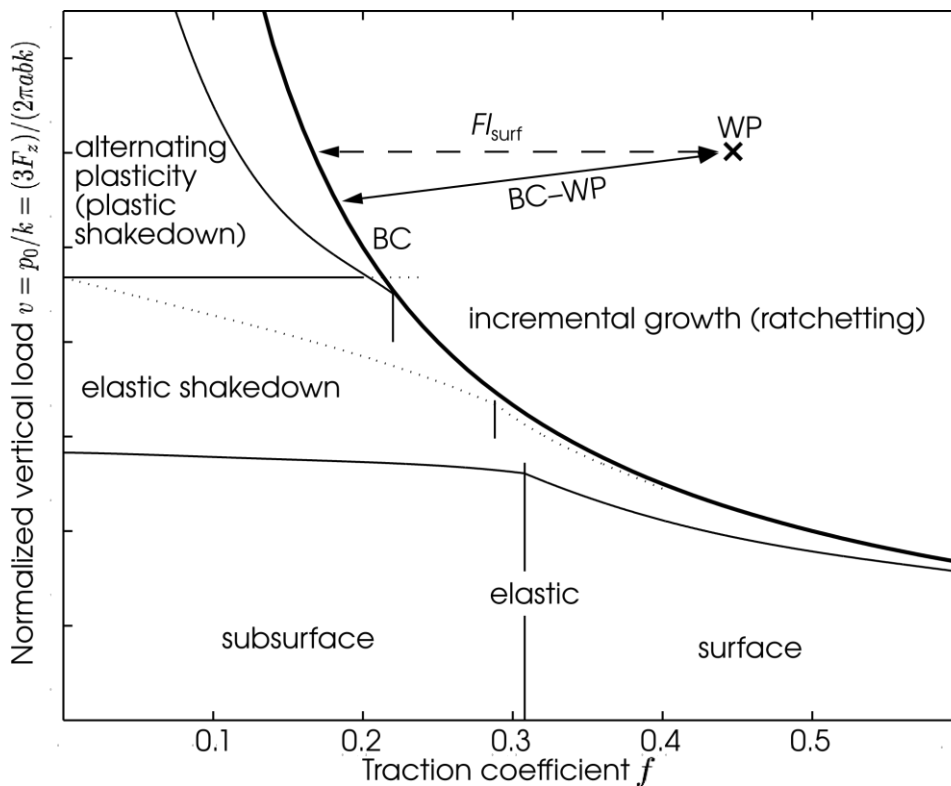

FIGURE 9.6. SHAKEDOWN MAP WITH INDICATION OF THE SURFACE FATIGUE INDEX  $FI_{SURF}$

Note that shakedown-based approaches presume hertzian contact conditions<sup>2</sup>, and full slip<sup>3</sup>. Extensions to account for full slip by adopting the local traction can be found in the literature, see Dirks and Enblom (2011). It should be noted that this is a conservative assumption, as quantified in Ekberg et al (2016).

The only material parameter in the shakedown diagram is the yield limit in cyclic shear. It should be noted that this is not really a material constant, but evolves during loading. In addition, the influence of temperature may be significant, see Ahlström et al (2016).

Note that the methods to predict surface initiated rolling contact fatigue presented here do not provide an absolute life unless the output is calibrated towards evaluated RCF lives. For the fatigue index, a tentative calibration of a Wöhler type fatigue life equation yields, see Kabo et al (2010)

<sup>2</sup> Hertzian contact conditions imply linear elastic material, a small contact area compared to body dimensions and contact radii, and smooth surface geometries on the macro and micro scale. If these presumptions are fulfilled, the resulting contact patch will be elliptic.

<sup>3</sup> Full slip implies that the interfacial friction is proportional to the normal pressure  $p$ , i.e.  $\tau = fp$  with  $f$  being the traction coefficient.

$$N_f = 1.78(FI_{surf})^{0.25} \leftrightarrow D = (FI_{surf})^4/10 \quad (8)$$

Here  $N_f$  is the fatigue life and  $D$  the fatigue damage. Note that for comparative purposes as is commonly the case in comparing different upgrading scenarios, there is less need to evaluate absolute fatigue lives.

In contrast to surface initiated rolling contact fatigue, **subsurface initiated rolling contact fatigue (RCF)** is more of a high-cycle fatigue phenomenon. In other words, it is not so much related to the global plasticity of wheel and rail, as to the local damage formation in the presence of material defects located some 2–20 mm below the wheel tread. Employing a multiaxial fatigue criterion according to Dang Van, subsurface initiated rolling contact fatigue can be considered a risk if the following inequality is fulfilled, see Ekberg et al (2002).

$$FI_{sub} = \frac{F}{4\rho ab} \left(1 + f^2\right) + c_{dv} S_{h,res} > t_{e,red} \quad (9)$$

Here  $c_{dv}$  is a material parameter (for “normal steels” a reasonable estimation is  $c_{dv} \approx 1/3$ ). Further,  $\sigma_{h,res}$  is the hydrostatic part of the residual stress. Note that employing the theoretical benefit of a compressive residual stress (i.e.  $\sigma_{h,res} < 0$ ) is likely to be non-conservative. Further,  $\tau_{e,red}$  is the reduced fatigue limit in shear, which can be estimated as

$$\tau_{e,red} \approx \tau_e (d/d_0)^{-1/6} \quad (10)$$

Here  $d$  is a “worst case defect”,  $\tau_e$  the nominal fatigue limit, and  $d_0$  the corresponding defect size (typically in the range 10  $\mu\text{m}$  to 20  $\mu\text{m}$ ).

It should be noted that subsurface initiated rolling contact fatigue are related to vertical contact stresses. This can relate to heavy haul operations. However, high magnitudes of vertical contact stresses are also induced by high-frequency dynamic forces, see e.g. Nielsen et al (2005). To evaluate the latter calls for numerical analyses see e.g. (Ekberg et al 2007), and track force measurements, see e.g. Gullers et al (2011) of train–track interaction that can incorporate high-frequency loads – typically up to about 2 kHz.

For the case of **plain fatigue** standard analysis methods of fatigue and fracture analysis are usually accurate enough. Note that plain fatigue approaches also are valid for the growth of long rolling contact fatigue cracks that have deviated into a transverse growth and can be presumed to be driven by rail bending, see Ekberg et al (2015b).

#### MEANS OF INFLUENCING

Perhaps most efficient in mitigating the consequences of heavier and faster freight operations is to decrease contact stress magnitudes. Improved steering of the vehicles, but also an improved control of braking and traction can obtain reduced interfacial shear forces. Reductions in normal contact stress magnitudes can be obtained through better control of wheel and rail profiles. In particular, the possibility of evaluating the detrimental influence of worn profiles – and thereby mitigating the most

detrimental profiles – should be noted. This relates to both hollow worn wheels, see e.g. Karttunen et al (2014), and to matching gauge corner / flange root geometries; see Karttunen et al (2015).

Further, the track geometry plays an important role. Regarding interfacial shear, the main factor is the lateral track geometry. Increased curve radii will decrease interfacial shear, but also shift the main deterioration mechanism away from wear towards RCF. Further, lateral track irregularities will have a significant influence in both increasing deterioration magnitudes locally and in introducing a more mixed mode of wear and RCF deterioration, see Karttunen et al (2012) and Karttunen et al (2014b).

Normal contact forces will influence the risk of transverse crack growth and rail breaks, in particular in cold climate. The influence of out-of-round wheels should be especially noted, see Ekberg et al (2015b). Here impact load detectors are useful in detecting out-of-round wheels for mitigating actions as noted by UIC (2014). In addition, rail defects will induce higher loads. In particular, for operations at higher speeds it is crucial to manage rail surface defects and wheel out-of-roundness to limit the dynamic loads. Note also that high traction/braking efforts seem to be a major contributing factor to the formation of so-called squats and similar RCF phenomena, cf Grassie (2011).

In the context of vertical forces, also track stiffness variations should be considered. These tend to be of higher importance the higher the loading is. Track stiffness variations concern “large-scale” transitions, e.g. in the entrance to a bridge, but also “small-scale” deviations such as hanging sleepers. In the latter case, it has been shown, see Segond & Wibeaux (2015) that there is an increased risk for railhead cracks in an interval of some four sleeper spans in both directions from a hanging sleeper. Improving transition zone characteristics may yield significant benefits, as demonstrated in Ekberg and Paulsson (2009).

Similar as for the case of interfacial shear stresses, the wheel and rail profile matching will have a profound influence on normal stress magnitudes. It should here be noted that wear and RCF patterns on operating wheels and rails provide valuable information on the actual profile matching. In combination with an analysis of seasonal trends in wheel/rail damage, root causes of increased deterioration resulting from upgraded operational conditions can usually be identified, see e.g. Ekberg et al (2014).

The influence of wheel and rail material is an important – and very complex – topic. Depending on the main mode of deterioration, different characteristics of the material will be of more importance, cf INNTRACK (2009). In the case of plastic deformation, a higher yield limit is of course beneficial. However, it is not only the initial yield limit that is of importance, but also the ability of the material to harden under cyclic loading. This fact is used to the extreme in the case of explosion hardened manganese steel crossings. As for wear, the wear resistance typically increases with increased hardness. Note however that if the hardness is obtained through an increased carbon content, the drawback may be a decreased thermal capability (i.e. a higher risk to form martensite). As for surface initiated RCF, premium grade rails have been shown to have a better resistance, see INNTRACK (2009). However, wear and RCF are interacting phenomena where small surface cracks may be worn

off. Since premium grade rails have less wear (due to its higher hardness), this effect is less on premium steels. Consequently, artificial wear in the form of controlled grinding is required for premium grade rails. Regarding subsurface initiated rolling contact fatigue, a major factor regarding material selection is the material cleanliness. As for plain fatigue, standard fatigue strength parameters (fatigue limit including influence of environmental factors, crack growth characteristics and fracture toughness) are decisive.

To control the effects of upgraded operational conditions, increased monitoring can be adopted. In D-RAIL (2014) it was shown that the most beneficial monitoring systems are axle load checkpoints, track geometry measurement systems and hot axle box detectors from an economical and safety aspect. In addition, crack detection systems and profile measurement systems are useful in controlling and limiting deterioration, and to analyze deterioration trends. In this context, it should be noted that the influence of upgraded conditions should be monitored over a longer period – typically some years. The reason is that it takes time for deterioration patterns to develop and stabilize. Further, seasonal effects may be significant.

As for switches and crossings, basically the same means of influencing exists as for rails. In addition, there are more possibilities of influencing the switch geometry and stiffness to reduce dynamic forces and contact stress magnitudes, see e.g. examples in Ekberg & Paulsson (2009). If the needs to reduce loading are significant, there are also possibilities of very efficient – but costlier – solutions such as longer switchblades and moveable frogs.

## **FASTENING SYSTEMS, SLEEPER / SLAB AND BALLAST**

---

### **PHENOMENA**

---

Increased loads on fastenings and pads may make wear and fatigue of fastenings worse. This may trigger a vicious circle in which detaching fastenings and worn out rail pads increase dynamic loads, which results in even higher deterioration etc.

In addition to increased dynamic loads, deteriorated/loose fastenings and rail pads may result in loss of track stability. The consequences may be excessive gauge with rail rollover being the extreme example. During the warm season, also the risk of track buckling owing to thermally induced compressive stresses will increase on continuously welded tracks. In cases of high braking /tractive efforts of heavy haul trains in slopes, also rotation of sleepers may occur.

As for sleeper and slab, increased loading will of course increase the risk of fatigue and fracture. At high speeds on tracks with stiff rail pads, this relates e.g. to increased dynamic loads due to out-of-round wheels and transition zones. For higher axle loads, these issues are also relevant, but in addition, the higher axle load imposes a higher nominal load. In this context, also the effect of hanging sleepers in increasing the loading should be noted. This may cause damage to nearby sleepers, and also to the

ballast due to the "pumping effect" of a hanging sleeper that gives wear of the ballast stones (which results in so-called "whitening" of the ballast).

Increased loads will also affect ballast deterioration e.g. in the form of settlements and ballast stone degradation. Note here that (if and) how an increased dynamic wheel/rail contact load is transferred to an increased loading on sleeper and ballast is complex: Generally, if the pad stiffness is soft the increased load is confined to the rail, whereas a stiffer pad will increase load transfer into sleeper/slab and ballast, see e.g. Bolmsvik and Nielsen (2014).

Regarding track settlements, it should be noted that tamping operations generally could not restore the track geometry to the original condition, see e.g. Arasteh Khouy et al (2014). In addition, locations of high settlement typically refer to a localised condition on the track, see e.g. Ekberg and Paulsson (2010). This localised condition can be either a location where loading is increased (e.g. a transition zone) or where the resistance is decreased (e.g. due to weak subsoil). Regardless, settlements are likely to reappear soon after mitigating actions if root causes for the settlement are not mitigated – a phenomenon commonly referred to as "track memory". Operations at higher speeds and/or with heavier axle loads are likely to further aggravate these problems. Consequently, known problematic zones should be charted and mitigated before upgrading. Alternatively, they may be kept under tighter inspections during the introduction of upgraded operations.

Ballast stone degradation will generally influence the internal friction of the ballast, which will decrease the ballast's deformation resistance. In addition, the increased amount of fine material may have a detrimental effect on frost resistance and drainage capability of the track.

A decrease the lateral track resistance due to decreased internal friction of the ballast will increase the risk of track buckling. In heavier operations, the risk of track buckling is also increased by the fact that curve and braking loads are higher as loads increase. Also in faster operations braking (and acceleration) loads may be higher to reduce travel times. In addition, consequences of track buckling formations are generally worse under both heavier and faster operations. For this reason, the risk of track buckling should be considered in the assessment of consequences of upgraded operations.

#### MEANS OF PREDICTION

---

Numerical simulations of train-track interaction can be carried out to evaluate the influence of increased axle loads and/or train speed on the loading of fastenings and pads. This can include assessing the influence of deteriorated fastening systems. Note however that a thorough evaluation may require high-frequency load content to be accounted for.

Regarding the risk of track buckling, the influence of loose fastenings and ballast resistance can be assessed through FE-simulations. Note however that such an analysis is complex. In particular, the issue of how to define instability needs some consideration. Parts of the issue are scheduled for investigations in the EU-project In2Rail (a lighthouse project under Shift2Rail). Note in this context that also other factors such as ballast resistance will have a crucial effect; see Kabo (2006).

As for the risk of sleeper damage, the loading of sleeper (and slab) is very dependent on the support conditions; see e.g. UIC (2014). Track stiffness measurements can be used to identify sections where the support conditions may be insufficient.

Sleepers and slab should be designed to account for the increased loading. However, a design following too conservative design criteria regarding the risk of concrete cracking in sleepers may be sub-optimal. The reason is that the sleeper then becomes very stiff and heavy, which will affect the overall dynamic behaviour of the track. A more suitable option may therefore be to design the sleeper based on a statistical analysis of the risk of sleeper damage; see Bolmsvik and Nielsen (2006).

Increased ballast settlements can be predicted from evaluated contact pressure distributions between sleepers (or slab) and ballast. An example of how numerically evaluated dynamic contact forces in a turnout can be used to predict resulting settlements is given in Li et al (2014). Note that variations in track stiffness etc. along the track will lead to differential settlements. The consequence will be irregularities in vertical track geometry that induce higher dynamic wheel–rail contact forces. These higher forces cause further track settlement and can also increase the risk of other types of damage phenomena.

#### MEANS OF INFLUENCING

---

In order to reduce overloading and have better control of operating loads, axle load checkpoints can be employed to identify vehicles inducing excessive loads and prevent these from causing excessive damage to the track. This monitoring should be supported by inspection of fastening systems and sleepers. Further, investigations track stiffness will provide information on the track status. Here Rolling Stiffness Measurement Vehicles can give an objective and well-documented reports. These can then be complemented by visual inspections where "whitening" of ballast due to hanging sleepers can be identified. In combination, these investigations will provide a good basis for decisions on which track sections that require mitigation. Since poor support will increase the loading of nearby track structure, mitigation of poorly supported sleepers/slabs should be accompanied by inspection to identify potential cracks in nearby sleepers and rail (some four sleeper spans in both directions from the hanging sleeper), and to ensure the fastening system is not damaged.

To improve the ability to withstand the increased load levels and in particular high dynamic loads, sleepers (slab) and rail pad should be designed accordingly. As noted above, a statistically based design methodology has significant benefits to this end. In addition, sleeper/slab support conditions may be improved through tamping and the use of (correctly tuned – i.e. with correct stiffness) under sleeper pads (USP), see UIC Code 713-1 Under Sleeper Pads (USP), Recommendations for Use.

In addition, there is a major potential in designing transition zones as to minimize dynamic loading. This topic is investigated in the European project In2Rail.

As for higher speed, this generally calls for more stable track support, especially at speeds corresponding to scenarios of future high-value freight operations. There are in essence two ways of achieving this:

1. Sleeper track on compacted and homogenous support where under sleeper pads or similar are employed to ensure sufficient track flexibility and load distribution.
2. Slab-track solutions of varying designs with sufficiently strong support with uniform stiffness.

Both solutions have benefits and drawbacks. These include the long-term stability of the track geometry, as well as costs and complications when the geometry eventually needs to be mitigated. Slab track solutions essentially eliminate the (admittedly low on high-quality tracks) risks of track buckling and flying ballast. Further, the risk of rail breaks is lower on slab tracks due to the decreased bending of the rail.

In both sleeper and slab tracks, the risk of hanging sleepers / poor support of track sections needs to be accounted for. This includes requirements for drainage that can handle flooding events and solutions to prevent and mitigate track settlements. Further aspects to be considered when designing the track solution include the risk of rail corrugation, noise emissions etc. as well as environmental, safety and economic consequences.

To find an optimal balance between these different factors is complex. The task is not made easier by the fact that neither the "sleeper track", nor the "slab track" is a well-defined construction: There exists a multitude of solutions, and the characteristics of the different track solutions vary significantly also within each category. Ultimately, the choice of a suitable track support for the upgraded conditions therefor comes down to a thorough analysis to establish relevant, realistic and well-defined technical requirements for the track. See also chapter 13.

#### **SWITCHES & CROSSINGS**

---

As noted above, phenomena occurring on plain track are also found in switches & crossings (S&C), often to a higher degree. There are several reasons that S&Cs are over-represented in failure statistics. Some of these are:

1. The construction imposes a stiffness transition in the track
2. Lack of cant when the wheelset enters a diverging track
3. The complicated geometry gives rise to high contact pressures due to contact point transitions, contact close to free edges, etc.
4. High loading at fairly small cross-sections, e.g. in switch-blades
5. Impact loads due to traversals of gaps
6. High frictional loads due to sharp curving in diverging mode
7. The switch contains moving parts
8. The switch interacts closely with the signalling system

The influence of these (and other) effects can be analysed using methods and tools discussed in the section "Means of prediction" above. It could be noted that the complex geometry naturally complicates such analyses, commonly requiring the use of finite element simulations. Further, there

are four modes of traversing a switch (facing/trailing move, through/diverging route). Actions that improve the characteristics in one of the modes does not necessarily benefit the other modes – it may even be that they are detrimental.

As for the items in the list above, these can be mitigated to some extent in different manners:

1. Stiffness transitions lead to high vertical (and potentially lateral) loads, which may cause settlements, rolling contact fatigue (RCF) and plastic deformations. The influence can be mitigated by designing the support structure in an appropriate manner. In this process, the correct use of rail pads, under sleeper pads (USP) and under ballast mats (UBM) is important.
2. The lack of cant can be compensated by the design of the switch, and by better steering performance of the train. Further, the resulting wear can be minimized by the use of premium rail grades.
3. High contact pressures that may cause RCF and plastic deformation can be targeted by adapted profiles. A complication is that these have to be able to handle all passing wheel profiles. In general, the result is that the profiles have to be adopted so that the majority of the wheel profiles give rise to (relatively) low contact pressures, whereas some outlier wheel profiles may cause high contact pressures, but do not cause a safety risk.
4. The loading of switch blades can cause plain fatigue and plastic deformation of the switch blades. The amount of loading can be controlled by the switch geometry. This is however a complicated issue since a late transition to the switch blade (i.e. when the switch blade cross-section is larger) has negative effects on the curving capability of the switch.
5. Impact loads may result in settlements, plastic deformations, wear and RCF can be decreased by designing profiles to allow for a smooth passage over the discontinuities in the running band, especially at the crossing. Also in this case it is a matter of compromise since the profiles also need to ensure a safe and not too severely loaded passage also of poor wheel profiles (e.g. with significant hollow wear). A further extension in reducing impact loads is the use of moving frogs. Drawback with these are the cost and that they introduce an additional moving part, which may affect the reliability.
6. The high frictional loads that can cause wear and RCF can be targeted by better curving through more track-friendly vehicles and/or a tailored gauge widening, see INNOTRACK (D3.1.5) and INNOTRACK (D3.1.6) for details. Further the use of longer switches (with more shallow curving) and lubrication are potential mitigating actions.
7. The moving parts in a switch introduces additional modes of failure as the movement can be jammed by objects (ballast stones, ice etc.), the driving and locking devices may fail etc. To minimize these risks, it is important to make the design as fail-proof and robust as possible. This also includes aspects such as a precise evaluation of allowable closure gaps. Further, there is a need for well-planned monitoring and maintenance to identify and mitigate potential problems before they cause



8. The close interaction with the signalling system means that failures in switches & crossings will be reflected in the signalling system and vice versa. Normally one branch of maintenance staff handles the signalling system, whereas switches & crossings typically is included in the track maintenance. It is therefore important to be able to locate malfunctions as precisely as possible. This also relates to the aspiration to have clear interfaces between switches & crossings and the signalling system. Note also that a similar interface exists between switches & crossings and the power supply.

In addition to the description above, it should be noted that operations in a diverging route are often the most detrimental for switches & crossings. Consequently, not only the operational frequency, but also even more the frequency of operations in a diverging route will govern the deterioration of a switch. As an example from Sweden, an increase in traffic in the diverging route of only some 2–3 million gross ton per year resulted in increases of maintenance by around 100%. This example shows that an increase of traffic in diverting track is important but the exact increase in deterioration of a specific switch will vary due to many other parameters like steering capability of the bogies.

Switches & crossings are used to give flexibility in operations and are therefore usually placed at key locations in a system. By definition, they also involve at least two tracks. As a result, the failure of switches & crossings will often cause more operational disturbances than a failure on the line.

In summary, heavier axle loads and higher speeds will essentially have a similar influence on switches & crossings as on the plain track. However, the impact and the consequences are worse for reasons discussed in this section. For this reason, a separate and more detailed investigation on the consequences of upgrading on switches & crossings is recommended. In particular, there are often some key switches & crossings in a network (e.g. at the entrance to major stations and shunting yards). To investigate these in detail and adopt strategies to mitigate detrimental effects of upgraded conditions is necessary.

### 9.3.2 CONSEQUENCES OF LONGER TRAINS

#### TRACK DETERIORATION

---

In contrast to higher axle loads or faster operations, operations with longer trains do not necessarily increase the load magnitude on individual axles; whether this is the case will depend on the train configuration as discussed below. If the loading on the individual vehicle axles is not increased, the mechanical consequences of the altered operational loading (as related to the track) are confined to the influence of the increased number of passing axles on a track section. Before a discussion on the consequences of longer trains, it is vital to understand the difference between increasing the load magnitude on (a number of) axles and increasing the number of passing axles: In general, mechanical

damage (be it rolling contact fatigue, settlements etc) can often be approximated as proportional to ( $\propto$ ) the number of load cycles (passing wheels) and to an exponential function of the load, i.e.

$$D \equiv 1/L \propto N \cdot P^m \quad (11)$$

Here  $D$  is the damage,  $L$  is the remaining operational life,  $N$  the number of load cycles (passing wheels),  $P$  the load and  $m$  an exponent, typically in the order of 3. From equation (11) it is clear that a doubling of the load per axle has far more detrimental consequences than a doubling of the number of passing axles. Naturally equation (11) is a very rough approximation – e.g. loads under a certain threshold magnitude are not considered to have any (or only a very small) influence on deterioration. Still it shows the qualitative differences between the two ways of doubling the loading.

In the case of vertical loading, a longer train generally will not influence the load on individual axles. Consequently, the influence on increased deterioration will be through the increased number of axles. Thus, the theoretical decrease in track life should be proportional to the number of axles.

A longer train generally requires higher tractive and braking efforts. If these efforts are distributed per wagon this will not increase the braking and tractive efforts per axle. For braking this might be the case if distributed tread braking is employed. However, there is a current trend towards more regenerative braking, which will concentrate the increased braking efforts on the locos. For traction, the usual scenario in freight operations is that this is provided by locos.

If locos are employed for higher traction and braking efforts, the results will be more wear and rolling contact fatigue on loco wheels. On the rail, this will typically correspond to an increased occurrence of gauge corner wear, and head checks. In the case of increased traction, there is also a growing agreement in the research community that this is a likely cause for increased squat formation.

In a scenario where increased braking and/or tractive efforts are delivered by the loco there will also be an increased requirement for sufficient friction in operations with steeper slopes and/or required stops.

There are also a number of more vehicle related issues with operations of longer trains. One such issue is the increased loading of couplings. A common way of mitigation is the use of distributed locos in the train, see e.g. Govender & Pillay (2015). An additional phenomenon that may occur is longitudinal vibrations within the train, see e.g. Muginshtein & Yabko (2015). These issues and the efficiency of mitigating actions can be investigated by numerical simulations and further assessed through field measurements e.g. of stresses in couplings.

Finally, it should be noted that there is a larger risk of derailment for longer trains. This is especially the case if unloaded (or lightly loaded) wagons are placed in the front part of the train.

## INFRASTRUCTURE NEEDS

---

Longer trains may also require modifications of the infrastructure. Such modifications include:

Meeting stations	that may need to be extended to allow the longer trains to utilise the station.
Level crossings	that may need to be modified to ensure that road signals etc. operate for a sufficiently long time. In addition, there may be needs for actions to avoid too long road closures if the long trains are operating in parallel with shorter (and faster) trains.
Signalling sections	which may need to be adjusted to account for the longer trains.
Signals	that may require repositioning e.g. so that stopped trains do not block a level crossing or intrude on the loading gauge of a nearby track at meeting stations. This also includes repositioning to ensure that slopes at a stop signal are sufficiently low also for the longer trains.

### 9.3.3 CONSEQUENCES OF INCREASED OPERATIONAL FREQUENCY

If the operational frequency is increased without any modifications to the vehicles, the increased deterioration of the track will – in theory – increase in direct proportion to the number of trains (see the elaboration on this in the previous section on longer trains). There are however still significant practical complications that will arise. In short these can be summarized as

- There will be shorter intervals (in wall-clock time) between required maintenance actions.
- There will be less time (and shorter intervals) available in track for the required maintenance actions.
- There will be less room for – and worse consequences of – unplanned events such as vehicle breakdowns.

In short, these consequences interact and together significantly complicate and increase costs for maintenance. In the extension, this requires a shift from a reactive “infrastructure approach” – where faults are dealt with as they occur – towards a pro-active “process approach” – where operations are required to continue around the clock and potential disruptions need to be handled before they interfere with operations. This requires a decrease in the need for track access, a minimization of deterioration, swifter inspections and more efficient maintenance routines. These topics are discussed in the next section.

### 9.3.4 CONSEQUENCES OF INCREASED LOAD GAUGE

Unless an increased load gauge also affects the load of the vehicles, it will not lead to any increased deterioration of the track. It will however have consequences on the track construction that need to be considered. This will be described in overview below. See also chapter 6 Tunnels.

#### WIDER LOAD GAUGE

---

Operations with a wider loading gauge require a general gauge widening on the parts of the lines to be operated with the wider gauge. Naturally this will cause logistic complications if wider gauge is allowed only on parts of a network, or even in cases where different gauges are allowed in connected countries with international operations.

As for curves the required load gauge will not only depend on the nominal gauge of the vehicles, but also of their curving characteristics, e.g. how much additional space the vehicles require to negotiate curves of different radii.

Note also the particular case of stations where the required stop point before a signal is depending on the vehicles load gauge. Consequently, upgrading to a wider gauge may require moving the hindrance pole. This will need changing in the signalling system.

Tunnels are especially complicated to upgrade to a wider gauge (unless the initial design was sufficient visionary to foresee such an upgrade). Requirements to widen a tunnel will have consequences on installations, existing reinforcements etc, and may also require additional reinforcement due to a reduced load carrying capacity of the tunnel structure.

#### HIGHER GAUGES

---

Allowing a higher gauge in a tunnel is generally easier than adopting to a wider load gauge, since the case of a higher gauge can be accomplished by increasing the depth of the tunnel through bench blasting. In general, this has much less effect on the bearing capacity of the tunnel structure than an increased width.

On the line outside of tunnels an increased height of the gauge should give no complication as long as it is within the catenary tolerances. If not, either the track section need to be lowered or the catenary heightened. In the former case, special care needs to be taken regarding culverts etc, but also regarding signalling installations in the track bed.

#### MEANS OF PREDICTION / INFLUENCING

---

Typically, consequences of an increased gauge are evaluated through (static or quasi-static) geometrical analyses. To improve the ability to account for the dynamic motions of the train, these can be complemented with multi-body simulations of train–track interaction. In special cases (e.g. tunnel entrances) also aerodynamic characteristics may affect the required geometry.

The analytical and/or numerical analyses can be complemented by track load gauge measurements from an operating vehicle and by track based vehicle load gauge measurements.

Basically, the only means of influencing the effect of a certain load gauge is through the bogie design. Through the bogie design the height and the lateral deflection of the wagon can be controlled to some extent. Note however that all wider vehicles on the line need to be mitigated if this should be an efficient approach.

### 9.3.5 REFERENCES

Johan Ahlström, Elena Kabo and Anders Ekberg, Temperature-dependent evolution of the cyclic yield stress of railway wheel steels, *Wear*, vol 366–367, pp 378–382, 2016

Iman Arastehkhoy, Håkan Schunnesson, Ulla Juntti, Arne Nissen and Per-Olof Larsson-Kråik, Evaluation of track geometry maintenance for a heavy haul railroad in Sweden: A case study, *IMechE Journal of Rail and Rapid Transit*, vol228, no 5, pp 496–503, 2014. DOI: 10.1177/0954409713482239

J F Archard, Contact and Rubbing of Flat Surface, *Journal of Applied Physics*, vol 24, no 8, pp. 981–988, 1953

Rikard Bolmsvik & Jens Nielsen, Dimensionerande böjmoment i sliprar vid 35 tons axellast (in Swedish), Research report 2006:09, Department of Applied Mechanics, Chalmers University of Technology, 97 pp, 2006

Rikard Bolmsvik & Jens Nielsen, Optimization of Railway Concrete Sleeper Design, Research report 2014:07, Department of Applied Mechanics, Chalmers University of Technology, 44 pp, 2014

Francesco Braghin, Anders Ekberg, Björn Pålsson, Dimitri Sala, Dirk Nicklisch, Elena Kabo, Paul Allen, Philip Shackleton, Tore Vernersson & Michel Pineau, D-RAIL Deliverable D3.2 – Analysis and mitigation of derailment, assessment and commercial impact, 283 pp + annex 18 pp, 2013.

M C Burstow, Whole life rail model application and development for RSSB – continued development of an RCF damage parameter, Rail Safety & Standards board, Report AEATR-ES 2004–880, Issue 2, 66 pp, 2004

Babette Dirks and Roger Enblom, Prediction model for wheel profile wear and rolling contact fatigue, *Wear*, vol 271, pp 210–217, 2011

D-RAIL, Deliverable D7.4: Industry guidelines / standard for implementation of monitoring techniques, 100 pp, 2014

Anders Ekberg, Elena Kabo and Hans Andersson, An engineering model for prediction of rolling contact fatigue of railway wheels, *Fatigue & Fracture of Engineering Materials & Structures*, vol 25, no 10, pp 899–909, 2002

Anders Ekberg and Elena Kabo, Fatigue of railway wheels and rails under rolling contact and thermal loading – an overview, *Wear*, vol 258 no 7–8, pp 1288–1300, 2005

Anders Ekberg, Elena Kabo, Jens C O Nielsen & Roger Lundén, Subsurface initiated rolling contact fatigue of railway wheels as generated by rail corrugation, *International Journal of Solids and Structures*, vol 44, pp 7975–7987, 2007

Anders Ekberg and Björn Paulsson (eds), INNOTRACK – Concluding technical report, International Union of Railways (UIC), ISBN 978-2-7461-1850-8, 288 pp, 2010

Anders Ekberg, Elena Kabo, Kalle Karttunen, Bernt Lindqvist, Roger Lundén, Thomas Nordmark, Jan Olovsson, Ove Salomonsson & Tore Vernersson, Identifying the root causes of damage on the wheels of heavy haul locomotives and its mitigation, *IMechE Journal of Rail and Rapid Transit*, vol 228, no 6, pp 663–672, 2014

Anders Ekberg, Elena Kabo, Roger Lundén and Motohide Matsui, Stress gradient effects in surface initiated rolling contact fatigue of rails and wheels, *Stress gradient effects in surface initiated rolling contact fatigue of rails and wheels*, *Wear*, vol 366–367, pp 188–193, 2016

Anders Ekberg, Elena Kabo and Jens Nielsen, Allowable wheel loads, crack sizes and inspection intervals to prevent rail breaks, *Proceedings of the 11th International Heavy Haul Association Conference (IHHA 2015) Perth, Australia*, pp 30–38, 2015b

Tamara Govender and Pragasen Devakaran Pillay, The evolution and operational impact of AC-DC wire distributed powered trains on the South African coal export line, *Proceedings of the 11th International Heavy Haul Association Conference (IHHA 2015) Perth, Australia*, pp 481–488, 2015

Stuart L. Grassie, Squats and squat-type defects in rails: the understanding to date, *IMechE Journal of Rail and Rapid Transit*, vol 226, pp 235–242, 2011

Per Gullers, Paul Dreik, Jens C O Nielsen, Anders Ekberg & Lars Andersson, Track condition analyser – detection of track irregularities based on instrumented wheelset measurements, *IMechE Journal of Rail and Rapid Transit*, vol 225, no 1, pp 1–13, 2011

INNOTRACK Deliverable D4.1.5, Definitive guidelines on the use of different rail grades, 45 pp, 2009

INNOTRACK Deliverable D3.1.5, Recommendation of, and scientific basis for, optimisation of switches & crossings – part 1, 30 pp (and 2 annexes, 12+12 pp), 2009

INNOTRACK Deliverable D3.1.6, Recommendation of, and scientific basis for, optimisation of switches & crossings – part 2, 20 pp (and 3 annexes 10+14+16 pp), 2009

K. L. Johnson, The strength of surfaces in rolling contact, *Proceedings of the Institution of Mechanical Engineers; Part C; Journal of Mechanical Engineering Science*, vol 203, pp 151–163, 1989

Elena Kabo, A numerical study of the lateral ballast resistance in railway tracks, *IMechE Journal of Rail and Rapid Transit*, vol 220, no 4, pp 425-433, 2006

Elena Kabo, Anders Ekberg, Peter Torstensson & Tore Vernersson, Rolling contact fatigue prediction for rails and comparisons to test rig results, *IMechE Journal of Rail and Rapid Transit*, vol 224, no 4, pp 303--317, 2010

Kalle Karttunen, Elena Kabo & Anders Ekberg, A numerical study of the influence of lateral geometry irregularities on mechanical deterioration of freight tracks, *IMechE Journal of Rail and Rapid Transit*, vol 226, no 6, pp 575–586, 2012

Kalle Karttunen, Elena Kabo & Anders Ekberg, Numerical assessment of the influence of worn wheel tread geometry on rail and wheel deterioration, *Wear*, vol 317, no 1–2, pp 77–91, 2014

Kalle Karttunen, Elena Kabo & Anders Ekberg, The influence of track geometry irregularities on rolling contact fatigue, *Wear*, vol 314, no 1–2, pp 78–86, 2014b

Kalle Karttunen, Elena Kabo & Anders Ekberg, Gauge corner and flange root degradation estimation from rail, wheel and track geometry, *Proceedings of the 10th International Conference on Contact Mechanics and Wear of Rail/Wheel Systems (CM2015)*, Colorado Springs, Colorado, USA, 9 pp, 2015

D Lazer, R Kennedy, G King and A Vespignani A, The Parable of Google Flu: Traps in Big Data Analysis", *Science*, vol. 343, no. 6176, pp. 1203-1205, 2014

John Leeper and Roy Allen (eds.), *Guidelines to best practices for heavy haul railway operations: Management of the wheel and rail interface*, ISBN 978-0-911382-63-1, 440 pp, 2015

Li, X., Nielsen, J. and Pålsson, B. Simulation of track settlement in railway turnouts, *Vehicle System Dynamics*, 52:sup1, pp 421–439, 2014, DOI: 10.1080/00423114.2014.904905

Eric Magel, Peter Mutton, Anders Ekberg and Ajay Kapoor, Rolling contact fatigue, wear and broken rail derailments, *Proceedings of the 10th International Conference on Contact Mechanics and Wear of Rail/Wheel Systems (CM2015)*, Colorado Springs, Colorado, USA, 11 pp, 2015.

Lev Muginshtein and Israel Yabko, Method of longitudinal dynamic forces simulation in freight trains with distributed traction, *Proceedings of the 11th International Heavy Haul Association Conference (IHHA 2015)* Perth, Australia, pp 642–646, 2015

Jens C O Nielsen, Anders Ekberg & Roger Lundén, Influence of short-pitch wheel/rail corrugation on rolling contact fatigue of railway wheels, *IMechE Journal of Rail and Rapid Transit*, vol 219, no F3, pp 177–187, 2005

Johan Sandström and Anders Ekberg, A numerical study of the mechanical deterioration of insulated rail joints, *IMechE Journal of Rail and Rapid Transit*, vol 223, no 3, pp 265–273, 2009

Johan Sandström, Elena Kabo, Arne Nissen, Fredrik Jansson and Anders Ekberg, Deterioration of insulated rail joints – a three-year field study, *Proceedings of the 9th International Conference on Contact Mechanics and Wear of Rail/Wheel Systems (CM2012)*, August 27 – 30, Chengdu, China, pp 301–308, 2012

Mallorie Segond and Quentin Wibeaux, The influence of track stiffness on rail crack occurrence, *Projet de Fin d'Études en Génie Mécanique*, Chalmers Applied Mechanics, 56 pp, 2014

David Thompson and Chris Jones, Noise and vibration from the wheel–rail interface, in *Wheel-rail interface handbook* (eds. Roger Lewis and Ulf Olofsson), Woodhead Publishing, Cambridge (UK), ISBN 978-1-84569-412-8, pp 477-509, 2009

UIC, Under Sleeper Pads (USP) – Recommendations for Use, Code 713-1, Draft version May 2014, 36 pp

UIC, High-speed library, <http://uic.org/high-speed-library> (accessed 2017-06-27)



## 9.4 MANAGEMENT OF UPGRADED TRACKS

The previous sections have mainly dealt with the issues of assessing consequences of upgrades and has selected an upgrade strategy that maximizes the cost/benefit ratio. This section deals with the issue of how to manage the upgraded track. The aim of the management is to maintain a suitable track quality that allows the required traffic to operate safely and reliably in a cost-efficient and environmentally friendly manner.

To this end, the current section sets out by discussing reasons for a proactive maintenance planning. However, such a planning requires the ability to predict deterioration rates and assess the effectiveness of the employed actions. This topic is dealt with in the section 9.4.1. As maintenance is required it should preferably be carried out as efficient as possible. Section 9.4.2 provides general principles for efficient maintenance and also an overview of some common maintenance practices. Finally, section 9.4.3 briefly investigates some possibilities in future maintenance procedures.

### 9.4.1 PROACTIVE MAINTENANCE PLANNING

As discussed above upgrading often leads to a requirement that deterioration per "unit load" needs to be decreased. Decreased deterioration can be obtained by decreasing the loading and/or increasing the strength of a component. However, this is generally complicated since

- Deterioration of track and switches & crossings is driven by complex and interacting phenomena, which all have a multitude of influencing and interacting parameters.
- Many of the involved parameters are encumbered with (often high) uncertainties.
- Designing the system to avoid deterioration completely is not realistic from technical, economical, operational perspectives.

As indicated by the last point, deterioration and related maintenance actions are inevitable. Since deterioration typically is an accelerating phenomenon it is often most cost-efficient not to let deterioration go too far before maintenance interventions. This is also supported by the fact that planned maintenance interventions are less costly than emergency interventions, and the fact that deterioration that has proceeded so far that it results in operational disturbances (and/or safety issues) is costly. In rough figures, non-planned maintenance is 3 to 5 times more expensive and cause often traffic disturbance.

Consequently, deterioration should preferably be dealt with in a "risk aware" and proactive manner. Note that this does not imply lower safety standards, but instead reflects an attempt to make safety standards more explicit and transparent. Ideally, such an approach would consist of an analysis of the current status and deterioration rates of the track. Then the most efficient mitigating actions are introduced at a time when they provide the lowest cost/benefit ratio. Note that such an analysis will result in different preventive actions to be considered profitable for different scenarios: Such preventive actions may be preventive maintenance, but also e.g. redundant systems in trains.

In a more common scenario the status of the track is estimated from some indicators and compared to limit magnitudes. The effectiveness of different maintenance actions is then estimated, and the selected actions carried out. However even in this common scenario there is a need to be able to predict how deterioration evolves over time and estimate the efficiency of different actions. This topic is dealt with in the next section.

The present guiding principle in the formulation of maintenance strategies among infrastructure managers in EU is to minimize corrective maintenance by transforming reactive actions to proactive interventions. This principle also aims at replacing existing cyclic maintenance with condition-based maintenance to a great extent. There is a need to improve the present fundamental principle for strategy formulation such that the following issues are covered:

- balancing cost, risk and technical performance
- transforming reactive maintenance to proactive
- integrating data and experience driven approaches for cyclic maintenance
- refocussing condition monitoring to prognostic and health monitoring
- adjusting inspection strategy to fit into RAMS based inspection schemes
- motivation of action steps at the strategic, tactical and operational level

These overall strategic priorities will serve as a guideline for low-level strategy to be used at the tactical and operational level where each maintenance and renewal task is addressed. This overall strategy can be cascaded from network level to maintainable item level, including manual works (small-scale such as surface welding and fastener re-tensioning) and mechanical works (large scale tasks such as grinding and tamping). In essence, an effective strategy aims to balance different maintenance actions, policies and concepts as shown in Figure 9.7. The abbreviations used in the figure are: TPM – total productive maintenance, RCM – reliability-centred maintenance, BCM – business-centred maintenance, Q&D – quick & dirty decision charts, CIBOCOF – *framework for industrial maintenance concept development* (center industrieel beleid onderhoudsontwikkelings-framework), LCC – life cycle costing, FBM – failure-based maintenance, T/UBM – time/used-based maintenance, CBM – condition-based maintenance, DOM – design-out maintenance, OBM – opportunity-based maintenance.

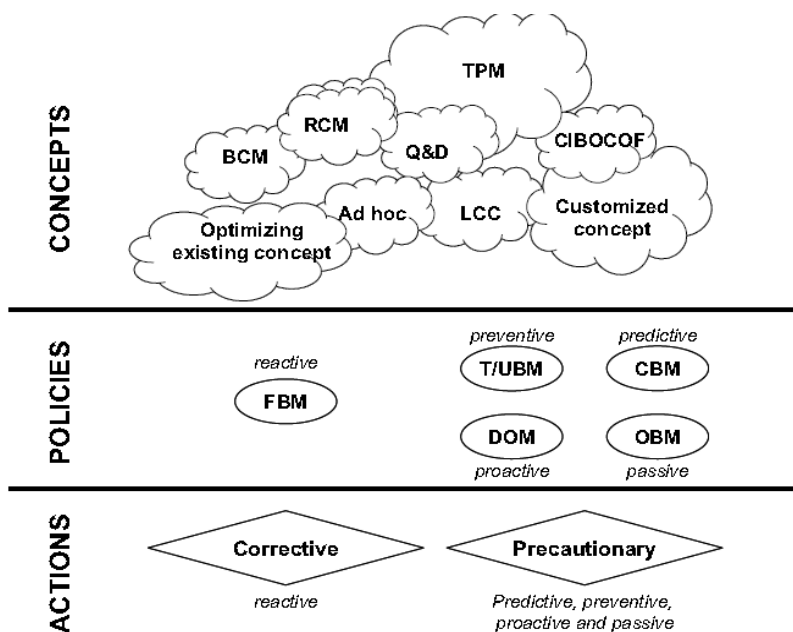

FIGURE 9.7. ACTIONS, POLICIES AND CONCEPTS IN MAINTENANCE STRATEGY, FROM PINTELON AND PARODI-HERZ (2008).

#### EFFICIENT ASSESSMENT OF TRACK STATUS

In an upgraded track, and especially if the upgrading implies increased operational frequencies, there will be less time (and shorter time slots) available in track. This calls for faster inspection and monitoring procedures to assess the current track status. It also raises the need for more swift maintenance routines, a topic that will be discussed mainly in section 9.4.2.

There are basically two ways of achieving this:

1. Focus inspections (and maintenance) on where it is most needed and where it has most effect.
2. Carry out required inspections and maintenance using less time in track.

The first item is often overlooked, but carries a major potential: Many inspection and maintenance routines are based on tradition. With development in knowledge and technology it is not certain that these are still the optimal procedures. For example, are the parameters that we measure the parameters that are most important to know? This topic is dealt with in detail in Capacity4Rail (D4.1.2). A related question is how different inspection/monitoring strategies can achieve a certain objective. This topic is dealt with in Capacity4Rail (D4.1.3).

As for less track intrusive inspection and maintenance procedures, this includes topics such as modularisation and “plug-and-play” replacements, as will be discussed in section 9.4.2. An important aspect here is the use of standardized interfaces. Here it is important to define exactly where the interfaces are (in terms of physical connections, data transfer etc) and which aspects that need to be standardized. Among other benefits, a proper definition of standardized interfaces will aid the industry in focusing on development within given frames. This should benefit both efficiency and competition.

### **IMPROVED PREDICTIVE CAPABILITIES**

---

In the section 9.3, numerical simulations were promoted as a means to validate solutions before introduction into operations. In addition, simulations have a vital role also in predicting deterioration and the risk of failure. This is critical if it should be possible to plan maintenance and inspections. It also has the additional benefit of minimizing (in the sense of indicating what and when) inspections and maintenance actions. As discussed above this reduces needs for track possessions and also lowers LCC costs.

In contrast to predicting effects of upgrades, prediction of operational deterioration can be much more supported by data collected during operations (e.g. “big data analysis”). As a first approach, such data can be analysed e.g. through regression analysis to identify trends and predict future status through extrapolation. It should be noted that it is important to continuously calibrate and validate such predictive models towards actual deterioration patterns. Further, caution must be taken if data analysis is carried out with no underlying physical model since such analyses can be imprecise and deteriorate over time, see e.g. Lazer et al (2014). To this end, the aim should be to support data based analysis with numerical simulations featuring physical models. In such an approach, the numerical simulations can be tuned from the observed behaviour. In addition to allowing extrapolations of current operational characteristics, such an approach will also provide the massive benefits of being able to analyse “what if scenarios” and to investigate likely consequences of planned changes in operations.

Possibilities and challenges in prediction naturally depend on the involved component / mode of deterioration. An overview of possibilities and challenges for a wide range of components/modes of deterioration was given in section 9.3 and references therein.

### **AVOIDING UNPLANNED MAINTENANCE AND FAILURES**

---

As mentioned above, upgraded conditions – in particular such that involve increased operational frequencies – decrease the room for, and increase consequences of unplanned disruptions. In simplistic terms, this means that “trial-and-error” is no longer an option. Solutions must therefore be validated before introduction in operations as far as possible. The means that a validation process needs to be undertaken before installation. Such a process may involve:

- Simulations – an efficient way to evaluate a number of “what if” scenarios with varying complexities.
- Scaled tests – that may provide a less expensive way to test physical phenomena.
- Test track operations – although typically limited in what can be tested (and costly) such tests provide a controlled environment that can e.g. be used to validate/calibrate simulations.
- Operations on low-frequency lines and/or operations in other networks – in some sense as close to “real life” as can be, but differences between test conditions and future operational conditions must be identified and quantified.

Costs will increase the further towards the bottom of the list you come. For this reason, and also since it allows studies of numerous alternative solutions, there is a strive towards carry out more of the investigations through numerical simulations. This shift towards virtual analysis, testing and homologation reflects what has already taken place in many other sectors. A particular challenge for the railway sector is that many simulations aim to analyse an operational life where maintenance is regularly carried out. This situation is similar to that of the aircraft industry where the mechanical design relies on regular inspections and relevant repairs. In the railway industry, the case is more complex due to the interaction of track and vehicles with large variation in characteristics, and the resulting variation in deterioration mechanisms and rates. However, many of the approaches employed in other sectors are still valid in the railway sector.

In addition to validating solutions as far as possible beforehand, there is also a need to mitigate any operational complications (especially during the “run-in” period) as fast and efficient as possible. Ideally this calls for a pre-operations risk analysis before the start of upgraded operations not only from a logistics/operational point-of-view, but also from a technical point-of-view.

#### 9.4.2 EFFICIENT MAINTENANCE

A railway track is a complex system, which comprises a number of subsystems, cf Table 9.2. The maintenance of these subsystems is a challenging issue and needs to account also for geographical and geological features, topography and climate conditions need to be accounted for, cf Jimenez-Redondo (2012). The required performance and reliability of the entire railway system depends on the performance and reliability of each of these heterogeneous subsystems. In particular, any type of fault/failure in any component might result in a system fault/failure or higher degradation rate(s) in other subsystem(s). To achieve the desired overall system performance, it is therefore necessary to account for interaction between the subsystems, not the least the interaction with operating vehicles.

As indicated in section 9.4.1, the maintenance procedure sets out with an assessment of the track status. To this end, there are manual and automated inspection methods as discussed in section 9.4.1 and in Capacity4Rail (D4.1.2) and (D4.1.3). Insufficient inspections (too long inspection intervals) may result in higher risk of accidents, lower track availability and greater maintenance cost. On the other hand, too frequent inspections can cause increased traffic disturbances and consume an unnecessary amount of resources.

Thereafter, the collected data is processed to identify faults that need to be restored either by preventive or corrective maintenance actions. Critical failures, which may cause derailments, are reported immediately to the operation control centre and the infrastructure manager.

The maintenance is then carried out at intervals (limits) that assure the required safety and reliability in an as efficient manner as possible. Note that extra or inadequate maintenance may result in higher degradation rates. As an example, too frequent tamping results in higher degradation of the ballast.

On the other hand, allowing the track quality to deteriorate to higher levels by postponing maintenance would require more than one tamping operation since the initial track quality cannot be achieved by normal tamping and may therefore also lead to higher degradation rate of the ballast, see UIC (2008).

As a general rule, maintenance strategies will differ for different operational situations. This includes all operational variables, such as type and status of track, type and status of vehicles, operational patterns etc. An effective strategy addresses cost, risk and performance factors by making optimal trade-off between them, cf Kumar et al (2008). In the presence of adequate information, simulation of possible scenarios is possible in a cyclic process that continues until a suitable balance with acceptable trade-off is reached. Some examples of application of new technologies are given in Mainline D1.4 (2014).

**TABLE 9.2 MAINTENANCE ROUTINES FOR TRACK SUBSYSTEMS, ADOPTED FROM LICHTBERGER 2005.**

<b>Track subsystems</b>	<b>Inspection and maintenance routines</b>
Rails	<ul style="list-style-type: none"> <li>• Ultrasonic / eddy current inspection</li> <li>• Welding</li> <li>• Grinding / milling</li> <li>• Joint replacement</li> <li>• Replacement</li> </ul>
Fastenings	<ul style="list-style-type: none"> <li>• Elastic pads renewal</li> <li>• Gauge correction</li> <li>• Re-tensioning</li> <li>• Replacement</li> </ul>
Sleepers – in case of ballasted track	<ul style="list-style-type: none"> <li>• Tamping</li> <li>• Replacement</li> <li>• Implementation of Under Sleeper Pads</li> </ul>
Ballast – in case of ballasted track	<ul style="list-style-type: none"> <li>• Tamping</li> <li>• Stabilising</li> <li>• Cleaning</li> <li>• Refilling</li> <li>• Wild plants removal</li> </ul>
Track formation	<ul style="list-style-type: none"> <li>• Track geometry measurements</li> <li>• Draining</li> <li>• Insertion of frost protective layer</li> <li>• Insertion of geotextile / ballast mats</li> <li>• Completing and compacting</li> <li>• Insertion of frost protective layer</li> </ul>
Slab in case of ballast-less tracks	<ul style="list-style-type: none"> <li>• Grout injection of crack</li> <li>• Adjustment of slab by injection (soil / HBL)</li> </ul>
Subsoil	<ul style="list-style-type: none"> <li>• Draining</li> <li>• Examination of defective locations</li> <li>• Soil replacement</li> <li>• Soil improvement</li> </ul>

An overview of common maintenance practices is presented in Table 9.2. As most maintenance actions relate to rails, this topic will be discussed in some detail below.

#### RAIL AND WHEEL GRADE SELECTION

The selection of wheel and steel grades is generally governed by the operational loading. In very general terms a premium grade steel shows less wear and less propensity for head check formation. In contrast, a softer rail will be more "forgiving" in that wear-in of the rail profile towards (an envelope of passing) wheel profiles is a fairly fast process. With less natural wear, premium rail grades require grinding to assure that profile matching between rail and wheel is good. The trade-off is a more stable profile as well as lower risk of head check formation and slower crack growth when these occur. Note that this implies that benefits of premium grades are generally confined to curves. Rail grade selection commonly sets out from UIC (Leaflet 721R), which considers this, and also considers cases of increased traffic, heavier axle loads, higher speeds and the introduction of new generation of rolling stock. It is partly based on the findings from the EU-project INNOTRACK (D4.1.5) and Paulsson and Ekberg (2010). Regarding (heavy) freight traffic, the topic is also discussed in the IHHA Best practice handbook, Leeper and Allen (2015).

An interesting new development in steel grades for rails and wheels is the use of bainitic steels. These generally have a very high resistance against rolling contact fatigue, but to obtain equally high wear resistance as for pearlitic steels there is a need for a strictly controlled manufacturing process, see e.g. Sawley and Kristan (20013) and Gianni et al (2009).

#### CRACK DETECTION

To detect cracks on wheels and rails, a broad range of inspection methods are employed. These include ocular inspection, ultrasonic testing, eddy-current testing and even magnetic particle inspection at special occasions.

The inspection interval is often regulated in the safety regulations of the infrastructure manager. These regulations are usually developed during – and rely on – years of practical experience. An important standard here is UIC 712 where different types of cracks are described. A change in operational conditions (fleet upgrading, altered wheel and rail profiles, increased axle loads etc.), or in maintenance strategies will have an effect on the formation and development of rolling contact fatigue cracks. Consequently, empirically decided inspection intervals may no longer be relevant.

Ultrasonic inspection of the rail is a common method to detect visible and non-visible rail head crack formation. In the case of upgraded conditions, there is often a need for faster testing to reduce operational disturbances. The detection is then carried out using ultrasonic train inspection, which can be performed as stop or non-stop inspections. Stop testing provides immediate verification of defects while non-stop testing allows for a chase vehicle to verify defects at indicated locations.

Ultrasonic testing only finds deeper cracks. There is thus a need for complimentary testing, e.g. based on eddy-current methods, to identify cracks closer to the surface. These surface cracks may also interfere with the ultrasonic testing so that deeper crack may stay undetected. Other challenges of ultrasonic testing include the difficulty to test high manganese steel crossings, see e.g. Lundberg et al (2011).

## **GRINDING**

---

As discussed in section 9.3.1, deterioration of the railhead can take the form of plastic deformation, wear, or contact fatigue (or a combination of these). This results in an altered contact geometry, crack formation etc, which need to be mitigated through grinding. In addition, grinding can also be employed to decrease surface roughness (corrugation) and thereby limit resulting rolling noise and dynamic wheel–rail contact forces, see Nielsen and Ekberg (2011). Note that also new rails should to be ground in order to remove any rolling mill scale and adopt the profile to operational conditions.

To increase the lifespan of the rails and to decrease the life cycle costs preventive rail grinding is nowadays frequently used. Rail grinding was investigated in INNTRACK resulting in four deliverables (D4.5.1, D4.5.2, D4.5.3, D4.5.4) and the basis for a UIC/UNIFE Technical recommendation (D4.5.5). This work represented the latest findings at the time. However, it did not include neither High Speed Grinding (HSG) nor milling.

In contrast to conventional grinding where commonly 48 or 64 grinding stones are used, HSG requires a special high-speed grinder that runs at a speed of approximately 80km/h. This higher speed is the major advantage of HSG as the grinding trains operates like a “normal” train without causing major disturbance to operational traffic. Especially at lines with passenger trains at day and freight trains at night this is a major benefit. The drawback is that the grinder only removes a small amount of material due to the high speed. Therefore, re-profiling of the rail or grinding in curves with high side wear is not suitable for HSG. In these cases, conventional grinding is necessary.

One strategy to maximise the benefit is to set out with a virtually defect free rail surface, which could be achieved by conventional grinding. HSG is then used to remove cracks and others defects at an early stage. In this sense, HSG is employed to act as a controlled “natural” wear.

Depending on the selected grinding strategy and boundary conditions (traffic, rail steel, track layout, routing), the amount of grinding activities per year necessary to maintain the rail surface free of defects can be decided. In addition, there may be a need for additional grinding to limit roughness levels, in particular at track sections where it is important to limit noise emissions.

The grinding strategy can then be gradually refined. Note however that if the traffic situation is altered it is important re-examine the grinding strategy.

If the employed grinding strategy is not able to remove surface defects, these may grow. In the case of periodic wear, the result may be severe corrugation that may cause significant problems. In the case



of rolling contact fatigue, the cracks may propagate into the rail head and cause a complete rail break. Although a single rail break is usually not a major safety risk, a cluster of rail head cracks (which typically occur in curves) may result in multiple rail breaks that may cause severe derailments.

#### WHEEL RE-PROFILING

---

As detailed in section 9.3, wheels with inadequate tread geometries may cause excessive deterioration of both the wheels themselves and the track structure on which they operate. Such wheels need to be reprofiled so that their tread geometry is restored. Since wheel reprofiling is costly and consumes part of the operational life of the wheel, appropriate tolerances for allowable wheel geometries are highly important.

Further, wheel reprofiling is a process that needs to be scheduled. Accurate predictions of wheel status are therefore important to enable more cost-effective maintenance operation. Such a prediction can be experience based and/or employ predictive analyses as outlined in section 9.3. In particular, methods to quantify the detrimental influence of a wheel profile as detailed in Karttunen et al (2014) and Karttunen et al (2016) can help in prioritising wheel maintenance.

Categorisation of wheel defects have been compiled in defect catalogues, see e.g. Deuce (2007). In terms of normal wheel wear, it is important to know whether to expect predominantly flange wear or hollow wear as the influence on wheel life is significant. Flange wear relates to poor curving characteristics and often require significant material removal to restore the profile. Hollow worn wheels and wheels with uniform tread wear typically require less material removal. However, if the wear process progresses too far, these wheels may cause additional problems such as crack formation on wheels and rails. If cracks form and are allowed to propagate, they may cause a need for major reprofiling.

From a general maintenance perspective, the wheel geometry is currently defined by the flange thickness, slope and height. The former two are basically safety measures, whereas the third is an indirect measure of tread wear. Although wheel reprofiling is generally carried out towards limit values related to these measures, they provide only a rough picture of the overall wheel geometry and how this geometry affects the rail. More refined methods are being developed that employ the entire wheel profile geometry to quantify its impact on further imposing deterioration, see Karttunen et al (2014).

Here it should be noticed that most vehicles have restrictions on wheel diameter differences between wheels on the same axle or in the same bogie. For this reason, it is not unusual that most reprofiling occurs as a secondary consequence of the need to reprofile one damaged wheel. To limit the amount of material removal in reprofiling is therefore of high importance since it affects not only one, but several wheels.

## LUBRICATION

---

As discussed in sections 9.3 the formation of wear and rolling contact fatigue (and also noise generation) relate to wheel/rail friction. Friction management, e.g. using gauge lubrication, top-of-rail friction modifiers, and/or wheel flange lubrication is a possibility to decrease these forms of deterioration.

A large amount of Top of Rail (TOR) related research regarding friction at the wheel/rail interface and corresponding energy savings have been produced. Often these investigations use simplified small-scale lab apparatus to estimate friction properties. One example of these types of research contributors regarding friction and energy savings is presented in Raman et al (2013). In general, the study reports potential energy savings (up to 30 % of power reductions) if the friction can be kept at an optimum. This is however most likely unrealistic. More important is the (relatively limited) investigations of the impact of friction modifiers on rolling contact fatigue. Here Reiff (2007) reported reduced crack formation and grinding requirements with the use of friction modifiers in heavy haul applications, as compared to a control zone. Further, Eadie et al (2008) investigated the effect of friction modifiers on short pitch corrugation generation in curves in a field study. Torstensson and Nielsen (2015) have also demonstrated the effectiveness of combatting the formation of rutting corrugation in curves.

The influence on lubrication on crack formation and growth is complex: On the one hand, lubrication decreases wheel–rail friction, which decreases the propensity for crack formation. On the other hand, lubrication may aid crack propagation, see e.g. Tyfour et al (1996) and Bogdanski et al (2005). The detrimental effect of lubrication on rolling contact fatigue crack growth has been attributed to a lubricating effect of crack faces (which tends to promote shear mode growth), and to hydropressurization (which tends to promote normal stress driven growth of the crack). There is still no general consensus as to the dominating effect.

The influence of lubrication on crack propagation depends on its ability to penetrate the crack, see Fletcher et al (2007). This ability should depend on the viscosity of the lubricant. In this context, it may also be noted that care should be taken when selecting a suitable lubricator in order to assure that it is environmental friendly at the same time as it needs to be efficient also in harsh climate conditions.

In summary, lubrication may have detrimental effects on longer braking distances and rolling contact fatigue crack growth. However, if properly used it will decrease wear and rolling contact fatigue crack formation and also noise emissions.

## WELDING

---

Welding is the common way to join rails on high-performance tracks. There are different methods to weld rails, among which flash-butt and thermite welding are most common. The topic has been studied e.g. in the European research project INNOTRACK (D4.6.1, D4.6.2, D4.6.3, D4.6.4, D4.6.5, D4.6.6). This

work currently continues with work in the European projects In2Rail (repair welding) and WRIST (friction welding and high-pressure thermite welding).

In short, the main challenge with welding is to join the rail ends while causing as little disturbances to the rail as possible. This includes obtaining a narrow heat-affected zone, minimizing hardness variations over the weld, and achieving a uniform wear resistance. Failure of obtaining any of these objectives may result in excessive dynamic loads. In addition, a weld will normally introduce a detrimental state of residual stress. Together with material defects that may be results of poor weld quality this will also increase the propensity for crack formation.

### 9.4.3 DEVELOPMENT IN MAINTENANCE PROCEDURES

#### AUTOMATION OF MAINTENANCE

The operational maintenance of track can be more or less automated by the adoption of machines that are autonomous to a lower or higher degree. Difficulties and suitability for automation varies between applications: In the case of switch failure occurrences (e.g. track geometry failure over short length of track, surface welding and switches), manual maintenance, supported by small machines, is usually performed and (so far) beneficial. However, for other maintenance actions (e.g. tamping, ballast stabilizing and grinding) maintenance actions are becoming increasingly more automated.

Not only is the operational maintenance starting to become automated. As data harvesting increases, so does the potential for automated maintenance decisions and prioritization. This requires relevant measurement data that can be stored in a fairly compact form and translated to maintenance decisions. An example of this trend is the automated categorization of wheel profiles based on their impact on wear and rolling contact fatigue formation, see Karttunen et al (2014). This automated procedure parameterizes (e.g. laser) measured wheel profiles, which allows for compact storage. The parameterized data are then evaluated with respect to their impact on wear and rolling contact fatigue formation using meta-models. Such an automated analysis can for example be used to derive a prioritization list for wheel reprofiling.

By means of the new automated measurement system and development of decision support tools, future track degradation and potential failures should to an even greater extent be possible to predict in advance. This provides a time horizon for planning logistics and for allocating a maintenance possession time prior to failure.

Optimized maintenance processes generally reduce the required maintenance possession time. Consequently, the capacity of the European rail network can be increased to allow increased freight traffic. To monitor and guide this development, Key Performance Indicators (KPIs) and categories of performance killers/drivers for RAMS and LCC need to be identified, developed and transformed into

a railway user environment for adaption and implementation. This topic is discussed in AUTOMAIN (D4.2).

#### INNOVATIVE MAINTENANCE CONCEPTS

An effective guideline for best maintenance practice requires the application of innovative maintenance concepts to enhance the performance of railways. Rule of the thumb and conventional maintenance concepts are almost reaching their performance threshold due to emerging technologies and operational demands, boundary conditions and defined targets. Innovative decision structures or logic for exploring maintenance and renewal tasks and scenarios before taking decisions are therefore required for managing a high performing railway infrastructure. These concepts include:

**Streamlined reliability centred maintenance:** This involves the adaptation of a reliability centred maintenance approach for a linear infrastructure with long life span such as railways. This concept includes additional features that will overcome the complexity of the conventional approach and also support the use of computerized maintenance management systems to achieve a more efficient maintenance decision structure and logic.

**e-maintenance concepts:** The concept of applying Information and Communication Technologies (ICT) as an enabler in maintenance management process is a promising future solution of infrastructure maintenance. This concept uses ICT “e-technologies” for such as e-monitoring, e-diagnosis, e-prognosis to support maintenance decision and actions, see Karim (2008). This concept is the required solution to support implementation of real time, remote, prognostic and collaborative maintenance.

**RAMS and LCC based maintenance concepts:** The integration of LCC and RAMS concepts as philosophies in maintenance practices will help to fine-tune maintenance decisions. These concepts will help to improve infrastructure up-time, maintain infrastructure integrity, and assure safe working conditions and environment, with limited maintenance budgets. Seamless integration of these two concepts as provided in European standards (EN50126) and (EN60300-3-11) will provide perspectives that will guide effective maintenance practices.

**RAM4S:** Traditional practice of RAMS (Reliability, Availability, Maintainability and Safety) is a characteristic of a system’s long-term operation and can be characterized as a qualitative and quantitative indicator of system performance and technical integrity for the fulfilment of Quality of Service (QoS) requirements in a life cycle perspective. These RAMS characteristics for a railway system can describe the confidence with which it can guarantee the achievement of a defined level of rail traffic in a given time. As an extension, cost effective, environmentally friendly and sustainable design, deployment and use of railway infrastructure can be realized through development and application of integrated RAM4S (Reliability, Availability, Maintainability, Safety, Security, Sustainability and Supportability) models, technologies and methodologies. Safety, security and availability are inter-linked in the sense that a weakness in either, or mismanagement of conflicts between safety, security and availability requirements, may prevent the achievement of a dependable and robust system. In

this effort, focus should be on developing and adapting methodologies, technologies and models to decide on the RAM4S requirements of railway infrastructure based on the capacity requirements and

1. identify bottlenecks to achieve required QoS levels for infrastructure, e.g. regarding capacity
2. link these factors to technical functions and items of the infrastructure and thereby define critical functions and items to be addressed
3. link the critical functions and items to system requirements
4. define engineering configurations of the technical system that meet RAM4S requirements
5. define a system-integrated asset life cycle management model that supports maintenance decisions based on RAM4S principles

**Bridge concept:** Another innovative and emerging trend in maintenance is the idea of “cherry picking” or building bridges between useful aspects of commonly used maintenance concepts and philosophies. These could for example be value-driven maintenance (VDM), risk-based centered maintenance (RBCM), business centered maintenance (BCM), lean-RCM and constrain-based RCM, see Pintelon and Parodi-Herzin (2008) and Figure 9.6 where the “cherry-picking” approach is represented by the CIBOCOF concept.

## 9.5 REFERENCES

AUTOMAIN Deliverable D4.2, Optimised maintenance activities like, grinding, tamping and other maintenance processes, (2013)

Bogdanski S., Lewicki P. and Szymaniak M., Experimental and theoretical investigation of the phenomenon of filling the RCF crack with liquid, *Wear*, v 258, (2005), 1280–1287

Capacity4Rail Deliverable D4.1.2, Monitoring-based deterioration prediction, 131 pp, 2016

Capacity4Rail Deliverable D4.1.3, Strategies for data collection and analysis, in preparation

Deuce R. Wheel tread damage – an elementary guide. Report no. 100115000, 2007, 38pp. Netphen, Germany: Bombardier Transportation GmbH.

EN50126. Railway applications - The specification and demonstration of Reliability, Availability, Maintainability and Safety (RAMS). European Standard 1999

EN60300-3-11. Dependability Management Part 3-11: Application guide- Reliability Centered Maintenance. European Standard 1999

Eadie D. T., Elvidge D., Oldknow K., Stock R., Pointner P., Kalousek J and Klauser P., The effect of top of rail friction modifier on wear and rolling contact fatigue: Full scale rail-wheel test rig evaluation, analysis and modeling, *Wear* 265 (2008) 1222–1230

Ekberg A. and Paulsson B (eds), INNOTRACK – Concluding technical report, International Union of Railways (UIC), ISBN 978-2-7461-1850-8, 288 pp, 2010

Fletcher D. I., Hyde P and Kapoor A, Investigating fluid penetration of rolling contact fatigue cracks in rails using a newly developed full-scale test facility, Proceedings of the Institution of Mechanical Engineers, Part F: Journal of Rail and Rapid Transit, v 221, (2007), pp. 35–44.

Gianni A., Ghidini A., Karlsson T. and Ekberg A., Bainitic steel grade for solid wheels: metallurgical, mechanical, and in-service testing, IMechE Journal of Rail and Rapid Transit, vol 223, no 2, pp 163-171, 2009

INNTRACK Deliverable D4.1.5, Definitive guidelines on the use of different rail grades, 45 pp, 2009

INNTRACK Deliverable D4.5.1, Overview of existing rail grinding strategies and new and optimised approaches for Europe, 8 pp (and 3 annexes, spreadsheet + 23 + 7 pp), 2007

INNTRACK Deliverable D4.5.2, Target profiles, 10 pp, 2008

INNTRACK Deliverable D4.5.3, Fields of improvement in grinding practices as input for LCC evaluations, 16 pp (and 2 annexes, 11+7 pp), 2009

INNTRACK Deliverable D4.5.4, Friction management methods, 13 pp, 2009

INNTRACK Deliverable D4.5.5, Guidelines for management of rail grinding, 20 pp, 2010

INNTRACK Deliverable D4.6.1, The influence of the working procedures on the formation and shape of the HAZ of flash butt and aluminothermic welds in rails, 19 pp, 2008

INNTRACK Deliverable D4.6.2, Report on the influence of the working procedures and post treatment on static and dynamic fatigue behaviour of aluminothermic welds, 13 pp, 2008

INNTRACK Deliverable D4.6.3/D4.6.4, Analysis of equipment design and optimisation of parameters for gas pressure welding, 32 pp (and 3 annexes 1+2+5 pp), 2008

INNTRACK Deliverable D4.6.5, Gas pressure welding – Quality of test welds, 15 pp (and 3 annexes 8+23+10 pp), 2009

INNTRACK Deliverable D4.6.6, Weld performance in track test – supervision of weld properties in terms of rail profile, rail straightness and neutral temperature (preliminary report), 42 pp, 2009

Jimenez-Redondo N., et al, Automated and cost-effective maintenance for railway (ACEM-Rail), Procedia – Social and Behavioral Sciences 48, 1058–1067, 2012.

Karim R. A service-oriented approach to e-maintenance of complex technical systems. PhD-thesis Luleå University of Technology, 2008, 91 pp.

Karttunen K., Kaho E. and Ekberg A., Numerical assessment of the influence of worn wheel tread geometry on rail and wheel deterioration, Wear, vol 317, no 1–2, pp 77–91, 2014

Karttunen K., Kaho E. and Ekberg A, Estimation of gauge corner and flange root degradation from rail, wheel and track geometries, *Wear*, vol 366–367, pp 294–302, 2016

Kumar S, Espling U, Kumar U. Holistic procedure for rail maintenance in Sweden. *Proc Inst Mech Eng Pt F: J Rail Rapid Transit* 2008; 222(4):331-344.

Leeper J. and Allen R. (Eds), *Guidelines to best practices for heavy haul railway operations: management of the wheel and rail interface*, Simmons-Boardman books Inc, 428 pp, Omaha, NE, USA, 2015

Lichtberger B., *Track compendium: Formation, Permanent Way, Maintenance, Economics*, Eurailpress, 98 pp, 2005.

Lundberg, J., Bohlin, A., Syk, M., Blindfold tests on manganese crossing in railway application, *International Journal of System Assurance Engineering and Management*, Vol 73, 2011

MAINLINE D1.4. Guideline for application of new technologies to extend the life of elderly rail infrastructure. Deliverable D1.4, 129 pp, 2014. [www.mainline-project.eu](http://www.mainline-project.eu)

Nielsen J. C. O. and Ekberg A., Acceptance criterion for rail roughness level spectrum based on assessment of rolling contact fatigue and rolling noise, *Wear*, vol 271, no 1–2, pp 319–327, 2011

Pintelon L. and Parodi-Herzin A., *Maintenance: An Evolutionary Perspective*, in Murthy DNP, Kobbacy KAH. *Complex system maintenance handbook*. London: Springer; 2008.

Raman D., Chattopadhyay G., Spirigian M. and Sajjad M., Research methodology for evaluation of top of rail friction management in Australian Heavy Haul Networks, *Proceedings from 10 th International Heavy Haul Conference 2013*, New Delhi, India.

Reiff R., Top of rail friction control on rail surface performance and grinding, *TTCI Technology Digest TD-07-039* (2007)

Sawley, K., and Kristan J. Development of Bainitic Rail Steels with Potential Resistance to Rolling Contact Fatigue, *Fatigue & Fracture of Engineering Materials & Structures*, vol. 26, (2003), pp. 1019-1029.

Torstensson, P. and Nielsen, J. (2015) Rail corrugation growth on curves – measurements, modelling and mitigation, in *Notes on Numerical Fluid Mechanics and Multidisciplinary Design*, vol 126 (2015), pp. 659–666

Tyfour W. R., Beynon J. H. and Kapoor A., Deterioration of rolling contact fatigue life of pearlitic rail steel due to dry–wet rolling sliding contact, *Wear* v 197, (1996), 255–265.

UIC, *Best practice guide for optimum track geometry durability*, Paris, France: ETF - Railway Technical Publications, 2008.

UIC 721 R (2013): Recommendation for use of rail steel grades. UIC Code 721 R, 2013, International Union of Railways, Paris



## 10. Energy supply

---

Energy supply is an important factor when upgrading to a new traffic situations. This could imply an increase demand for power: examples on this is heavier and longer trains. However it could also imply energy saving means, such as implementation of the necessary infrastructure to allow for regenerative braking.

The costs for upgrading and replacement of electrical power supply system can be significant. As an example, in the upgrading of the Heavy Haul line Malmbanan (the Iron Oreline in northern Sweden), the cost for upgrading the power supply system was 25% or about 42 k€/km track. However, this high cost was due to replacement the electrical power supply system that was not directly related to the upgrading, but the ageing of the system.

In contrast, there are other examples of track upgrading where the cost of upgrading the energy supply system have been very small since the existing power supply system had some overcapacity.

The experience from upgrading is that upgrading of the energy supply system is very dependent on the local situations. The upgrading also relies fairly heavily on local experience including characteristics of the existing energy supply system. For this reason, upgrading of the energy supply system will not be further described.

## 11. Signalling

---

Upgrading of lines to enhanced freight capabilities may pose very different challenges on the signalling system. In general, the needs for enhanced signalling systems depends on the status of the existing system and the demands of the new traffic situations.

If we consider different upgrading scenarios, heavier and longer trains may require altered signalling distances due to longer breaking distances. Increased loading gauges in terms of wider vehicles may require a move of signals and hindrance poles in switches, which may be costly. More frequent operations may require the introduction of an improved signalling system that increases the capacity.

The general experience from upgrading is that demands on the signalling system are very dependent on the local situations. They will therefore not be further discussed in this text.

## 12. Stations

---

The number and layout of stations, in particular in single line traffic, have an important impact on how the upgraded traffic situation can be handled. In particular, the introduction of longer trains will require longer stations, and wider trains will require a move of signals and hindrance poles.

As an example, upgrading of the Iron Ore line in Sweden for increased axleload, increased speed, longer trains and reduced electrical consumption, resulted in a costs for station upgrading of 14% of the total costs. The cost was especially high in mountainous terrain. The share of the cost can be compared with the costs for replacing and reinforcement of bridges, which was 10%.

The experience from this and other upgrading actions is that stations usually are an important cost factor when upgrading. However, the required actions and related costs are very dependent on the local situation.

## 13. New upgrading concepts for superstructures

A large part of freight line upgrading relates to the local strengthening of weak spots. Examples of this are when substructure quality varies locally with spots containing organic clay, reinforcement of transition zones, and improvements of sections passing culverts.

An alternative way to solve these problematic locations is to use innovative slab track concepts, as proposed in Capacity4Rail WP1.1. This work was carried out in collaborative workshops, which ended up in two alternatives—one RAMS-oriented and one LCC-oriented slab track concept.

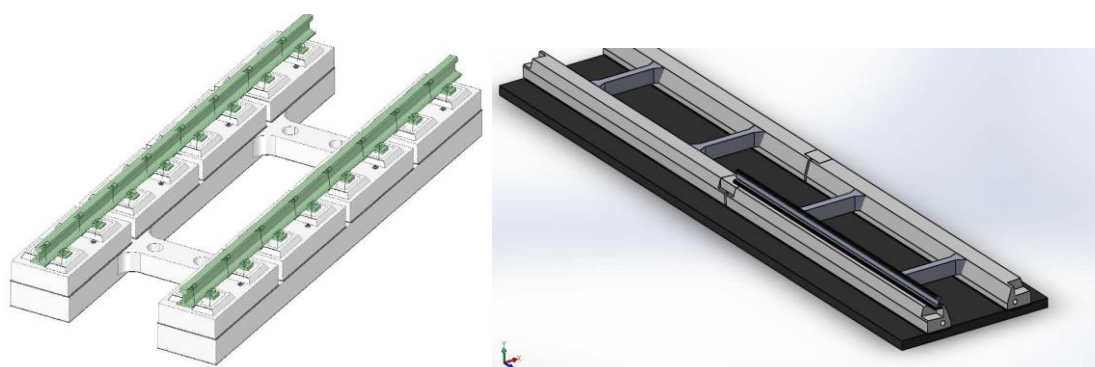

FIGURE 13.1: 3MB MODULAR SLAB TRACK SYSTEM (LEFT) AND L-TRACK MODULAR SLAB TRACK SYSTEM (RIGHT). FROM CAPACITY4RAIL WP1.1. (ALL REPORTS IN THIS WP)

The development of these slab track concepts was based on design requirements and methodology as follows:

- Environmental requirements:
  - Noise and vibrations absorbers to be included
  - Use of 2nd life materials (recycled or waste)
- Construction requirements:
  - Few stages of construction
  - Fast construction and assembly
  - Modularity
  - Easy transportation of prefabricated elements
  - Easy fitting to alignment
- Maintenance requirements:
  - Low maintenance
  - Simple replacement of components
  - Well-defined procedures for repairing unforeseeable damage
- Cost requirements:
  - Low construction cost
  - Low maintenance cost (less than ½ of ballast systems)
  - Long life cycles ( $\geq 60$  years)

Some considerations have to be made when upgrading with the Capacity4Rail slab proposals or other innovative solutions. These are:

- Demands on substructure
  - Stiffness variations—for example transition zones and poor substructure
  - Resulting load on the substructure
  - Asphalt is used in one the concept. Is this a suitable option? This is important since some previous investigations dealing with use of asphalt have not been positive to the use of asphalt. Further, asphalt has its own production process that carries an environmental footprint.
  - Load of substructures — which may have positive or negative effects.
- Production methods that can be carried out during a reasonable timeslot
  - Partly wayside production methods, which is a way to reduce traffic disturbance
  - Step-by-step construction, which is an important question for upgrading an existing line with traffic. The work has to be carried out in timeslots with intermediate traffic.
- Geometry and needed construction height, where the proposed track systems may –like several non-ballasted track systems– have solved special need/needs
- Costs compared with a ballasted track
  - Installation
  - Maintenance costs

Eventually, the selection of an innovative track system solution will be down to detailed cost/benefit and risk-analyses. Here it is essential to have a very clear understanding of the targets with the upgrading and how different aims should be ranked towards each other and towards increased costs (in a broad sense).

## 14. Conclusions

---

The introductory chapters provide background and objectives to clarify why the report is written and what knowledge it will supply.

The following chapter on general infrastructure issues describes different traffic demands and the influence on the track structure. The chapter investigates the important question of when the influence of dynamic loads exceeds the influence of static loads. The latter case can be handled by a fairly straightforward strengthening, whereas the former case will lead to gradual deterioration of the structure that has to be managed. The chapter also discusses how different operational situations influence the different types of structures in the track.

Chapter 4 focuses on substructure conditions. Here, section 4.1 deals with assessment of substructure conditions in order to identify current state and needs for possible improvement. Several techniques including rolling stiffness measurements and various geophysical geomechanical methods can provide an extensive knowledge regarding the substructure condition. However, there is a need to select the proper method(s) for the investigation at hand. Further, the interpretation and comparison of results obtained by different measurement techniques is critical for the recommendation of suitable repair and/or reinforcement solutions for the railway substructure.

In section 4.2 existing methods for subgrade improvement are presented. The selection of a proper method for the situation at hand includes factors such as the allowance of traffic during the repair, the type of soil suitable for the technique, the effectiveness in increasing each stability/strength aspect and the experience of the use of this particular technique. All explored improvement methods are assessed against these criteria.

Section 4.3 deals with ground vibrations. Some key results on reducing ground borne vibrations from the concluded EU-project RIVAS are presented. These include reductions in the generation of vibrations where wheel flats or switch sources are the main noise generators. For vehicles, it is noted that especially the unsprung mass is important. Several methods for track based mitigations and transmission reductions have been investigated in the project. Some results were briefly introduced and references to additional information – in particular to guidelines from the RIVAS project – were given.

Chapter 5 deals with bridges. Here the highest impact comes from increased loads in terms of axle loads and loads per unit length. Longer trains and increased train weights have some impact whereas higher speeds on freight trains has less impact, and increased loading gauges usually have no impact. For culverts the greatest impacts are usually the same as for bridges. For tunnels the highest influence of upgrading comes from increased loading gauges which may require an increased tunnel area. For tunnels, other changes usually have no impact. For common retaining walls the traffic situation has little or no impact.

Differences in safety concepts between codes for new and for existing structures are outlined. Many of the uncertainties that are present when building a new structure and that require a high safety factor, can be resolved when you are dealing with an existing structure, where actual loads, geometry and material properties can be determined with a high accuracy.

An assessment of existing structures as a preparation for upgrading is recommended to be carried out in three phases: Initial, Intermediate and Enhanced. The Initial phase may include a site visit, study of documentation and rough calculations. The Intermediate phase may include material investigations, detailed calculations and/or analyses, and further inspections and monitoring. The Enhanced phase usually consists of refined calculations and analyses that include statistical modelling and reliability based assessments, laboratory examinations and/or field-testing and economic decision analysis. A good assessment is often the most cost-effective way to upgrade a structure. Examples are given on how assessments indicating a high hidden capacity have been confirmed by full-scale tests to failure.

For different kinds of bridges, specific areas for upgrading/repair are indicated. Examples are also given on methods to use. These include refined calculations, increased cross sections of the bridge structure, change of system for static load distribution, external pre-stressing and the use of externally bonded fibre reinforced polymers (FRP).

For tunnels different cross sections and typical loading gauges are presented, as well as possibilities for working in tunnels with rail services in operation. Examples are also given on the conditions in countries like Germany, Austria, Switzerland, Sweden and the U.S.

For culverts different types of damage and malfunctions are described and examples are given on measures that can be taken. For retaining walls a few examples are given on how they can be constructed.

In chapter 9 (track and switches & crossings) consequences of upgraded operational conditions are investigated. It is concluded that many upgrading scenarios tend to increase the track deterioration and that this deterioration needs to be addressed and mitigated. An overview of different deterioration phenomena and descriptions of potential consequences of different types of upgrading are presented.

A two-level approach to successively refined investigations is then outlined and exemplified. The first level is an Experience based methods. In this stage, effects of the intended upgrading are assessed with rather simple models based on experience that provide an overview and rough estimations of resulting deterioration rates. The second level consists of Prediction based analyses. Here consequences of upgraded conditions in terms of increased deterioration are predicted in advance. This allows for a proactive approach where mitigating solutions may be employed and their efficiency estimated through simulations. An outline of potential analyses that to varying degrees of detail predict the influence of different track components are outlined. It can be noted that the current use of numerical simulations to evaluate consequences of upgrading on track deterioration are much less

utilised than e.g. for evaluating consequences of upgrading on bridges. This results in unnecessary complications and costs.

Also upgrading consequences that do not mainly involve increased deterioration are investigated. In particular, the case of increased operational frequencies is discussed and it is demonstrated how such an upgrade increases the need for high-precision monitoring, prediction and maintenance.

The report continues with three chapters that contain brief discussions on the influence of upgrading on energy supply, signalling and stations. In general, all of these areas require decision—and lead to consequences—that are very dependent on local conditions. For this reason, the discussions are kept brief and just highlight the essentials.

Finally, the possibility to employ novel track solutions to improve conditions at especially sensitive track sections is discussed. This topic is also discussed more in detail in other parts of the Capacity4Rail project.